



United States
Environmental Protection
Agency

Office of Water
Mail Code 4304T

EPA 822-R-16-003
May 2016

Health Effects Support Document for Perfluorooctanoic Acid (PFOA)

**Health Effects Support Document
for
Perfluorooctanoic Acid (PFOA)**

U.S. Environmental Protection Agency
Office of Water (4304T)
Health and Ecological Criteria Division
Washington, DC 20460

EPA Document Number: 822-R-16-003
May 2016

BACKGROUND

The Safe Drinking Water Act (SDWA), as amended in 1996, requires the Administrator of the U.S. Environmental Protection Agency (EPA) to periodically publish a list of unregulated chemical contaminants known or anticipated to occur in public water systems and that may require regulation under SDWA. The SDWA also requires the Agency to make regulatory determinations on at least five contaminants on the Contaminant Candidate List (CCL) every 5 years. For each contaminant on the CCL, before EPA makes a regulatory determination, the Agency needs to obtain sufficient data to conduct analyses on the extent to which the contaminant occurs and the risk it poses to populations via drinking water. Ultimately, this information will assist the Agency in determining the most appropriate course of action in relation to the contaminant (e.g., developing a regulation to control it in drinking water, developing guidance, or deciding not to regulate it).

The PFOA health assessment was initiated by the Office of Water, Office of Science and Technology in 2009. The draft *Health Effects Support Document for Perfluorooctanoic Acid (PFOA)* was completed in 2013 and released for public comment in February 2014. An external peer-review panel meeting was held on August 21 and 22, 2014. The final document reflects input from the panel as well as public comments received on the draft document. Both the peer-reviewed draft and this document include only the sections of a health effects support document (HESD) that cover the toxicokinetics and health effects of PFOA. If a decision is made to regulate the contaminant, this document will be expanded.

One of the challenges inherent in conducting this assessment was the wealth of experimental data published before and during its development. This section provides a synopsis of the approach used in identifying and selecting the publications reflected in the final assessment.

Data were identified through the following:

- Monthly/bimonthly literature searches conducted by EPA library staff (2009–2015) and New Jersey Department of Environmental Protection library staff (2012–2015).
- Papers identified by EPA internal and external peer reviewers.
- Papers identified through public comments on the draft assessments.
- Papers submitted to EPA by the public.

In mid-2013, the EPA library searches were expanded to cover all members of the perfluoroalkane carboxylate family (C4 through C12). Appendix A describes the literature search strategy used by the libraries. Through the literature search, documents were identified for retrieval, review, and inclusion in the HESD using the following criteria:

- The study examines a toxicity endpoint or population not examined by studies already included in the draft document.
- Aspects of the study design such as the size of the population exposed or quantification approach make it superior to key studies already included in the draft document.
- The data contribute substantially to the weight of evidence for any of the toxicity endpoints covered by the draft document.
- Elements of the study design merit its inclusion in the draft document based on its contribution to the mode of action (MoA) or the quantification approach.

- The study elucidates the MoA for any toxicity endpoint or toxicokinetic property associated with PFOA exposure.
- The effects observed differ from those in other studies with comparable protocols.

In addition to each publication being evaluated against the criteria above, the relevance of the study to drinking water exposures and to the U.S. population also were considered.

The studies included in the final draft were determined to provide the most current and comprehensive description of the toxicological properties of PFOA and the risk it poses to humans exposed to it in their drinking water. Appendix B summarizes the studies evaluated for inclusion in the HESD following the August 2014 peer review and identifies those selected for inclusion in the final assessment. Appendix B includes epidemiology data that provide a high-level summary of the outcomes across the studies evaluated.

Development of the hazard identification and dose-response assessment for PFOA has followed the general guidelines for risk assessment forth by the National Research Council (1983) and EPA's *Framework for Human Health Risk Assessment to Inform Decision Making* (USEPA 2014a). Other EPA guidelines used in the development of this assessment include the following:

- *Guidelines for the Health Risk Assessment of Chemical Mixtures* (USEPA 1986a)
- *Guidelines for Mutagenicity Risk Assessment* (USEPA 1986b)
- *Recommendations for and Documentation of Biological Values for Use in Risk Assessment* (USEPA 1988)
- *Guidelines for Developmental Toxicity Risk Assessment* (USEPA 1991)
- *Interim Policy for Particle Size and Limit Concentration Issues in Inhalation Toxicity Studies* (USEPA 1994a)
- *Methods for Derivation of Inhalation Reference Concentrations and Application of Inhalation Dosimetry* (USEPA 1994b)
- *Use of the Benchmark Dose Approach in Health Risk Assessment* (USEPA, 1995)
- *Guidelines for Reproductive Toxicity Risk Assessment* (USEPA 1996)
- *Guidelines for Neurotoxicity Risk Assessment* (USEPA 1998)
- *Science Policy Council Handbook: Peer Review (2nd edition)* (USEPA 2000a)
- *Supplemental Guidance for Conducting Health Risk Assessment of Chemical Mixtures* (USEPA 2000b)
- *A Review of the Reference Dose and Reference Concentration Processes* (USEPA 2002a)
- *Guidelines for Carcinogen Risk Assessment* (USEPA 2005a)
- *Supplemental Guidance for Assessing Susceptibility from Early-Life Exposure to Carcinogens* (USEPA 2005b)
- *Science Policy Council Handbook: Peer Review (3rd edition)* (USEPA 2006a)
- *A Framework for Assessing Health Risks of Environmental Exposures to Children* (USEPA 2006b)
- *Exposure Factors Handbook* (USEPA 2011)
- *Benchmark Dose Technical Guidance Document* (USEPA 2012)
- *Child-Specific Exposure Scenarios Examples* (USEPA 2014b)

AUTHORS

Joyce Morrissey Donohue, Ph.D. (Chemical Manager)
Office of Water
U.S. Environmental Protection Agency, Washington, DC

Tina Moore Duke, M.S. (previously with Office of Water, U.S. Environmental Protection Agency)

John Wambaugh, Ph.D.
Office of Research and Development
U.S. Environmental Protection Agency, Research Triangle Park, NC

The following contractors supported the development of this document:

Jennifer Rayner, Ph.D., D.A.B.T.
Environmental Sciences Division
Oak Ridge National Laboratory, Oak Ridge, TN

Carol S. Wood, Ph.D., D.A.B.T.
Environmental Sciences Division
Oak Ridge National Laboratory, Oak Ridge, TN

This document was prepared under the U.S. EPA Contract No. DW-8992342701, Work Assignment No. 2011-001 with Oak Ridge National Laboratory. The Lead U.S. EPA Scientist is Joyce Morrissey Donohue, Ph.D., Health and Ecological Criteria Division, Office of Science and Technology, Office of Water.

The Oak Ridge National Laboratory is managed and operated by UT-Battelle, LLC., for the U.S. Department of Energy under Contract No. DE-AC05-00OR22725.

Contributors and Reviewers

Internal Contributors and Reviewers

Office of Water, U.S. Environmental Protection Agency
Elizabeth Doyle, Ph.D. (retired)
Edward Hackett

Office of Research and Development, U.S. Environmental Protection Agency
Glinda Cooper, Ph.D.
Barbara Glenn, Ph.D.
Erin Hines, Ph.D.
Christopher Lau, Ph.D.
Matthew Lorber, Ph.D.
Jaqueline Moya
Linda Phillips, Ph.D.
Paul White, Ph.D.
Michael Wright, Sc.D.

Office of Chemical Safety and Pollution Prevention, U.S. Environmental Protection Agency
E. Laurence Libelo
Andrea Pfehales-Hutchens, Ph.D.
Tracy Williamson
David Lai, Ph.D. (retired)
Jennifer Seed, Ph.D. (retired)

Office of Childrens Health Protection, U.S. Environmental Protection Agency
Gregory Miller

Office of Land and Emergency Management, U.S. Environmental Protection Agency

External Reviewers

James Bruckner, Ph.D.
Department of Pharmacology and Toxicology
University of Georgia, Athens, GA

Deborah Cory-Slechta, Ph.D.
Department of Environmental Medicine
University of Rochester Medical Center, Rochester, NY

Jamie DeWitt, Ph.D.
Pharmacology and Toxicology
East Carolina University, Greenville, NC

Jeffrey Fisher, Ph.D.
Biochemical Toxicology, NCTR
U.S. Food & Drug Administration, Jefferson, AK

William Hayton, Ph.D.
College of Pharmacy (Emeritus)
The Ohio State University, Columbus, OH

Matthew Longnecker, M.D., Sc.D.
Biomarker-based Epidemiology Group
National Institute of Environmental Health Sciences, Research Triangle Park, NC

Angela Slitt, Ph.D.
Biomedical and Pharmaceutical Sciences
University of Rhode Island, Kingston, RI

CONTENTS

BACKGROUND	iii
ABBREVIATIONS AND ACRONYMS	xiv
EXECUTIVE SUMMARY	ES-1
1 IDENTITY: CHEMICAL AND PHYSICAL PROPERTIES.....	1-1
2 TOXICOKINETICS.....	2-1
2.1 Absorption.....	2-1
2.1.1 Oral Exposure	2-2
2.1.2 Inhalation Exposure	2-2
2.1.3 Dermal Exposure	2-3
2.2 Distribution	2-3
2.2.1 Oral Exposure	2-7
2.3 Metabolism	2-23
2.4 Excretion.....	2-23
2.5 Animal Studies.....	2-24
2.5.1 Mechanistic Studies of Renal Excretion	2-28
2.6 Toxicokinetic Considerations	2-34
2.6.1 PK Models	2-34
2.6.2 Half-Life Data.....	2-46
2.6.3 Volume of Distribution Data	2-51
2.6.4 Toxicokinetic Summary.....	2-51
3 HAZARD IDENTIFICATION	3-1
3.1 Human Studies.....	3-1
3.1.1 Noncancer	3-3
3.1.1.1 Serum Lipids and Cardiovascular Diseases	3-3
3.1.1.2 Cardiovascular Diseases	3-13
3.1.1.3 Liver Enzymes and Liver Disease	3-13
3.1.1.4 Biomarkers of Kidney Function and Kidney Disease.....	3-18
3.1.1.5 Immunotoxicity.....	3-22
3.1.1.6 Thyroid Effects	3-26
3.1.1.7 Diabetes and Related Endpoints	3-35
3.1.1.8 Reproductive and Developmental Endpoints.....	3-37
3.1.1.9 Steroid Hormones	3-47
3.1.1.10 Neurodevelopment.....	3-48
3.1.1.11 Postnatal Development	3-51
3.1.1.12 Summary and Conclusions from the Human Epidemiology Studies.....	3-52
3.1.2 Cancer	3-55
3.1.2.1 Summary and Conclusions from the Human Cancer Epidemiology Studies ..	3-60
3.2 Animal Studies.....	3-60
3.2.1 Acute Toxicity	3-61
3.2.2 Short-Term Studies	3-62

3.2.3	Subchronic Studies.....	3-74
3.2.4	Neurotoxicity	3-77
3.2.5	Developmental/Reproductive Toxicity.....	3-79
3.2.6	Prenatal Development.....	3-84
3.2.7	Mammary Gland Development and Other Specialized Developmental Studies ...	3-89
3.2.8	Chronic Toxicity.....	3-102
3.2.9	Carcinogenicity.....	3-106
3.3	Other Key Data	3-110
3.3.1	Mutagenicity and Genotoxicity.....	3-110
3.3.2	Immunotoxicity.....	3-112
3.3.3	Hormone Disruption	3-124
3.3.4	Physiological or Mechanistic Studies	3-129
3.3.5	Structure-Activity Relationship	3-139
3.4	Hazard Characterization.....	3-140
3.4.1	Synthesis and Evaluation of Major Noncancer Effects	3-140
3.4.2	Synthesis and Evaluation of Carcinogenic Effects	3-150
3.4.3	Mode of Action and Implications in Cancer Assessment.....	3-152
3.4.4	Weight of Evidence Evaluation for Carcinogenicity	3-158
3.4.5	Potentially Sensitive Populations.....	3-159
4	DOSE-RESPONSE ASSESSMENT.....	4-1
4.1	Dose-Response for Noncancer Effects	4-1
4.1.1	RfD Determination.....	4-1
4.1.1.1	PK Model approach	4-8
4.1.1.2	RfD Quantification.....	4-14
4.1.2	RfD Selection.....	4-16
4.1.3	RfC Determination.....	4-17
4.2	Dose-Response for Cancer Effects	4-18
5	REFERENCES	5-1
	Appendix A: Literature Search Strategy Developing the Search	A-1
	Appendix B: Studies Evaluated Since August 2014.....	B-1
	Appendix C: Multistage Model for Leydig Cell Tumors	C-1

TABLES

Table 1-1. Chemical and Physical Properties of PFOA.....	1-3
Table 2-1. Protein Binding in Rat, Human, and Monkey Plasma.....	2-4
Table 2-2. Dissociation Constants (K_d) of Binding Between PFOA and Albumin.....	2-4
Table 2-3. Percent (%) Binding of PFOA to Human Plasma Protein Fractions.....	2-6
Table 2-4. Tissue Distribution of PFOA in Wistar Rats After 28 Days of Treatment	2-9
Table 2-5. Distribution of PFOA in Male Sprague-Dawley Rats After Oral Exposure Dose.....	2-10
Table 2-6. Distribution of PFOA in Female Sprague-Dawley Rats after Oral Exposure Dose.....	2-11
Table 2-7. PFOA Concentrations in Wild-type and PPAR α -null Mice ($\mu\text{g/mL}$).....	2-12
Table 2-8. Plasma PFOA Concentrations ($\mu\text{g/ml}$) in Postweaning Sprague-Dawley Rats	2-14
Table 2-9. Plasma PFOA Concentrations in Male Rats.....	2-14
Table 2-10. Plasma PFOA Concentrations in Female Rats	2-15
Table 2-11. Maternal Plasma PFOA Levels ($\mu\text{g/ml}$) in Rats During Gestation and Lactation	2-17
Table 2-12. Placenta, Amniotic Fluid, and Embryo/Fetus PFOA Concentrations in Rats ($\mu\text{g/ml}$).....	2-17
Table 2-13. Fetus/Pup PFOA Concentration ($\mu\text{g/ml}$) in Rats During Gestation and Lactation	2-18
Table 2-14. PFOA Levels ($\mu\text{g/ml}$) in Rats Maternal Milk During Lactation.....	2-18
Table 2-15. PFOA Levels (ng/ml) in Mice During Gestation and Lactation in Selected Fluids and Tissues	2-19
Table 2-16. Female Offspring PFOA Levels (ng/ml) in Mice After GD 1-17 Exposure.....	2-20
Table 2-17. Female Offspring Serum PFOA Levels (ng/ml) in Mice After GD 10-17 Exposure.....	2-21
Table 2-18. Serum PFOA Levels (ng/ml) in Mice Over Three Generations.....	2-21
Table 2-19. Urine PFOA Concentrations in Male and Female Rats.....	2-25
Table 2-20. Cumulative Percent ^{14}C -PFOA Excreted in Urine and Feces by Rats	2-26
Table 2-21. Cumulative Percent ^{14}C -PFOA Excreted in Urine and Feces	2-27
Table 2-22. Kinetic Parameters of Perfluorinated Carboxylate Transport by OAT1, OAT3, and OATP1a1	2-33
Table 2-23. Plasma and Urine PFOA Concentration 24-hr After Treatment with 30 mg/kg PFOA.....	2-34
Table 2-24. Model Parameters for 1 and 10 mg/kg Single Doses of PFOA to CD1 Mice.....	2-37
Table 2-25. Pharmacokinetic Parameters from Wambaugh et al. (2013) Meta-Analysis of Literature Data.....	2-46

Table 2-26. PK Parameters in Male Rats Following Administration of PFOA.....	2-50
Table 2-27. PK Parameters in Female Rats Following Administration of PFOA	2-50
Table 3-1. Summary of PFOA Occupational Exposure Studies of PFOA and Serum Lipids.....	3-7
Table 3-2. Summary of High-Exposure Community Studies of PFOA and Serum Lipids	3-9
Table 3-3. Summary of General Population Epidemiology Studies of PFOA with Serum Lipids.....	3-12
Table 3-4. Summary of Epidemiology Studies of PFOA and Liver Enzymes	3-14
Table 3-5. Summary of Epidemiology Studies of PFOA and Measures of Kidney Function.....	3-18
Table 3-6. Summary of Epidemiology Studies of PFOA and Immune Suppression (Vaccine Response).....	3-23
Table 3-7. Summary of Epidemiology Studies of PFOA and Thyroid Effects in Adults	3-27
Table 3-8. Summary of Epidemiology Studies of PFOA and Thyroid Effects in Special Populations	3-29
Table 3-9. Summary of Epidemiology Studies of PFOA and Pregnancy-Induced Hypertension or Preeclampsia.....	3-39
Table 3-10. Summary of Epidemiology Studies of PFOA and Birth Weight	3-41
Table 3-11. Summary of Epidemiology Studies of PFOA and Pubertal Development.....	3-45
Table 3-12. Summary of PFOA Epidemiology Studies of Kidney and Testicular Cancer	3-56
Table 3-13. Comparison of PPAR- α Related Effects in Rats for PFOA, DEHP, and Fenofibrate after a 3-day Exposure	3-62
Table 3-14. Hepatic Effects of Rats Exposed to PFOA.....	3-65
Table 3-15. Hepatic Effects in PFOA-Treated Mice	3-68
Table 3-16. Mouse Hepatocyte Ultrastructure After PFOA or Wythe 14,643 Treatment.....	3-69
Table 3-17. Relative Response of hPPAR α , mPPAR α , and PPAR α -null Mice to PFOA.....	3-70
Table 3-18. Liver Effects in Male Rats.....	3-76
Table 3-19. Organ Weight Data from F0 Male Rats	3-80
Table 3-20. Organ Weight Data from F1 Male Rats	3-82
Table 3-21. Studies of Pregnant CD-1 Mice Following Administration of PFOA	3-90
Table 3-22. Mammary Gland Measurements at PND 21 from Female Offspring of Dams Treated GD 10–17	3-95
Table 3-23. Dosing Regimens Used in the Multigeneration Study of CD-1 Mice.....	3-96
Table 3-24. Mammary Gland Scores from Three Generations of CD-1 Female Mice	3-97
Table 3-25. Liver Weight Data in Monkeys Administered PFOA for 6 Months	3-103
Table 3-26. Subcellular Liver Enzyme Activities and Liver PFOA Concentrations.....	3-104

Table 3-27. Clinical Chemistry Values from Male Rats Given PFOA for 2 Years.....	3-105
Table 3-28. Incidence of Nonneoplastic Lesions in Rats Given PFOA for 2 Years	3-106
Table 3-29. Incidence of Ovarian Stromal Hyperplasia and Adenoma in Rats.....	3-107
Table 3-30. Mammary Gland Tumor Incidence Comparison.....	3-108
Table 3-31. Liver Tumors in Three Strains of Mice at 18 Months with Exposure to PFOA Only during Gestation and Lactation	3-109
Table 3-32. Genotoxicity of PFOA <i>In Vitro</i>	3-111
Table 3-33. Selected Clinical Chemistry Parameters in Mice Treated with PFOA for 5 Days.....	3-118
Table 3-34. Selected Clinical Chemistry Parameters in Mice Treated with PFOA for 10 Days.....	3-119
Table 3-35. Impact of PFOA on Splenic and Thymic Lymphocyte Populations	3-120
Table 3-36. Estimated EC ₅₀ Values	3-126
Table 3-37. Data Collection for Female Mice Gestationally Exposed to PFOA.....	3-127
Table 3-38. mRNA Expression of Hepatic PPAR α and Related Genes.....	3-132
Table 3-39. Activation of Mouse and Human PPAR by PFOA	3-135
Table 4-1. NOAEL/LOAEL Data for Oral Subchronic and Chronic Studies of PFOA.....	4-3
Table 4-2. Shorter-term and Developmental Oral Exposure Studies	4-5
Table 4-3. Predicted Final Serum Concentration and Time-Integrated Serum Concentration (AUC) for Studies in Rats.....	4-9
Table 4-4. Predicted Final Serum Concentration and Time-Integrated Serum Concentration (AUC) for Studies in Mice.....	4-10
Table 4-5. Predicted Final Serum Concentration and Time-Integrated Serum (AUC) in Studies of Monkeys.....	4-10
Table 4-6. Average Serum Concentrations Derived from the AUC and the Duration of Dosing.....	4-11
Table 4-7. Comparison of Average Serum Concentration and Steady-State Concentration....	4-12
Table 4-8. HEDs Derived from the Modeled Animal Average Serum Values	4-13
Table 4-9. The Impact of Quantification Approach on the RfD Outcomes for the HEDs from the PK Model Average Serum Values.....	4-15
Table 4-10. Summary of Tumor Data from Animal Studies	4-19
Table 4-11. Multistage Cancer Model Dose Prediction Results for a 4% Increase in LCT Incidence.....	4-21
Table B-1. PFOS Epi Papers—Post Peer Review (Retrieved and Reviewed)	B-1
Table B-2. PFOA Post Peer Review Animal Toxicity Studies.....	B-3
Table B-3. Toxicokinetics: Post Peer Review	B-5
Table B-4. Association between Serum PFOA and Serum Lipids and Uric Acid	B-6

Table B-5. Association of Serum PFOA and Biochemical and Hematological Measures	B-8
Table B-6. Association between PFOA level and prevalence of thyroid disease and thyroid hormone levels	B-9
Table B-7. Association between Serum PFOA and Markers of Immunotoxicity	B-11
Table B-8. Association between Serum PFOA and Reproductive and Developmental Outcomes	B-12

FIGURES

Figure 1-1. Chemical Structures of PFOA and APFO.....	1-1
Figure 1-2. PFOA Anti-Conformer.....	1-1
Figure 1-3. PFOA Lowest Energy Conformer.....	1-2
Figure 2-1. PFOA Binding Sites on HSA.....	2-5
Figure 2-2. Localization of Transport Proteins.....	2-29
Figure 2-3. Schematic for a Physiologically Motivated Renal Resorptions PK Model.	2-35
Figure 2-4. Physiologically Motivated Pharmacokinetic Model Schematic for PFOA- Exposed Rats	2-36
Figure 2-5. Schematic for One-Compartment Model.	2-37
Figure 2-6. PK Model of Gestation and Lactation in Mice	2-39
Figure 2-7. Structure of the PFOA PBPK Model in Monkeys and Humans	2-40
Figure 2-8. Structure of the PBPK Model for PFOA in the Adult Sprague-Dawley Rat	2-42
Figure 2-9. PBPK Model Structure for Simulating PFOA and PFOS Exposure During Pregnancy in Humans (Maternal, Left; Fetal, Right).....	2-43
Figure 3-1. PPAR α Agonist MoA for Liver Tumors.....	3-154
Figure 4-1. BMD Model Results for LCTs (Butenhoff et al. 2012).....	4-21

ABBREVIATIONS AND ACRONYMS

8-OH-dG	8-hydroxydeoxyguanosine
Acot1	acyl-CoA thioesterase (human)
Acox	acyl-CoA oxidase
ADHD	attention deficit hyperactivity disorder
ADX	adrenalectomized
AIC	Akaike's Information Criterion
ALP	alkaline phosphatase
ALT	alanine aminotransferase
ANOVA	analysis of variance
APFO	ammonium perfluorooctanoate
Areg	amphiregulin
AST	aspartate aminotransferase
ATP	adenosine triphosphate
AUC	area under the plasma concentration time curve
AUC _{INF}	area under the plasma concentration time curve, extrapolated to infinity
AUC _{INF/D}	area under the plasma concentration time curve, extrapolated to infinity, normalized to dose
BAX	BCL2-associated X protein
BMD	benchmark dose
BMDL	lower 95 th percentile confidence bound on benchmark dose
BMDS	Benchmark Dose Software
BMI	body mass index
BrdU	Bromodeoxyuridine (5-bromo-2-deoxyuridine)
BSA	bovine serum albumin
BSEP	bile salt export pump
BSP	sulfobromophthalein
BUN	blood urea nitrogen
bw	body weight
C	Celsius
C _{max}	peak plasma concentration at the first intestinal absorption loci
CaMKII	calcium/calmodulin-dependent protein kinase II
CAR	constitutive androstane receptor
CAT	carnitine acyltransferase
CCK	cholecystokinin
CCL	Contaminant Candidate List
CCL 3	Contaminant Candidate List 3
CFSE	6-carboxyfluorescein succinimidyl ester
ChAT	choline acetyltransferase
CHO	Chinese hamster ovary
CI	confidence interval
CL	clearance
Cl _p	plasma clearance
CL _R	renal clearance
CoA	coenzyme A
ConA	concanavalinA
COPD	chronic obstructive pulmonary disease
CORT	corticosterone

Cox II	cytochrome c oxidase subunit II
Cox IV	cytochrome c oxidase subunit IV
CPT	carnitine palmitoyltransferase
CrI	Charles River Laboratory
CSF	cancer slope factor
Cte	acyl-CoA thioesterase (rat)
CYP4A10	cytochrome P450 4a10
d	day
DCDQ	Developmental Coordination Disorder Questionnaire
Ddit3	DNA damage inducible transcript
DEHP	di(2-ethylhexyl) phthalate
DHT	5 α -dihydroxy-testosterone
dL	deciliter
DMSO	dimethyl sulfoxide
DNA	deoxyribonucleic acid
DR	dose rate
DTH	delayed-type hypersensitivity
DWI	drinking water intake
E2	17- β estradiol
E3S	estrone-3-sulfate
EC ₅₀	half maximal effective concentration
ECF	electrochemical fluorination
eGFR	estimated glomerular filtration rate
EGFR	epidermal growth factor receptor
EPA	U.S. Environmental Protection Agency
ER	endoplasmic reticulum
ER α	estrogen receptor α
Err α	estrogen-related receptor α
FID	flame ionization detector
FSH	follicle-stimulating hormone
FT4	free thyroxine
FXR	farnesoid receptor
g	gram
GAP-43	growth-associated protein-43
GD	gestation day
GEE	generalized estimating equation
GFR	glomerular filtration rate
GGT	gamma-glutamyl transpeptidase
GJIC	gap junction intercellular communication
GlyT	glycogen trophoblast cell
GnRH	gonadotropin releasing hormone
GSD	geometric standard deviation
GST	glutathione-S-transferase
hCG	human chorionic gonadotropin
HDL	high-density lipoprotein
HED	human equivalent dose
HEK	human embryonic kidney
HESD	health effects support document
HET	heterozygous

HFD	high-fat diet
HGF α	hepatocyte growth factor
HL-60	human promyelocytic leukemia cell line
HMG-CoA	3-hydroxy-3-methylglutaryl coenzyme A
HPLC/MS	High-performance liquid chromatography mass spectrometry
HPLC/MS/MS	High-performance liquid chromatography tandem mass spectrometry
HR	hazard ratio
HRBC	horse red blood cells
HSA	human serum albumin
HSD17 β 1	hydroxysteroid 17 β dehydrogenase 1
HSD3 β 1	hydroxysteroid 3 β dehydrogenase 1
IC ₅₀	half-maximal inhibiting concentration
ICR	imprinting control region
IDL	intermediate density lipoprotein
IgE	immunoglobulin E
IGF-I	insulin like growth factor I
IgM	immunoglobulin M
IHD	ischemic heart disease
IL-6	interleukin 6
INUENDO	Biopersistent Organochlorines in Diet and Human Fertility study
IQR	interquartile range
IRR	incidence rate ratio
IU	international unit
IV	intravenous
K _a	adsorption rate constant
K _d	dissociation constant
K _e	elimination rate constant
kg	kilogram
K _m	substrate concentration at which the initial reaction rate is half maximal
K _{oc}	organic carbon water partitioning coefficient
K _t	affinity constant
L	liter
L-FABP	liver fatty acid binding protein
LC ₅₀	lethal concentration for 50% of animals
LCT	Leydig cell tumor
LD	lactation day
LD ₅₀	lethal dose for 50% of animals
LDH	lactic dehydrogenase
LDL	low-density lipoprotein
LH	luteinizing hormone
LHWA	Little Hocking Water Association
LLOQ	lower limit of quantification
LOAEL	lowest observed adverse effect level
LOD	limit of detection
LOQ	limit of quantitation
LPS	lipopolysaccharide
m	meter
MCAD	medium chain acyl-CoA dehydrogenase
MDA	malondialdehyde

Mdr2	multidrug resistance protein 2
µg	microgram
mg	milligram
min	minute
mL	milliliter
µm	micrometer
µmol	micromole
MMAD	mass median aerodynamic diameter
MOA	mechanism of action
MoA	mode of action
mol	mole
mPL	mouse placental lactogen
mPLP	mouse prolactin-like protein
mRNA	messenger ribonucleic acid
MRP	multidrug resistance-associated protein
MTT	3-(4,5-dimethylthiazol-2-yl)-2,5-diphenyltetrazolium bromide
Nd2	NADH dehydrogenase 2
Ndufs8	NADH dehydrogenase iron-sulfur protein 8
ng	nanogram
NHANES	National Health and Nutrition Examination Survey
NIEHS	National Institute for Environmental Health Sciences
NJDEP	New Jersey Department of Environmental Protection
NK	natural killer
NM	not monitored
nmol	nanomolar
NMR	nuclear magnetic resonance
NMRI	Naval Medical Research Institute
NOAEL	no observed adverse effect level
Nrf1	nuclear respiratory factor 1
Nrf2	nuclear respiratory factor 2
NTCP	sodium-taurocholate cotransporting polypeptide
OAT	organic anion transporter
OATP	organic anion transporting polypeptide
OR	odds ratio
OVA	ovalbumin
OVX	ovariectomized
OW	Office of Water
P	progesterone
PACT	pancreatic acinar cell tumor
PAH	polycyclic aromatic hydrocarbon
PB	phenobarbital
PBMC	peripheral blood mononuclear cells
PBPK	physiologically based pharmacokinetic
PCNA	proliferating cell nuclear antigen
PenH	enhanced pause airway respiration
PFAA	perfluoroalkyl acid
PFAS	perfluoroalkyl substance
PFC	plaque-forming cell
PFDA	perfluorodecanoic acid

PFHxA	perfluorohexanoic acid
PFHxS	perfluorohexanesulfonic acid
PFNA	perfluorononanoic acid
PFOA	perfluorooctanoic acid
PFOS	perfluorooctane sulfonate
Pgc-1 α	peroxisome proliferator-activated receptor gamma coactivator 1 α
PH	peroxisomal bifunctional protein
PHA	phytohemagglutinin
PK	pharmacokinetic
pKa	acid dissociation constant
PND	postnatal day
POD	point of departure
PPAR	peroxisome proliferator-activated receptor
ppb	parts per billion
ppm	parts per million
PT	peroxisomal thiolase
PWG	pathology working group
PXR	pregnane X receptor
Q	flow in and out of tissues
Q _{file}	median fraction of blood flow to the filtrate
RfC	reference concentration
RfD	reference dose
RFD	regular fat diet
ROS	reactive oxygen species
RR	relative risk
RSA	rodent serum albumin
RSC	relative source contribution
RT-PCR	reverse transcription polymerase chain reaction
RXR α	retinoid X receptor alpha
SD	standard deviation
SDH	sorbitol dehydrogenase
SDQ	Strengths and Difficulties Questionnaire
SDWA	Safe Drinking Water Act
SHBG	sex hormone-binding globulin
SIAR	SIDS Initial Assessment Report
SIR	standardized incidence ratio
SMR	standardized mortality ratio
SOD	superoxide dismutase
SPI	Society of the Plastics Industry
SRBC	sheep red blood cells
S-TGC	sinusoidal trophoblast giant cells
T3	triiodothyronine
T4	thyroxine
T _{1/2}	elimination half-time
T _m	transporter maximum
T _{max}	time of maximum plasma concentration
TC	total cholesterol
TCPOBOP	1,4-bis[2-(3,5-dichloropyridyloxy)] benzene
Tfam	transcription factor A

TG	triglyceride
TH	tyrosine hydroxylase
TNF α	tumor necrosis factor α
TPO	thyroid peroxidase
TRR	total reactive residues
TSH	thyroid stimulating hormone
TTP	time to pregnancy
TTR	thyroid hormone transport protein, transthyretin
UA	uric acid
UCMR	Unregulated Contaminant Monitoring Rule
UCMR 1	Unregulated Contaminant Monitoring Rule 1
UCMR 2	Unregulated Contaminant Monitoring Rule 2
UF	uncertainty factor
URAT	urate transporter
USGS	U.S. Geological Survey
V _d	volume of distribution
V _{max}	maximum initial rate of an enzyme catalyzed reaction
VLCAD	very long chain acyl-CoA dehydrogenase
VLDL	very low-density lipoprotein
VOC	volatile organic compound
WHO	World Health Organization
WRF	Water Research Foundation

EXECUTIVE SUMMARY

Perfluorooctanoic acid (PFOA) is a synthetic, fully fluorinated, organic acid used in a variety of consumer products and in the production of fluoropolymers and generated as a degradation product of other perfluorinated compounds. Because of strong carbon-fluorine bonds, PFOA is stable to metabolic and environmental degradation. PFOA is one of a large group of perfluoroalkyl substances (PFASs) that are used to make products more resistant to stains, grease, and water. These compounds have been widely found in consumer and industrial products as well as in food items. Major U.S. manufacturers voluntarily agreed to phase out production of PFOA by the end of 2015. Exposure to PFOA in the United States remains possible due to its legacy uses, existing and legacy uses on imported goods, degradation of precursors, and extremely high persistence in the environment and the human body.

Extensive data on humans and animals indicate ready absorption of PFOA and distribution of the chemical throughout the body by noncovalent binding to plasma proteins. Studies of postmortem human tissues identify its presence in liver, lung, kidney, and bone. PFOA is not readily eliminated from the human body as evidenced by the half-life of 2.3 years among members of the general population. In contrast, half-life values for the monkey, rat, and mouse are 20.8 days, 11.5 days, and 15.6 days, respectively.

Human epidemiology data report associations between PFOA exposure and high cholesterol, increased liver enzymes, decreased vaccination response, thyroid disorders, pregnancy-induced hypertension and preeclampsia, and cancer (testicular and kidney). Epidemiology studies examined workers at PFOA production plants, a high-exposure community population near a production plant in the United States (i.e., the C8 cohort), and members of the general population in the United States, Europe, and Asia. These studies examined the relationship between serum PFOA concentration (or other measures of PFOA exposure) and various health outcomes. Exposures in the highly exposed C8 community are based on the concentrations in contaminated drinking water and serum measures. Exposures among the general population typically included multiple PFASs as indicated by serum measurements. The correlation among eight carbon PFASs is often moderately strong (e.g., Spearman $r > 0.6$ for PFOA and perfluorooctane sulfonate (PFOS) in the general population). Mean serum levels among the occupational cohorts ranged from approximately 1 to 4 micrograms per milliliter ($\mu\text{g/mL}$) and in the C8 cohort ranged from 0.01 to 0.10 $\mu\text{g/mL}$. Geometric mean serum values for the National Health and Nutrition Examination Survey (NHANES) general population (\geq age 12; 2003–2008) were 0.0045 $\mu\text{g/mL}$ for males and 0.0036 $\mu\text{g/mL}$ for females.

These epidemiology studies have generally found positive associations between serum PFOA concentration and total cholesterol (TC) in the PFOA-exposed workers and the high-exposure community (i.e., increasing lipid level with increasing PFOA); similar patterns are seen with low-density lipoproteins (LDLs) but not with high-density lipoproteins (HDLs). These associations were seen in most of the general population studies, but similar results also were seen with PFOS, and the studies did not always adjust for these correlations. Associations between serum PFOA concentrations and elevations in serum levels of alanine aminotransferase (ALT) and gamma-glutamyl transpeptidase (GGT) were consistently observed in occupational cohorts, the high-exposure community, and the U.S. general population. The associations are not large in magnitude, but indicate the potential for PFOA to affect liver function.

Diagnosed thyroid disease in females and female children was increased both in the high-exposure C8 study population and in females with background exposure; thyroid hormones are not consistently associated with PFOA concentration. Associations between PFOA exposure and risk of infectious diseases (as a marker of immune suppression) were not identified, but a decreased response to vaccines in relation to PFOA exposure was reported in studies in adults in the high-exposure community population and in studies of children in the general population; in the latter studies, it is difficult to distinguish associations with PFOA from those of other correlated PFASs. Studies in the high-exposure community reported an association between serum PFOA and risk of pregnancy-related hypertension or preeclampsia, conditions related to renal function during pregnancy; this outcome has not been examined in other populations. An inverse association between maternal PFOA (measured during the second or third trimester) or cord blood PFOA concentrations and birth weight was seen in several studies. It has been suggested that low glomerular filtration rate (GFR) can impact fetal birth weight (Morken et al. 2014). Pharmacokinetic (PK) analyses have shown, however, that in individuals with low GFR, there are increased levels of serum PFOA and lower birth weights. Thus, the impact on body weight is likely due to a combination of the low GFR and the serum PFOA.

The epidemiology studies did not find associations between PFOA and diabetes, neurodevelopmental effects, or preterm birth and other complications of pregnancy. Developmental outcomes including delayed puberty onset in girls also have been reported; however, in the two studies examining PFOA exposure in relation to menarche, conflicting results were observed: either no association or a possible indication of an earlier menarche seen with higher maternal PFOA levels in one study and a later menarche seen with higher maternal PFOA levels in the other study. Increased risk of ulcerative colitis was reported in the high-exposure community study as well as in a study limited to workers in that population.

For PFOA, oral animal studies of short-term subchronic and chronic duration are available in multiple species including monkeys, rats, and mice. These studies report developmental effects, liver and kidney toxicity, immune effects, and cancer (liver, testicular, and pancreatic). Developmental effects observed in animals include decreased survival, delayed eye opening and reduced ossification, skeletal defects, altered puberty (delayed vaginal opening in females and accelerated puberty in males), and altered mammary gland development.

In most animal studies, changes in relative and/or absolute liver weight appear to be the most common effect observed with or without other hepatic indicators of adversity, identifying increased liver weight as a common indicator of PFOA exposure. The liver also contains the highest levels of PFOA when analyzed after test animal sacrifice. The increases in liver weight and hypertrophy, however, also can be associated with activation of cellular peroxisome proliferator-activated receptor α (PPAR α) receptors, making it difficult to determine if this change is a reflection of PPAR α activation or an indication of PFOA toxicity. The PPAR α response is greater in rodents than it is in humans. The U.S. Environmental Protection Agency (EPA) evaluated liver disease and liver function resulting from PFOA exposure in studies where liver weight changes and other indicators of adversity such as necrosis, inflammation, fibrosis, and/or steatosis (fat accumulation in the liver) or increases in liver or serum enzymes indicative of liver damage were observed.

In repeat PFOA dosing studies, rats given 0.64 milligrams per kilogram per day (mg/kg/day) for 13 weeks and monkeys given 3 mg/kg/day for 26 weeks had increased liver weight accompanied by hepatocellular hypertrophy. As part of a two-generation study, male rats had increased liver and kidney weights as well as decreased body weight at 1 mg/kg/day. In shorter term studies, slightly higher or lower doses to rats resulted in increased liver weight, liver necrosis, and developmental delays. In mice, developmental toxicity and increased spleen weight was observed at a dose of 1 mg/kg/day accompanied by increased liver weight. Other doses of similar magnitudes in mice were associated with developmental delays and liver necrosis. Slightly higher doses resulted in decreased immunoglobulin levels. As supported by the epidemiology data, suppression of the immune system in response to PFOA exposure is an area of concern for humans as well as animals.

PFOA is known to activate PPAR pathways by increasing transcription of mitochondrial and peroxisomal lipid metabolism, sterol, and bile acid biosynthesis and retinol metabolism genes. Based on PFOA-induced transcriptional activation of many other genes in PPAR α -null mice, however, other receptors such as the constitutive androstane receptor (CAR), farnesoid receptor (FXR), and pregnane X receptor (PXR) could be involved in PFOA-induced toxicity.

EPA used a peer-reviewed PK model to calculate the average serum concentrations associated with candidate no observed adverse effect levels (NOAELs) and lowest observed adverse effect levels (LOAELs) from six studies for multiple effects to calculate corresponding human equivalent doses (HEDs) for the derivation of candidate reference doses (RfDs). Overall, the toxicity studies available for PFOA demonstrate that the developing fetus is particularly sensitive to PFOA-induced toxicity. In addition to the critical developmental effects described above, other adverse effects include decreased survival, delays in eye opening and ossification, skeletal defects, delayed vaginal opening in females, and altered mammary gland development.

The EPA Office of Water (OW) selected an RfD of 0.00002 mg/kg/day based on effects observed in a developmental toxicity study in mice for PFOA (Lau et al. 2006). The RfD is based on reduced ossification and accelerated puberty (in males). The total uncertainty factor (UF) applied to the HED LOAEL from Lau et al. (2006) is 300 and includes a UF of 10 for intrahuman variability, a UF of 3 to account for toxicodynamic differences between animals and humans, and a UF of 10 to account for use of a LOAEL as the point of departure (POD).

Decreased pup body weights also were observed in studies conducted in mice receiving external doses within the same order of magnitude (1, 3, and 5 mg/kg/day, respectively) as those chosen for the RfD. These studies, however, lacked serum levels and were not amenable to modeling. Overall, the developmental and reproductive toxicity studies available for PFOA demonstrate that the developing fetus is particularly sensitive to PFOA-induced toxicity. The selected RfD is supported by the other candidate RfDs (also 0.00002 mg/kg/day) based on effects on the immune system in a 15-day short-term study by DeWitt et al. (2008) and on the kidneys of F0 and F1 males in a two-generation study of developmental and reproductive toxicity.

Under EPA's *Guidelines for Carcinogen Risk Assessment* (USEPA 2005a), there is "suggestive evidence of carcinogenic potential" for PFOA. Epidemiology studies demonstrate an association of serum PFOA with kidney and testicular tumors among highly exposed members of the general population. Two chronic bioassays of PFOA support a positive finding for its ability to be tumorigenic in one or more organs of rats, including the liver, testes, and pancreas. EPA estimated a cancer slope factor (CSF) of 0.07 (mg/kg/day)⁻¹ based on testicular tumors. As a

comparative analysis, the concentration of PFOA in drinking water that would have a one-in-a-million increased cancer risk was calculated using the oral slope factor for testicular tumors, assuming a default adult body weight of 80 kg and a default drinking water intake (DWI) rate of 2.5 liter per day (L/day) (USEPA 2011). This concentration is lower than the concentration for cancer (also derived with adult exposure values), indicating that a guideline derived from the developmental endpoint will be protective for the cancer endpoint.

1 IDENTITY: CHEMICAL AND PHYSICAL PROPERTIES

Perfluorooctanoic acid (PFOA) is a completely fluorinated organic synthetic acid used to produce fluoropolymers. It is manufactured by the Simons electrochemical fluorination (ECF) process or by telomerization. In the ECF process, the carbon-hydrogen bonds on molecules of organic feedstock are replaced with carbon-fluorine bonds when an electric current is passed through a solution of hydrogen fluoride and the organic feedstock. In the telomerization process, fluorine-bearing chemicals and tetrafluoroethylene react to produce fluorinated intermediates that are converted into PFOA (HSDB 2006). The telomerization process produces linear chains (Beesoon et al. 2011). Ammonium perfluorooctanoate (APFO) is the salt of PFOA and is a processing aid in the manufacture of certain fluoropolymers, especially as an emulsifier in aqueous solution during the emulsion polymerization of tetrafluoroethylene (see Figure 1-1). APFO is not consumed during the polymerization process (SPI 2005). Some sources of PFOA in the atmosphere result from the atmospheric degradation or transformation or surface deposition of precursors, including related fluorinated chemicals (e.g., fluorotelomer alcohols, olefins, and perfluoroalkyl sulfonamide substances) (Wallington et al. 2006).

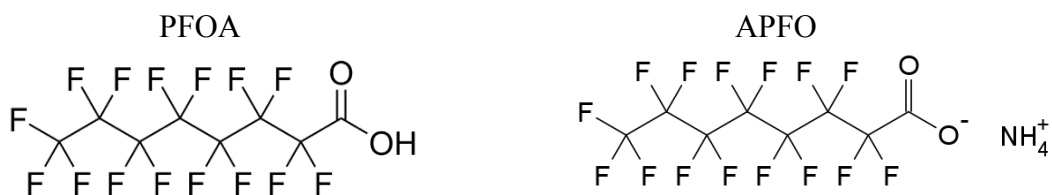

Source: SIAR 2006

Figure 1-1. Chemical Structures of PFOA and APFO

Although PFOA is not a polar molecule, each of the carbon fluoride bonds is a dipole as a result of the electronegativity difference between fluoride (4.1) and carbon (2.5), placing a partial negative charge on each of the covalently bound fluorines and a partial positive charge on each of the fluorinated carbons. Charge repulsion of the partially negative fluorines and steric factors favor a PFOA conformation in which carbons 2 through 7 adopt an *anti* arrangement of substituents resulting in a fairly linear molecular shape as the lowest energy conformer (see Figure 1-2 and Figure 1-3).

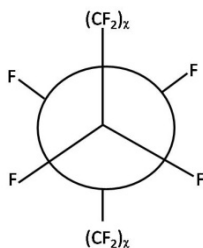

Figure 1-2. PFOA Anti-Conformer

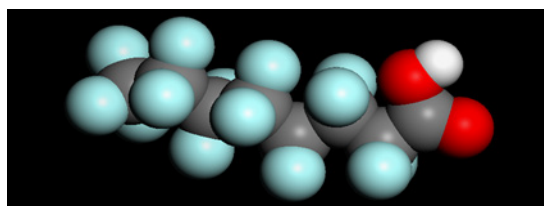

Figure 1-3. PFOA Lowest Energy Conformer

The favored PFOA conformer is very similar to the preferred conformation of the eight-carbon fatty acid, octanoic acid (also known as caprylic acid) except for the sphere of partial negative charge on the fluorines of the exterior surface. The ionized carboxylate grouping and the fluorine's partial negative charges favor electrostatic interactions between PFOA and positively charged surfaces on proteins and other macromolecules.

The ECF process produces branched chain isomers, about 80% linear and 20% branched (Loveless et al. 2008). The samples studied by Loveless et al. (2008) had the following mole (mol) percents of branched chain isomers: 12.6% internal monomethyl (nonalpha), 9% isopropyl, 0.2%, *tert*-butyl, 0.1 gem-dimethyl, and 0.1 alpha monomethyl. A study by Yoshikane et al. (2010) reported finding perfluoro-6-methylheptanoic acid (the isopropyl isomer) using mass spectroscopy analysis of environmental fluorosurfactants in Japan. Branched chain samples evaluated by Beeson and Martin (2015) had a 7 carbon linear chain with methyl groups on carbons 3, 4, 5, or 6, designated as 3m, 4m, 5m, or 6m (iso), respectively. The composition of a PFOA product is important because the toxicokinetic and physiological properties of the linear and branched chain isomers are different. The nomenclature for the branched chain isomers varied between authors and indicates that differences exist in the composition of the commercial products that were evaluated.

The physical and chemical properties and other reference information for PFOA and its salt APFO are provided in Table 1-1. These properties help to define the behavior of PFOA in living systems and the environment. PFOA and its salt are highly stable compounds. They are solids at room temperature with low vapor pressures. The melting point for PFOA is identified as 54.3 degrees Celsius, and vapor pressures increase at temperatures near the melting point.

PFOA is moderately soluble in water and APFO is even more soluble. Both compounds are considered insoluble in nonpolar solvents, which results in their being described as oleophobic. Water solubility is increased by the presence of other ions and is an important factor governing solubility in body fluids. As the concentration of PFOA in aqueous solution increases, it forms colloidal micelles with the carboxyl functional groups on the exterior and the fluorocarbon chain on the interior. The critical micelle concentration has been identified as 3.6–3.7 g/L. Once the critical concentration has been reached, micelles will form and the PFOA molecules will colloiddally distribute in the aqueous environment. At levels below the critical micelle concentration, the individual molecules are individually distributed in the solvent.

The acid dissociation constant (pKa) for PFOA has been reported as 2.8. As a result, it will be present in most biological fluids (gastric secretions excluded) primarily as the perfluorooctanoate anion. This is an important feature in governing absorption and membrane transport.

Table 1-1. Chemical and Physical Properties of PFOA

Property	Perfluorooctanoic Acid	Source
Chemical Abstracts Service Registry No. (CASRN) ^a	335-67-1	
CA Index Name	2,2,3,3,4,4,5,5,6,6,7,7,8,8,8-pentadecafluorooctanoic acid	
Synonyms	PFOA; Pentadecafluoro-1-octanoic acid; Pentadecafluoro-n-octanoic acid; Octanoic acid, pentadecafluoro-; Perfluorocaprylic acid; Pentadecafluorooctanoic acid; Perfluoroheptanecarboxylic acid	
Chemical Formula	C ₈ HF ₁₅ O ₂	
Molecular Weight (g/mol)	414.09	(HSDB 2012); (Lide 2007); (SRC 2016)
Color/Physical State	White powder (ammonia salt)	(HSDB 2012); (Lewis 2004)
Boiling Point	192.4 °C; Stable when bound	(HSDB 2012); (Lide 2007); (SRC 2016)
Melting Point	54.3 °C	(HSDB 2012); (Lide 2007); (SRC 2016)
Vapor Pressure	0.525 mm Hg at 25 °C (measured) 0.962 mm Hg at 59.25 °C (measured)	(Hekster et al. 2003); (HSDB 2012); (SRC 2016) (ATSDR 2015); (Kaiser et al. 2005)
Henry's Law constant	Not measureable	(ATSDR 2015)
pKa	2.80	(SRC 2016)
K _{oc}	2.06	(Higgins and Luthy 2006)
K _{ow}	Not measurable	(ATSDR 2015); (EFSA 2008)
Solubility in water	9.50 x 10 ³ mg/L at 25 °C (estimated)	(ATSDR 2015); (Hekster et al. 2003); (HSDB 2012); (Kauck and Diesslin 1951); (SRC 2016)
Half-life in water (25°C)	Stable	(UNEP 2015)
Half-life in air	Stable when bound	(UNEP 2015)

Note: ^aThis CASRN is for linear PFOA, but the toxicity studies are based on a mixture of linear and branched and the RfD applies to both.

2 TOXICOKINETICS

PFOA is stable to metabolic and environmental degradation because of strong carbon-fluorine bonds. It also is resistant to metabolic biotransformation. Thus, the toxicity of the parent compound is the concern. Because of its impact on cellular receptors and proteins, it possesses the ability to impact the biotransformation of dietary constituents, intermediate metabolites, and other xenobiotic chemicals by altering enzyme activities and transport kinetics. PFOA is known to activate PPAR pathways by increasing transcription of mitochondrial and peroxisomal lipid metabolism, sterol, and bile acid biosynthesis and retinol metabolism genes. Based on transcriptional activation of many genes in PPAR α -null mice, however, the effects of PFOA involve far more than activation of PPAR and consequent peroxisome proliferation. The data indicate that it also can activate the CAR, FXR, and PXR and metabolic activities linked to these nuclear receptors.

PFOA is not readily eliminated from humans and other primates. Toxicokinetic profiles and the underlying mechanism for half-life differences are not completely understood, although many of the differences appear to be related to elimination kinetics and factors that control membrane transport. Thus far, three transport families appear to play a role in PFOA absorption, distribution, and excretion: organic anion transporters (OATs), organic anion transporting polypeptides (OATPs), and multidrug resistance-associated proteins (MRPs) (Klaassen and Aleksunes 2010; Launay-Vacher et al. 2006). The transporters are critical for gastrointestinal absorption, uptake by the tissues, and excretion via bile and the kidney. These transport systems are located at the membrane surfaces of the intestines, liver, lungs, heart, blood brain barrier, blood placental barrier, blood testes barrier, and mammary glands where they function to protect the organs, tissues, and fetus from foreign compounds (Ito and Alcorn 2003; Klaassen and Aleksunes 2010, Zaïr et al. 2008).

There are differences in transporters across species, genders, and individuals. For example, more PFOA-specific information is available about the OAT and OATP families than about the MRPs. These limitations have hindered the development of PK models for use in predicting effects in humans based on the data from animal studies. Abbreviations for the various transporters are not totally standardized, and there are inconsistencies across individual publications. The current convention for distinguishing between the transporters in humans and those in animals is to use uppercase letters for humans and lowercase letters for animals. In this document, uppercase letters are used uniformly, thus, the abbreviations indicate the transporter family and not the species studied.

2.1 Absorption

Absorption data are available for oral, inhalation, and dermal exposure in laboratory animals, and extensive data are available from humans demonstrating the presence of PFOA in serum. These data demonstrate absorption by one or more routes but do not quantify the amounts absorbed relative to dose.

The absorption process requires transport across the interface of the gut, lung, and skin with the external environment. Since PFOA is moderately soluble in aqueous solutions and oleophobic (i.e., minimally soluble in body lipids), movement across the apical and basal membrane surfaces of the lung, gastrointestinal tract, and skin involves transporters or mechanisms other than simple diffusion across the lipid bilayer. As discussed above, there are

data that identify involvement of OATs, OATPs, and MRPs in enterocytes in uptake of PFOA (Klaassen and Aleksunes 2010; Zair et al. 2008). OAT2, OAT3, OATP2b1, and MRP2 are located in the apical membrane of the microvilli, and MRP1, 3, and 4 are located along the basolateral membrane. Together they function in the uptake of organic anions from gastrointestinal contents and transport of those anions into the portal blood supply (Zair et al. 2008). Few studies have been conducted of the intestinal transporters for PFOA in humans or laboratory animals. Most of the research has focused on the kidney and has been carried out using cultured carrier cells transfected with the transporter proteins.

2.1.1 Oral Exposure

Based on animal data, PFOA is well absorbed following oral exposure. Gibson and Johnson (1979) administered a single dose of ¹⁴C-PFOA averaging 11.4 mg/kg by gavage to groups of three male 10-week-old CD rats. Twenty-four hours after administration, at least 93% of total carbon-14 was absorbed. In another study, Cui et al. (2010) exposed male Sprague-Dawley rats (10 per group) to PFOA (96% active ingredient) at 0, 5, and 20 mg/kg/day once daily by gavage for 28 days. The percent of the dose absorbed was 92.8% and 92.3% for the low and high dose, respectively, under the assumption that fecal excretion over the first 24 hours after dosing was estimated to be unabsorbed material and did not include biliary loss.

The data from studies of adverse effects on monkeys, rats, and mice receiving PFOA in capsules, food, or drinking water demonstrate gastrointestinal absorption. In cynomolgus monkeys, steady-state serum PFOA levels were reached within 4–6 weeks after dosing with capsules containing 3, 10, and 20 mg/kg PFOA for 6 months (Butenhoff et al. 2004b). Urine steady-state levels were reached after 4 weeks. Serum PFOA concentration in male rats fed diets containing 0.06, 0.64, 1.94, and 6.5 mg PFOA/kg for 90 days was 7.1, 41, 70, and 138 µg/mL, respectively (Perkins et al. 2004). Peak blood levels of PFOA were attained 1–2 hours following a 25-mg/kg dose to male and female rats (Kennedy et al. 2004). Blood levels of PFOA over time were similar in female rats given a single dose of 25 mg PFOA/kg to a female rat given 10 daily doses of 25 mg PFOA/kg (Kennedy et al. 2004). Plasma PFOA concentrations in male Sprague-Dawley rats fed a diet containing 300 parts per million (ppm) PFOA for 1, 7, and 28 days were 259, 234, and 252 µg/mL, respectively (Elcombe et al. 2010).

In rats, a marked gender difference in serum and tissue levels exists following PFOA administration. Males consistently have much higher levels than females with the difference maintained and becoming more pronounced over time. Female rats show much greater urinary excretion of PFOA than do male rats with serum half-life values in hours for females compared with days for males. These differences account for variability in postexposure serum concentrations between males and females.

2.1.2 Inhalation Exposure

Hinderliter (2003) measured the serum concentrations of PFOA following single and repeated inhalation exposures in Sprague-Dawley rats. For the single-exposure study, male and female rats (3/gender/group) were exposed to a single nose-only exposure of an aerosol of 0, 1, 10, and 25 mg/m³ PFOA. Preliminary range-finding studies demonstrated that aerosol particle sizes were 1.8–2.0 µm mass median aerodynamic diameter (MMAD) with geometric standard deviations (GSDs) ranging from 1.9 to 2.1 µm. Blood samples were collected before exposure; at 0.5, 1, 3, and 6 hours during exposure; and at 1, 3, 6, 12, 18, and 24 hours after exposure. Plasma

was analyzed by liquid chromatography-mass spectrometry (LC-MS). PFOA plasma concentrations increased proportional to aerosol exposure concentrations.

The male plasma C_{\max} values were approximately 2–3 times higher than the female C_{\max} . The female C_{\max} occurred approximately 1 hour after the exposure period with plasma concentrations then declining. In males, C_{\max} was observed immediately after the exposure period ended and persisted for up to 6 hours. The data are illustrative of absorption of PFOA via inhalation and are consistent with the gender differences in rate of excretion.

2.1.3 Dermal Exposure

There is evidence that PFOA is absorbed following dermal exposure. Kennedy (1985) treated rabbits and rats dermally with a total of 10 applications of PFOA at doses of 0, 20, 200, and 2,000 mg/kg. Treatment resulted in elevated blood organofluorine levels that increased in a dose-related manner. Organofluorine was measured because, at the time of the study, reliable analytical techniques for measuring serum or plasma PFOA were still under development. O'Malley and Ebbens (1981) treated groups of two male and two female New Zealand White rabbits dermally with doses of 100, 1,000, and 2,000 mg/kg PFOA for 14 days. Mortality among the exposed animals demonstrated dermal uptake. All of the animals died at the highest dose, three of four died in the mid-dose group, and none in the low-dose group. Although these data demonstrate dermal absorption, they do not provide quantitative dose-response data for effects other than mortality.

The results of *in vitro* percutaneous absorption studies of PFOA through rat and human skin have been reported (Fasano et al. 2005). The permeability coefficient for PFOA was calculated to be $3.25 \pm 1.51 \times 10^{-5}$ centimeters per hour (cm/h) and $9.49 \pm 2.86 \times 10^{-7}$ cm/h in rat and human skin, respectively.

2.2 Distribution

Distribution of absorbed material requires vascular transport from the portal of entry to receiving tissues. It has been suggested that PFOA circulates in the body by noncovalently binding to plasma proteins. Several studies have investigated the binding of PFOA to plasma proteins in rats, humans, or monkeys to gain an understanding of its absorption, distribution, and elimination as well as information on species and gender differences.

Protein Binding. Protein binding in plasma from cynomolgus monkeys, rats, and humans was tested with PFOA via *in vitro* methods (Kerstner-Wood et al. 2003). The results are summarized in Table 2-1. Rat, human, and monkey plasma proteins were able to bind 97–100% of the PFOA added at concentrations ranging from 1 to 500 ppm. Human serum albumin (HSA) carried the largest portion of the PFOA among the protein components of human plasma. Serum albumin is a common carrier of hydrophobic materials in the blood, including short- and medium-chain fatty acids, thyroxine (T4), heme, inorganic ions, and some pharmaceuticals (Fasano et al. 2005). Approximately 60% of the serum protein in humans and rats is albumin (Harkness and Wagner 1983; Saladin 2004). At 68%, the percentage bound to albumin in mice is slightly higher than in humans and rats (Harkness and Wagner 1983).

Table 2-1. Protein Binding in Rat, Human, and Monkey Plasma

PFOA Concentration (ppm)	Rat (%)	Monkey (%)	Human (%)
1	~100	~100	~100
10	99.5	99.8	99.9
100	98.6	99.8	99.9
250	97.6	99.8	99.6
500	97.3	99.5	99.4

Source: Kerstner-Wood et al. 2003

Note: % binding values reported as “~100” reflect a nonquantifiable amount of test article in the plasma water below the quantifiable limit <6.25 ng/mL.

Han et al. (2003) investigated the binding of PFOA to rat and human plasma proteins *in vitro*. The authors concluded that there was no correlation between the PFOA persistence and binding of the PFOA to rat serum. The primary PFOA binding protein in plasma was serum albumin. However, the method used (ligand blotting) would not theoretically allow the identification of low-abundance proteins with high affinity for PFOA. Further investigation of purified rodent and HSA binding using labeled ¹⁹F nuclear magnetic resonance (NMR) allowed the calculation of disassociation constants for PFOA binding to rodent and HSA. No significant difference in binding to the serum albumin of rat versus human was detected (Table 2-2).

Male and female rats treated *in vivo* showed no gender difference in the binding of PFOA to serum proteins though the persistence of PFOA *in vivo* is much greater in male than female rats.

Table 2-2. Dissociation Constants (K_d) of Binding Between PFOA and Albumin

Parameter	Method	RSA	HSA
K _d (mM)	NMR ^a	0.29 ± 0.10 ^c	
K _d (mM)	micro-SEC ^b	0.36 ± 0.08 ^c	0.38 ± 0.04
Number of Binding Sites	micro-SEC ^b	7.8 ± 1.5	7.2 ± 1.3

Source: Han et al. 2003

Notes:

RSA = rodent serum albumin; HSA= human serum albumin

a = Average of the two K_d values (0.31 ± 0.15 and 0.27 ± 0.05 mM) obtained by NMR.

b = Values were obtained from three independent experiments and their SDs are shown.

c = On the basis of the result of unpaired t-test at 95% confidence interval, the difference of K_d values determined by NMR and micro-SEC is statistically insignificant.

Wu et al. (2009) examined the interaction of PFOA and HSA. The authors tested their hypothesis that PFOA, after absorption, was transported bound to albumin by dialyzing PFOA solutions in the presence and absence of HSA. In the absence of HSA, 98% of the dissolved PFOA crossed the dialysis membrane into the dialysate within 4 hours. In the presence of HSA, the amount of PFOA found in the dialysate after 4 hours decreased in direct proportion to the albumin concentration, demonstrating binding to the protein. No albumin was identified in the dialysate.

Using the dialysis data and thermodynamic considerations, the authors concluded that albumin could bind up to 12 PFOA molecules on its surface via chemical monolayer absorption with a 13th molecule bound noncovalently in the more hydrophobic interior of the protein. The surface nature of the binding could well indicate potential binding to other serum proteins as well. Circular dichroism measurements of the albumin/PFOA complex suggested a conformational change in the protein as a result of the PFOA binding. The beta-pleated sheet

content of the albumin decreased, and the alpha-helix content increased by 15%. These conformational changes could interfere with the functional properties of serum albumin or other serum proteins impacted by surface monolayers of PFOA. For example, albumin's ability to transport its natural ligands could be decreased by the presence of PFOA on the protein surface. The interaction of albumin with target cellular receptors also could be altered.

MacManus-Spencer et al. (2010) used a variety of approaches to quantify the binding of PFOA to serum albumin (e.g., surface tension measurements, ^{19}F NMR spectroscopy, and fluorescence spectroscopy). When taken together, the results from these analyses suggest the presence of primary and secondary binding sites on albumin. The PFOA-albumin association constants for the primary site (K_1^a) was about $1.5 \pm 0.2 \times 10^5/\text{mol}$ bovine serum albumin (BSA) while the association constant for the secondary site (K_2^a) was $0.8 \pm 0.1 \times 10^2/\text{mol}$ BSA at a concentration of $1\ \mu\text{mol}$. When the concentration of BSA increased to $10\ \mu\text{mol}$, the binding per mol of BSA decreased $K_1^a = 0.33 \pm 0.004$ and $K_2^a = 0.53 \pm 0.1$. Qin et al. (2010) also used fluorescence spectroscopy quenching analysis to study PFOA binding to BSA and concluded that van der Waals forces and hydrogen bonds were the dominant intermolecular binding forces.

The results of the fluorescence spectroscopy suggested a conformational change in BSA following binding of PFOA that moved a tryptophan residue (#214) from a slightly polar region of the protein to a less polar region. The shift in a tryptophan position is consistent with the observations of Wu et al. (2009) and Qin et al. (2010), who reported that BSA underwent a conformational change following the binding of PFOA. The authors considered the results from the fluorescence spectroscopy to be relevant to the potential physiological impact of PFOA at levels found in the environment. Because serum albumin is a carrier for a variety of endogenous and exogenous substrates, a change in conformation can alter the bonding constants between albumin and other serum constituents.

A modeling study by Salvalaglio et al. (2010) was conducted to determine the binding sites of PFOA on HSA and classify them by their interaction energy using molecular modeling; this study builds on the binding studies of Wu et al. (2009) and MacManus-Spencer et al. (2010). It was estimated that the maximum number of PFOA binding sites on HSA was nine. The site locations were common to the natural binding sites for fatty acids, T4, Warfarin, indole, and benzodiazepine (see Figure 2-1) (Salvalaglio et al. 2010). The binding site closest to tryptophan residue #214 had the highest binding affinity (-8.0 kilocalorie/mol).

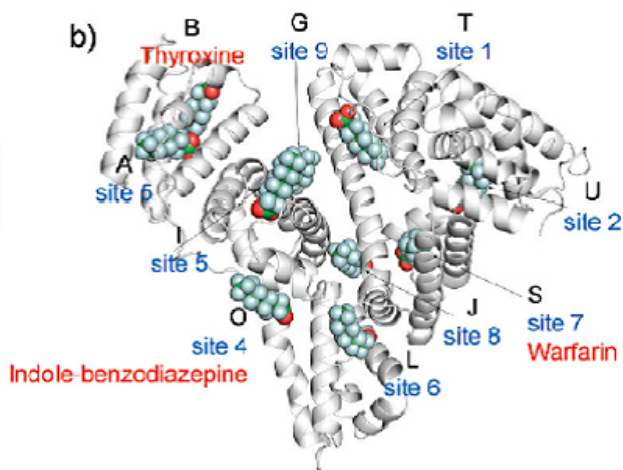

Figure 2-1. PFOA Binding Sites on HSA

Weiss et al. (2009) screened several perfluorinated compounds (n = 30), differing by carbon chain length C4–18, fluorination degree, and functional groups for potential binding to the serum thyroid hormone transport protein, transthyretin (TTR), using a radioligand-binding assay. The natural ligand of TTR is T4. PFOA was one of the chemicals evaluated. Human TTR was incubated overnight with ¹²⁵I-labeled T4, unlabeled T4, and 10-10,000 nanomolar (nmol) PFOA as a competitor for the T4 binding sites. The unlabeled T4 was used as a reference compound. The levels of T4 in the assay were close to the lower range for total T4 measured in healthy adults. The authors concluded that binding affinity for TTR was highest for the fully fluorinated compounds tested and those having at least an eight carbon length chain, characteristics that apply to PFOA. PFOA demonstrated a high binding affinity for TTR with 949 nmol, causing a 50% inhibition of T4 binding to the TTR.

Beesoon and Martin (2015) examined differences in the binding of the linear and branched chain isomers to serum albumin and human serum proteins. The linear PFOA molecule was found to bind more strongly to calf serum albumin than the branched chain isomers. When arranged in order of increasing binding, the order was 4m < 3m < 5m < 6m (iso) < linear. In the isomer-specific binding to spiked total human serum protein, the linear molecule clearly had the strongest binding potential with about 7–10% free. The relationship for the other isomers was 5m > 6m > 4m > 3m (15–30% free). Binding was estimated based on the concentrations in the ultrafiltrate after spiking with 5–60 mg/L of technical PFOA. The human serum was diluted tenfold before spiking.

When incubated with separate human-derived plasma protein fractions (Kerstner-Wood et al. 2003), PFOA was highly bound (99.7%) to albumin and showed some affinity for LDLs, formerly beta-lipoproteins (9.6%) with limited binding to alpha-globulins (11.0%) and gamma-globulins (3.0%). Low levels of binding to alpha-2-macroglobulin and transferrin were measured when the protein concentrations were approximately 10% of physiological concentration (see Table 2-3).

Table 2-3. Percent (%) Binding of PFOA to Human Plasma Protein Fractions

Fraction	~10% Physiological Conc.	100% Physiological Conc.
Albumin	96.4	99.7
Gamma-globulin	3.5	3.0
Alpha-globulin	28.5	11.0
Fibrinogen	5.4	<0.1
Alpha-2-macroglobulin	7.9	<0.1
Transferrin	1.0	2.1
LDLs	19.6	39.6

Source: Kerstner-Wood et al. 2003

It also is possible that PFOA will display nonspecific binding to proteins within the cellular matrix as well as in the serum but little work has been done to investigate that probability.

Luebker et al. (2002) conducted *in vitro* studies of the ability of a variety of perfluorinated chemicals to displace a fluorescent substrate (11-(5-dimethylamino-naphthalenesulphonyl)-undecanoic acid) from liver fatty acid binding protein (L-FABP). L-FABP is an intracellular lipid carrier protein that reversibly binds long-chain fatty acids, phospholipids, and an assortment of peroxisome proliferators (Erol et al. 2003). It constitutes 2–5% of the cytosolic protein in hepatocytes. Luebker et al. (2002) reported that PFOA (IC₅₀>10µmol) exhibited some binding to

L-FABP, but the binding potential was only about 50% of that for PFOS ($IC_{50} = 4.9 \mu\text{mol}$) and far less than that of oleic acid ($IC_{50} = 0.01 \mu\text{mol}$).

L. Zhang et al. (2013) cloned the human L-FABP gene and used it to produce purified protein for evaluation of the binding of PFOA and other PFASs. Nitrobenzoxadiazole-labeled lauric acid was the fluorescent substrate used in the displacement assays. IC_{50} values and dissociation constants were generated for the PFASs studied. Oleic and palmitic acids served as the normal substrates for L-FABP binding. The nitrobenzoxadiazole-labeled lauric acids indicated that there were two distinct binding sites for fatty acids in human FABP with the primary site having a twentyfold higher affinity than the secondary site. The IC_{50} value for PFOA was $9.0 \pm 0.7 \mu\text{mol}$, suggesting that it has a lower binding affinity than PFOS ($IC_{50} = 3.3 \pm 0.1 \mu\text{mol}$). A similar approach was used to compare perfluorohexanoic acid (PFHxA), perfluorohexanesulfonic acid (PFHxS), PFOA, and perfluorononanoic acid (PFNA). The affinity of PFNA for human L-FABP was found to be greater than that for PFOA. The affinities of PFHxA and PFHxS for the protein were much lower. Both PFOA and PFNA bound to the carrier protein in a 1:1 ratio and the interaction was mediated by electrostatic interactions and hydrogen binding of the PFAS with the fatty acid binding site.

2.2.1 Oral Exposure

Tissue Distribution

Human. No clinical studies are available that examined tissue distribution in humans following administration of a controlled dose of PFOA. However, samples collected in biomonitoring and epidemiology studies provide data showing distribution of PFOA. Olsen et al. (2001a) analyzed human sera and postmortem liver samples and found that more than 90% of the liver samples ($n = 30$) were < limit of quantitation (LOQ). Serum levels ranged from <LOQ–7.0 nanograms per milliliter (ng/mL). PFOA concentrations above the LOQ were detected in 5/6 postmortem liver samples from males in Catalonia, Spain. In females, only 1/6 liver samples was above LOQ (Kärman et al. 2009). Pirali et al. (2009) measured intrathyroidal PFOA levels (0.4–6.0 ng/g) in thyroid surgical patients and found no correlation between serum and thyroid PFOA concentration. PFOA has been detected in breast milk samples (Tao et al. 2008; Völkel et al. 2008) and cord blood samples (Apelberg et al. 2007; Monroy et al. 2008) at concentrations above the LOQ. These studies indicate that PFOA is distributed within the body and that maternal transfer to offspring can occur.

Pérez et al. (2013) collected tissue samples from 20 adult subjects (aged 28–83) who had been living in Catalonia, Spain, for 10 years and died of a variety of causes. Autopsies and tissue collection (liver, kidney, brain, lung, and bone) were carried out in the first 24 hours after death. The tissues were analyzed for 21 perfluorinated compounds. PFOA was present in 45% of the samples but could be quantified in only 20% (median 1.9 ng/g). PFOA accumulated primarily in the bone (60.2 ng/g), lung (29.2 ng/g), liver (13.6 ng/g), and kidney (2.0 ng/g), with levels below detection in brain based on the mean wet weight tissue concentrations. Detection levels varied with the tissue evaluated.

Animal. Studies of tissue distributions are available for several species including monkeys, rats, and mice. The data are categorized by species in the sections that follow. The distribution data derived from studies during pregnancy and lactation follow the data on nonpregnant animals.

Monkey. Butenhoff et al. (2002, 2004b) studied the fate of PFOA in cynomolgus monkeys in a 6-month oral exposure study. Groups of four to six male monkeys each were administered PFOA daily via oral capsule at dose rates (DRs) of 0, 3, 10, or 20 mg/kg. The highest dose was initially 30 mg/kg, but due to its toxicity, it was suspended after 12 days. Dosing was resumed on test day 22 using the 20 mg/kg/day dose for the remainder of the 6-month period, resulting in a normalized dose of 20 mg/kg/day for the study. Serum, urine, and fecal samples were collected at 2-week intervals and were analyzed for PFOA concentrations. Liver samples were collected at time of sacrifice.

Serum concentrations reached steady-state levels within 4–6 weeks in all dose groups. Steady-state concentrations of PFOA in serum were 77 ± 39 , 86 ± 33 , and 158 ± 100 $\mu\text{g/ml}$ after 6 weeks and 81 ± 40 , 99 ± 50 , and 156 ± 103 $\mu\text{g/ml}$ after 6 months for the 3-, 10-, and 20-mg/kg dose groups, respectively (Butenhoff et al. 2002, 2004b). The mean serum concentration of PFOA in control monkeys was 0.134–0.203 $\mu\text{g/ml}$. Urine PFOA concentrations reached steady state after 4 weeks and were 53 ± 25 , 166 ± 83 , and 181 ± 100 $\mu\text{g/ml}$ in the 3, 10, and 20-mg/kg dose groups, respectively, for the duration of the study. Liver PFOA concentrations at terminal sacrifice in the 3-mg/kg and 10-mg/kg dose groups were similar and ranged from 6.29 to 21.9 $\mu\text{g/g}$. Liver PFOA concentrations in two monkeys exposed to 20 mg/kg were 16.0 and 83.3 $\mu\text{g/g}$. Liver PFOA concentrations in two monkeys dosed with 10 mg/kg/day at the end of a 13-week recovery period were 0.08 and 0.15 $\mu\text{g/g}$ (Butenhoff et al. 2004b).

Rat. Ylinen et al. (1990) administered newly weaned Wistar rats (18/gender/group) doses of 3, 10, and 30 mg/kg/day PFOA by gavage for 28 days. At necropsy, serum was collected as well as brain, liver, kidney, lung, spleen, ovary, testis, and adipose tissue. The concentration of PFOA in the serum and tissues was determined with capillary gas chromatography equipped with a flame ionization detector (FID). A mass spectrometer was used in the selected ion monitoring mode when the PFOA concentration was below the LOQ of the FID (1 $\mu\text{g/ml}$).

The concentration of PFOA in the serum and tissues following 28 days of administration is presented in Table 2-4. PFOA was not detected in the adipose tissue. The concentrations of PFOA in the serum and tissues were much higher in males than in females. In the males, the levels of PFOA in the serum were generally lower in the 30 mg/kg/day dose group than in the 10 mg/kg/day dose group due to increased urinary elimination in the 30 mg/kg/day group. The tissue levels were similar for the 10 and 30 mg/kg/day doses. In females, there was a dose-related increase in tissue levels while the serum levels were comparable for the 10 and 30 mg/kg/day dose groups. Among solid tissues, the liver had the highest tissue concentration followed by the testis, spleen, lung, kidney, and brain, respectively. In females, the concentration in the kidneys exceeded that in the liver for the 10 and 30 mg/kg/day doses but not at the lowest dose. Ovary and spleen tissue had similar concentrations followed by lower levels in the lung and brain.

Table 2-4. Tissue Distribution of PFOA in Wistar Rats After 28 Days of Treatment

Tissue	Dose (Males ^a) mg/kg/day			Dose (Females ^a) mg/kg/day		
	3	10	30	3	10	30
Serum	48.6 ± 10.3	87.27 ± 20.09	51.65 ± 1.47	2.4 ^b	12.47 ± 4.07	13.92 ± 6.06
Liver	39.9 ± 7.25	51.71 ± 11.18	49.77 ± 10.76	1.81 ± 0.49	3.45 ± 1.36	6.64 ± 2.64
Kidney	1.55 ± 0.71	40.56 ± 14.94	39.81 ± 17.67	0.06 ± 0.02	7.36 ± 3.19	12.54 ± 8.24
Spleen	4.75 ± 1.66	7.59 ± 3.5	4.1 ± 1.57	0.15 ± 0.04	0.38 ± 0.17	1.59 ± 0.49
Lung	2.95 ± 0.54	22.58 ± 4.59	23.71 ± 5.42	0.24 ^b	0.22 ± 0.15	0.75 ± 0.26
Brain	0.398 ± 0.144	1.464 ± 0.211	0.71 ± 0.32	< LOQ ^c	0.029 ± 0.019	0.044 ± 0.018
Ovary				< LOQ	0.41 ± 0.27	1.16 ± 0.58
Testis	6.24 ± 2.04	9.35 ± 4.02	7.22 ± 3.17			

Source: Ylinen et al. 1990

Notes:

^a n = 6, mean ± SD, µg/ml tissue.

^b n = 3, no SD.

^c Below LOQ of 1µg/mL

Kemper (2003) examined the distribution of PFOA in tissues of male and female Sprague-Dawley rats following administration by gavage. Rats were administered 1, 5, and 25 mg/kg ¹⁴C-PFOA by oral gavage. Tissue concentrations were determined at the time of maximum plasma concentration (T_{max}) and at the time that plasma concentration had fallen to one half the maximum ($T_{max/2}$). Values for T_{max} and $T_{max/2}$ for male and female rats were determined from PK experiments. In those experiments, plasma was collected over the course of several days and PFOA concentration was analyzed. Noncompartmental PK models were applied to identify T_{max} and elimination half-time ($T_{1/2}$) from the data. The $T_{max/2}$ was calculated as the time (hr) for the maximum plasma concentration plus the elimination half-time (hr) ($T_{max} + T_{1/2}$). In some cases, elimination could occur in a rapid phase followed by a slower elimination phase. For cases in which biphasic elimination was evident, the rapid phase $T_{1/2}$ was used for calculation of $T_{max/2}$.

Tissues from male rats were collected at 10.5 hours (T_{max}) and 171 hours ($T_{max/2}$) after dosing. Tissues from female rats were collected at 1.25 hours (T_{max}) and 4 hours ($T_{max/2}$) after dosing. The results are summarized in Table 2-5 for males and Table 2-6 for females. Liver, blood, skin, muscle, bone, G.I. tract, and fat were the primary tissues for distribution of ¹⁴C-PFOA. In males, the fraction of the dose found in the liver increased between T_{max} and $T_{max/2}$, but remained constant or decreased in other tissues. In females, the fraction of the dose present in all tissues remained constant or decreased between T_{max} and $T_{max/2}$. Liver-to-blood concentration ratios for ¹⁴C at T_{max} in males were greater than 1 and increased between T_{max} and $T_{max/2}$. In females distribution levels in blood were between 1 and 2 at all dose levels and remained relatively constant between T_{max} and $T_{max/2}$. In males, the blood distributions levels were tenfold or higher than kidney levels at T_{max} and declined slightly at $T_{max/2}$.

Examination of the residuals from the administered PFOA in the male tissues at $T_{max/2}$ (171 hours) indicate that 40–60% of the dosed PFOA retained was present in the liver, blood, skin, and muscle tissues in decreasing amounts (Table 2-5). In males, about 1% of the label was present in the gastrointestinal tissues and contents at $T_{max/2}$, while the value for females was about 10%. However, the samples were collected at 1.25 and 4 hours in females and 10.5 and 171 hours in males, providing more time for absorption in the males.

Table 2-5. Distribution of PFOA in Male Sprague-Dawley Rats After Oral Exposure Dose

Tissue	1 mg/kg		5 mg/kg		25 mg/kg	
	% at T _{max}	% at T _{max/2}	% at T _{max}	% at T _{max/2}	% at T _{max}	% at T _{max/2}
Prostate	0.083 ± 0.039	0.030 ± 0.002	0.071 ± 0.045	0.057 ± 0.020	0.067 ± 0.018	0.028 ± 0.012
Skin ^a	14.77 ± 2.135	6.061 ± 0.274	15.565 ± 0.899	7.233 ± 0.430	13.836 ± 0.969	5.419 ± 0.237
Blood ^a	22.148 ± 0.692	8.232 ± 1.218	24.919 ± 1.942	11.140 ± 0.624	22.905 ± 1.177	7.904 ± 1.032
Brain	0.071 ± 0.018	0.022 ± 0.002	0.051 ± 0.021	0.023 ± 0.008	0.063 ± 0.007	0.019 ± 0.002
Fat ^a	2.281 ± 0.467	0.593 ± 0.136	2.815 ± 0.225	0.916 ± 0.205	2.153 ± 0.430	0.628 ± 0.110
Heart	0.451 ± 0.119	0.195 ± 0.024	0.443 ± 0.037	0.252 ± 0.030	0.461 ± 0.053	0.164 ± 0.032
Lungs	0.74 ± 0.147	0.341 ± 0.043	0.593 ± 0.376	0.344 ± 0.194	0.863 ± 0.103	0.303 ± 0.057
Spleen	0.086 ± 0.011	0.045 ± 0.006	0.096 ± 0.017	0.060 ± 0.007	0.106 ± 0.015	0.042 ± 0.005
Liver	21.708 ± 5.627	32.627 ± 3.601	18.750 ± 2.434	25.231 ± 1.289	17.528 ± 0.900	20.145 ± 3.098
Kidney	1.949 ± 0.402	1.14 ± 0.215	2.170 ± 0.354	1.212 ± 0.115	2.293 ± 0.286	1.003 ± 0.122
G.I. tract	2.930 ± 0.929	0.980 ± 0.300	2.508 ± 0.713	1.052 ± 0.202	2.784 ± 0.608	0.808 ± 0.189
G.I. contents	2.083 ± 0.625	0.239 ± 0.025	2.632 ± 0.934	0.270 ± 0.028	4.186 ± 1.349	0.210 ± 0.084
Thyroid	0.008 ± 0.005	0.004 ± 0.003	0.011 ± 0.006	0.004 ± 0.002	0.009 ± 0.002	0.005 ± 0.001
Thymus	0.085 ± 0.008	0.051 ± 0.018	0.085 ± 0.012	0.053 ± 0.003	0.120 ± 0.025	0.045 ± 0.010
Testes	0.755 ± 0.079	0.356 ± 0.037	0.693 ± 0.180	0.372 ± 0.062	0.623 ± 0.098	0.224 ± 0.031
Adrenals	0.019 ± 0.004	0.010 ± 0.001	0.022 ± 0.004	0.009 ± 0.001	0.026 ± 0.004	0.009 ± 0.003
Muscle ^a	12.025 ± 0.648	4.984 ± 0.745	13.565 ± 0.576	6.429 ± 0.648	12.855 ± 0.841	4.253 ± 0.358
Bone ^a	3.273 ± 0.538	1.120 ± 0.094	3.047 ± 0.544	1.375 ± 0.169	3.062 ± 0.438	0.906 ± 0.100
Total ^b	85.465 ± 6.426	57.026 ± 3.379	88.033 ± 1.420	56.031 ± 1.025	83.937 ± 3.680	42.112 ± 4.740

Source: Kemper 2003

Notes: Percent of dose recovered at T_{max} and T_{max/2} in tissues.

^a Percent recovery scaled to whole animal assuming the following: skin=19%, whole blood=7.4%, fat=7%, muscle=40.4%, bone=7.3% of body weight.

^b Totals are calculated from individual animal data.

In the female tissues at T_{max/2} (4 hours), approximately 30% of the dosed PFOA retained was present in the liver, blood, kidney, muscle, and skin tissues in decreasing amounts (Table 2-6). About 14% of the administered dose remained in the gastrointestinal tissues and contents. Based on the timing of the measurements and the results, females appear to absorb and excrete PFOA more rapidly than males.

Lau et al. (2006) studied PFOA's toxicokinetic properties in rats as part of a larger study. The authors gavage-dosed adult male and female Sprague-Dawley rats (n = 8) with 10 mg/kg for 20 days and sacrificed them 24 hours after the last treatment. After 20 days of treatment, male rats had serum PFOA levels of 111 µg/mL compared to 0.69 µg/mL in female rats.

Martin et al. (2007) administered 20 mg PFOA/kg to adult male Sprague-Dawley rats (n = 4 or 5) for 1, 3, and 5 days by oral gavage and determined the liver and serum levels of PFOA. Blood was collected via cardiac puncture and PFOA concentration was determined by high-performance liquid chromatography-electrospray tandem mass spectrometry (LC-MS/MS). The mean liver PFOA concentration was 92 ± 6, 250 ± 32, and 243 ± 23 µg/g after 1, 3, and 5 daily doses of 20 mg PFOA/kg/day, respectively. The mean serum concentration was 245 ± 41 µg/mL after 3 daily doses of 20 mg PFOA/kg/day. Serum PFOA concentration was not determined after 1 day and 5 days of dosing due to sample availability.

Table 2-6. Distribution of PFOA in Female Sprague-Dawley Rats after Oral Exposure Dose

Tissue	1 mg/kg		5 mg/kg		25 mg/kg	
	% at T _{max}	% at T _{max/2}	% at T _{max}	% at T _{max/2}	% at T _{max}	% at T _{max/2}
Skin ^a	0.434 ± 0.162	0.403 ± 0.096	0.624 ± 0.142	0.307 ± 0.121	0.380 ± 0.166	0.415 ± 0.175
Blood ^a	5.740 ± 1.507	4.438 ± 1.625	8.089 ± 2.080	5.411 ± 1.466	7.158 ± 2.232	6.407 ± 1.406
Brain	0.037 ± 0.009	0.047 ± 0.008	0.066 ± 0.019	0.045 ± 0.010	0.058 ± 0.008	0.058 ± 0.018
Fat ^a	0.134 ± 0.032	0.164 ± 0.079	0.220 ± 0.111	0.110 ± 0.069	0.147 ± 0.053	0.148 ± 0.065
Heart	0.198 ± 0.079	0.253 ± 0.055	0.388 ± 0.057	0.236 ± 0.051	0.317 ± 0.035	0.287 ± 0.069
Lungs	0.454 ± 0.148	0.546 ± 0.082	0.827 ± 0.102	0.570 ± 0.179	0.678 ± 0.067	0.775 ± 0.204
Spleen	0.063 ± 0.027	0.058 ± 0.006	0.101 ± 0.021	0.060 ± 0.012	0.091 ± 0.007	0.070 ± 0.002
Liver	7.060 ± 1.266	6.817 ± 1.537	11.190 ± 2.192	7.176 ± 0.982	10.538 ± 1.723	9.080 ± 0.895
Kidney	3.288 ± 0.948	2.769 ± 0.784	4.293 ± 0.771	2.685 ± 0.736	5.867 ± 0.946	4.749 ± 0.393
G.I. tract	10.699 ± 9.066	8.462 ± 6.519	7.142 ± 2.594	8.255 ± 8.967	6.923 ± 1.846	3.547 ± 1.306
G.I. contents	21.956 ± 13.48	3.891 ± 2.395	2.896 ± 2.305	5.601 ± 6.165	2.491 ± 1.548	1.121 ± 1.010
Thyroid	0.010 ± 0.003	0.016 ± 0.021	0.008 ± 0.002	0.006 ± 0.002	0.009 ± 0.003	0.007 ± 0.002
Thymus	0.052 ± 0.017	0.058 ± 0.024	0.105 ± 0.030	0.068 ± 0.021	0.091 ± 0.032	0.077 ± 0.020
Ovaries	0.047 ± 0.019	0.048 ± 0.006	0.071 ± 0.012	0.041 ± 0.012	0.071 ± 0.012	0.070 ± 0.012
Adrenals	0.014 ± 0.005	0.018 ± 0.004	0.026 ± 0.005	0.015 ± 0.004	0.031 ± 0.005	0.021 ± 0.001
Muscle ^a	0.170 ± 0.051	0.258 ± 0.089	0.325 ± 0.010	0.229 ± 0.031	0.441 ± 0.116	0.304 ± 0.099
Uterus	0.243 ± 0.091	0.374 ± 0.247	0.354 ± 0.046	0.247 ± 0.068	0.358 ± 0.124	0.365 ± 0.029
Bone ^a	0.101 ± 0.017	0.153 ± 0.052	0.174 ± 0.057	0.142 ± 0.078	0.157 ± 0.072	0.181 ± 0.090
Total ^b	50.698 ± 16.48	28.772 ± 10.98	36.897 ± 3.187	31.201 ± 12.63	35.803 ± 2.554	27.680 ± 2.569

Source: Kemper 2003

Notes: Percent of dose recovered at T_{max} and T_{max/2} in tissues.

^a Percent recovery scaled to whole animal assuming the following: skin=19%, whole blood=7.4%, fat=7%, muscle=40.4%, bone=7.3% of body weight.

^b Totals are calculated from individual animal data.

Mouse. Lau et al. (2006) gavaged adult male and female CD-1 mice (5–7/group) with 20 mg/kg for 7 and 17 days. The animals were sacrificed 24 hours after the last treatment. After 7 days of treatment, male mice had serum PFOA levels of 181 µg/mL and females had levels of 178 µg/mL. After 17 days of treatment, male mice had serum PFOA levels of 199 µg/mL and females had levels of 171 µg/mL. These data suggest that the gender difference observed by Lau et al (2006) in rats was not seen in the mice under the conditions of this study.

As part of a physiologically based pharmacokinetic (PBPK) modeling exercise, Lou et al. (2009) administered single doses of 1 and 10 mg/kg to groups of three male and three female CD-1 mice. The mice were sacrificed for analysis of plasma, liver, and kidney tissues after 4, 8, and 12 hours and at 1, 3, 6, 9, 13, 20, 27, 34, and 48 days after dosing. This study was repeated for a second analysis that extended the sacrifice times to 55, 62, 70, and 80 days.

Measures of PFOA in serum were presented graphically and indicate that the order of magnitude difference between the doses led to a comparable order of magnitude difference in serum concentrations for both males and females across the 80-day observation period. [The study procedures indicated that *serum* was collected and analyzed, but the graphic presentation described the values as *plasma* values. Contact with one of the authors confirmed that the values should have been listed as *serum* rather than *plasma*.] The peak serum concentrations were

10 and 100 mg/L for the 1 and 10 mg/kg/day doses, respectively. Declines in serum concentrations for females over time were roughly parallel reaching concentrations of about 2 mg/L and <0.2 mg/L for the high and low doses, respectively, at the end of 80 days. Peak serum concentrations were slightly lower in the males (~8 and 80 mg/L) than in the females, and final serum concentrations were higher in the males (~0.5 and 8 mg/L). Liver and kidney concentrations also were higher in males than in females for each of the two doses. These data suggest a longer half-life in males than in females.

Lou et al. (2009) also collected serum data for up to 28 days after administration of a 60-mg/kg dose to groups of three female mice. Based on the graphic presentation of the data, the 60-mg/kg dose was cleared from the serum much more rapidly than the 1- and 10-mg/kg doses. For example, a serum concentration of about 0.4 mg/L was reached in about 28 days for the 60-mg/kg dose, 61 days for the 10-mg/kg dose, and 70 days for the 1-mg/kg dose (values estimated from Figure 3 in Lou et al. [2009]). No measurements were made for liver or kidney in the high-dose animals.

In the final experimental portion of the study, Lou et al. (2009) exposed groups of five female CD-1 mice to 20 mg/kg/day for 17 days. Serum samples were collected 24 hours after the final dose and analyzed for PFOA. The mean serum concentration was 130 ± 23 mg/L, which is comparable to that of 171 $\mu\text{g/mL}$ reported by Lau et al. (2006).

Minata et al. (2010) orally administered 0, 12.5, 25, and 50 micromole per kilogram ($\mu\text{mol/kg}$) PFOA (~0, 5.4, 10.8, and 21.6 mg/kg PFOA) to groups of male wild-type 129S4/SvImJ mice (n = 39) and PPAR α -null 129S4/SvJae-Ppara^{tm1Gonz/J} mice (n = 40) for 4 weeks. Blood, liver, and bile were collected for determination of PFOA concentration at the end of 4 weeks, as shown in Table 2-7. The PFOA concentration in whole blood and the liver were similar between wild-type and PPAR α -null mice at the same dose level and appeared to increase in proportion to dose. In bile, PFOA concentration in wild-type mice increased by a factor of 13.8 from 12.5 to 25 $\mu\text{mol/kg}$ and by a factor of 2.8 from 25 to 50 $\mu\text{mol/kg}$. In the bile of PPAR α -null mice, PFOA concentration increased by a factor of 3.2 from 12.5 to 25 $\mu\text{mol/kg}$ and by a factor of 19.5 from 25 to 50 $\mu\text{mol/kg}$. The data suggested saturation of PFOA transport from the liver to bile ducts in wild-type mice, but not PPAR α -null mice. This may indicate that PPAR α plays a role in the clearance of PFOA.

Table 2-7. PFOA Concentrations in Wild-type and PPAR α -null Mice ($\mu\text{g/mL}$)

Dose $\mu\text{mol/kg}$	Whole Blood		Bile		Liver	
	Wild-type	PPAR α -null	Wild-type	PPAR α -null	Wild-type	PPAR α -null
0	ND	ND	ND	ND	ND	ND
12.5	20.6 \pm 2.4	19.3 \pm 2.2	56.8 \pm 26.9	19.6 \pm 2.2	181.2 \pm 6.3	172.3 \pm 8.9
25	46.9 \pm 3.2	36.4 \pm 2.7*	784 \pm 137.6	62.9 \pm 16.7**	198.8 \pm 15.4	218.3 \pm 14.5
50	64.2 \pm 6.5	71.2 \pm 8.0	2174 \pm 322.4	383 \pm 109.9**	211.6 \pm 13.3	239.7 \pm 25.0

Source: Minata et al. 2010

Notes: Mean \pm SD; ND= not detected (< 0.001 $\mu\text{g/mL}$); * p < 0.05; ** p < 0.01

Tissue Transporters. As identified earlier, protein transporters from a number of families play a role in the tissue uptake of orally ingested PFOA. The transporters are located at the interface between the serum and the liver, kidneys, lungs, heart, brain, testes, ovaries, placenta, and uterus (Klaassen and Aleksunes 2010). The liver is an important uptake site for PFOA. OATPs and MRPs, at least one OAT, and the sodium-taurocholate cotransporting polypeptide (NTCP), a

hepatic bile uptake transporter, have been identified at the interface of the liver with the portal blood and/or the canalicular membranes within the liver (Kim 2003; Kusuhara and Sugiyama 2009; Zaïr et al. 2008).

The impact of PFOA on several membrane transporter systems linked to biliary transport was studied by Maher et al. (2008) as part of a more detailed study of perfluorodecanoic acid (PFDA). A dose of 80 mg/kg by intraperitoneal (i.p.) injection (propylene glycol: water vehicle) was found to significantly increase ($p < 0.05$) the expression of MRP3 and MRP4 in the livers of C57BL/6 mice 2 days after treatment as reflected in quantification of their deoxyribonucleic acid (DNA) transcripts. MRP3 and MRP4 are believed to protect the liver from accumulation of bile acids, bilirubin, and potentially toxic exogenous substances by promoting their excretion in bile. There were significant increases in serum bilirubin and bile acids after PFDA exposure, signifying increased export. Conversely, there were significant decreases ($p < 0.05$) in the protein levels for OATP1a1, OATP1a4, and OATP1b2 as determined by Western Blot analysis and messenger ribonucleic acid (mRNA) measurements following exposure to 40 mg PFOA/kg (Cheng and Klaassen 2008). There was no significant impact on NTCP protein or the serum levels of bile acids. The OATPs are transporters responsible for the uptake of bile acids and other hydrophobic substances such as steroid conjugates, ecosinoids, and thyroid hormones into the liver.

These studies, all by the same laboratory, were carried out at high, single-dose exposures, which limit their value in extrapolating to low- and repeat-dose scenarios. The results suggest a decrease in the uptake of favored substrates into the liver and an increase in removal of favored substrates from the liver via bile. Upregulation of MRP3 and MRP4, coupled with decreased OATp levels, could be beneficial due to increased biliary excretion of bile acids, bilirubin, and conjugated metabolites of toxic chemicals, including PFOA. Based on the results with the more extensive evaluation of PFDA including mouse strains null for several receptors (PPAR α , CAR, PXR, and FXR), the authors concluded that the changes in receptor proteins were primarily linked to activation of PPAR α .

Impact of Developmental Age. Han (2003) administered groups of 4–8-week-old Sprague-Dawley rats (10 per gender per age) a single dose of 10 mg/kg/day PFOA by oral gavage. Blood samples were collected 24 hours after dosing and the plasma concentration of PFOA was measured by high-performance liquid chromatography mass spectrometry (HPLC/MS). In the 4-week-old rats, the concentration of plasma PFOA was approximately 2.7 times higher in males than in the females (Table 2-8). In the 5- and 6-week-old female rats, the plasma PFOA concentrations were about twofold lower than in the 4-week-old rats. However, in the 5-week-old males, the concentration of plasma PFOA was about fivefold higher than in the 4-week-old group, suggesting a developmental change in excretion rate. Plasma concentrations did not differ appreciably among 5-, 6-, 7-, and 8-week-old rats within each gender but did differ between genders. In fact, PFOA plasma concentrations were 35–65-fold higher in males than in females at every age except at 4 weeks. Thus, it appears that maturation of the transport features responsible for the gender difference in elimination occurs between the ages of 4 and 5 weeks in the rat.

Table 2-8. Plasma PFOA Concentrations (µg/ml) in Postweaning Sprague-Dawley Rats

Age (weeks)	Males	Females
4	7.32 ± 1.01 ^a	2.68 ± 0.64
5	39.24 ± 3.89	1.13 ± 0.46
6	43.19 ± 3.79	1.18 ± 0.52
7	37.12 ± 4.07	0.57 ± 0.29
8	38.55 ± 5.44	0.81 ± 0.27

Source: Han 2003

Notes:

^a Mean ± SD; samples from 10 animals/gender/group

Hinderliter (2004) and Hinderliter et al. (2006a) continued the investigation of the relationship between age and plasma PFOA in male and female Sprague-Dawley rats. Immature rats at 3, 4, and 5 weeks of age were administered PFOA via oral gavage at a single dose of 10 or 30 mg/kg. Rats were not fasted prior to dosing. Two hours after dosing, five rats per gender per age group and dose group were sacrificed and blood samples were collected. The remaining five rats per gender per age and dose group were placed in metabolism cages for 24-hour urine collection. These rats were sacrificed at 24 hours and blood samples were collected.

In the male rats, plasma PFOA concentrations for either the 10- or 30-mg/kg dosage groups did not differ significantly by sample time (at 2 and 24 hours) or by animal age (3, 4, and 5 weeks), except at 2 hours for the 5-week-old group ($p < 0.01$), which showed the lowest PFOA level (Table 2-9). PFOA plasma concentrations following a 30-mg/kg dose were 2–3 times higher than those following a 10-mg/kg dose. These data do not demonstrate a difference between the 5-week-old rats and the younger 3- and 4-week-old groups at 24 hours after dosing, and thus do not support the observations from the Han study (2003).

Table 2-9. Plasma PFOA Concentrations in Male Rats

Age (weeks)	Dose (mg/kg)	Plasma PFOA (µg/ml)			
		2 Hours Post-Dose		24 Hours Post-Dose	
		Mean	SD	Mean	SD
3	10	41.87	4.01	34.22	7.89
4	10	39.92	4.45	42.94	5.33
5	10	26.32*	6.89	40.60	3.69
3	30	120.65	12.78	74.16	18.23
4	30	117.40	18.10	100.81	13.18
5	30	65.66*	15.53	113.86	23.36

Source: Hinderliter 2004

Note: *Statistically significantly different by sample time and animal age ($p < 0.01$).

In the female rats, plasma PFOA concentrations were significantly lower in the 5-week-old group than in the 3- or 4-week-old groups at the 24-hour time period for both doses and for the 30-mg/kg dose group at 2 hours (Table 2-10). Plasma PFOA concentrations following a 30-mg/kg dose were approximately one and one half to four times higher than those observed following a 10-mg/kg dose.

At 24 hours post-dose, plasma PFOA levels in the female rats were significantly lower than the plasma PFOA levels in male rats, especially at 5 weeks of age. The data for the 5-week-old female rats compared to the 3- and 4-week-old groups at 24 hours are consistent with the Han (2003) data

in that they demonstrate a decline in plasma levels compared to their earlier measurements. Thus, the developmental change is one that appears to be unique to the female rat.

Table 2-10. Plasma PFOA Concentrations in Female Rats

Age (weeks)	Dose (mg/kg)	Plasma PFOA (µg/ml)			
		2 Hours Post-Dose		24 Hours Post-Dose	
		Mean	SD	Mean	SD
3	10	37.87	5.77	13.55 ^b	3.83
4	10	29.88	12.15	18.98 ^b	7.01
5	10	33.23	7.41	1.36 ^{a, b}	0.87
3	30	84.86	10.51	51.43 ^b	13.61
4	30	80.67	14.10	28.01 ^b	9.90
5	30	56.90 ^a	29.66	3.42 ^{a, b}	1.95

Source: Hinderliter 2004

Notes:

^a Statistically significantly different from the 3- and 4-week values ($p < 0.01$).

^b Statistically significantly different from 2-hour values ($p < 0.01$).

The data demonstrate that both dose and gender influence plasma levels. Post-dosing clearance (CL) is slow for both doses at 2 and 24 hours in males and females at postnatal weeks 3 and 4. At 5 weeks, however, the plasma levels after 24 hours are greater than those at 2 hours in males. In females, for the high dose at 2 hours, plasma levels are similar to those in males, while at 24 hours they are only 3% of the value for males. This suggests that uptake from the intestines is similar while the rate of excretion at 5 weeks and beyond is considerably greater for female rats than males. They are comparable for postnatal weeks 3 and 4.

In a supplemental study to determine the effect of fasting (Hinderliter [2004] and Hinderliter et al. [2006a]), 4-week-old rats, 4 rats per gender, were administered 10 mg/kg PFOA via oral gavage. Animals (two per gender) were fasted overnight for 12 hours before dosing with PFOA. All the rats were sacrificed at 24 hours post dosing and blood was collected for analysis of PFOA in plasma. Plasma PFOA concentrations in male rats were 64.95 and 30.00 µg/ml for the fasted and nonfasted animals, respectively. Plasma PFOA concentrations in the female rats were 68.16 and 26.54 µg/ml for the fasted and nonfasted animals, respectively. Given the consistency in the 4-week-old rat plasma PFOA concentrations, the authors concluded that age-dependent changes in female PFOA elimination are observable between 3 and 5 weeks of age. PFOA uptake was greater in the fasted animals than the fed animals, suggesting competition for uptake in the presence of food components that share common transporters and/or decreased contact of PFOA with the intestinal epithelium in the presence of dietary materials.

Distribution during Pregnancy and Lactation

Humans. T. Zhang et al. (2013) recruited pregnant females for a study to examine the distribution of PFOA between maternal blood, cord blood, the placenta, and amniotic fluid. Thirty-two females from Tianjin, China, volunteered to take part in the study. Samples were collected at time of delivery. Maternal ages ranged from 21 to 39 years, gestation periods ranged from 35 to 37 weeks. It was the first child for 26 of the females and a second child for 6. The study yielded 31 maternal whole blood samples, 30 cord blood samples, 29 amniotic fluid samples, and 29 placentas. The maternal blood contained variable levels of 10 PFASs, eight acids, and two sulfonates. The mean maternal blood concentration was highest for PFOS

(14.6 ng/mL) followed by PFOA (3.35 ng/mL). In both cases, the mean was greater than the median, indicating a distribution skewed toward the higher concentrations.

PFOA was found in all fluids/tissues sampled. PFOA was transferred to the amniotic fluid to a greater extent than PFOS, based on their relative proportions in the maternal blood and cord blood. Compared to the mean PFOA blood levels in the pregnant females, the mean levels in the cord blood, placenta, and amniotic fluid were 47%, 59%, and 1.3%, respectively, of those in the mother's blood. The correlation coefficients between the maternal PFOA blood levels and placenta, cord blood, and amniotic fluid levels were good (0.7–0.9) and the relationships statistically significant ($p < 0.001$).

Rat. An oral two-generation reproductive toxicity study of PFOA in rats was conducted (Butenhoff et al. 2004a). Five groups of rats (30 gender/group) were administered PFOA by gavage at doses of 0, 1, 3, 10, and 30 mg/kg/day. At scheduled sacrifice, after completion of the cohabitation period in F0 male rats and on lactation day (LD) 22 in F0 female rats, blood samples (3/gender/group-control; 10/gender/group-treated) were collected from animals dosed with 0, 10, and 30 mg/kg for analysis of PFOA. Serum analysis for the F0 generation males in the control, 10-, and 30-mg/kg/day groups sampled at the end of cohabitation showed that PFOA was present in all samples tested, including controls. Control males had an average concentration of 0.0344 ± 0.0148 $\mu\text{g/ml}$ PFOA. Levels of PFOA were similar in the two male dose groups; treated males had 51.1 ± 9.30 and 45.3 ± 12.6 $\mu\text{g/ml}$, respectively, for the 10- and 30-mg/kg/day dose groups. In the F0 female controls, serum PFOA was below LOQ (0.00528 $\mu\text{g/ml}$). Levels of PFOA found in female sera increased between the two dose groups; treated females had an average concentration of 0.37 ± 0.0805 and 1.02 ± 0.425 $\mu\text{g/ml}$, respectively, for the 10- and 30-mg/kg/day dose groups.

PFOA levels during gestation and lactation were studied by Hinderliter et al. (2005) and Mylchreest (2003). Groups of 20 pregnant Sprague-Dawley rats were dosed with 0, 3, 10, and 30 mg/kg/day of PFOA during days 4–10, 4–15, and 4–21 of gestation, or from gestation day (GD) 4 to LD 21. Maternal blood samples were collected at 2 hours \pm 30 minutes (mins) post-dose on a daily basis. Clinical observations and body weights were recorded daily. Five animals per dose group were sacrificed at specific time periods to harvest the conceptus and/or placenta and amniotic fluid. On GD 10, only embryos were recovered, and on GDs 15 and 21, the placentas, amniotic fluid, and embryos/fetuses were collected.

The remaining five rats per group were allowed to deliver their pups. On LDs 0, 3, 7, 14, and 21, the pups were counted, weighed (genders separate), and examined for abnormal appearance and behavior. Randomly selected pups were sacrificed and blood samples were collected. On LDs 3, 7, 14, and 21, the dams were anesthetized and milk and blood samples were collected; dams were removed from their litters 1–2 hours prior to collection.

Plasma, milk, amniotic fluid extract, and tissue homogenate (placenta, embryo, and fetus) supernatants were analyzed for PFOA concentrations by HPLC/MS. Maternal PFOA plasma levels during gestation and lactation are presented in Table 2-11. Maternal plasma levels at 2 hours post-dosing (approximately the time of peak blood levels following a gavage dose) were fairly similar during the course of the study with a mean level of 11.2, 26.8, and 66.6 $\mu\text{g/ml}$ in the 3-, 10-, and 30-mg/kg/day groups, respectively; PFOA levels in the control group were below the LOQ (0.05 $\mu\text{g/ml}$).

Table 2-11. Maternal Plasma PFOA Levels (µg/ml) in Rats During Gestation and Lactation

Exposure Period	Sample Time	Dose		
		3 mg/kg/day	10 mg/kg/day	30 mg/kg/day
GD 4 - GD 10	GD 10 plasma	8.53 ± 1.06	23.32 ± 2.15	70.49 ± 8.94
GD 4 - GD 15	GD 15 plasma	15.92 ± 12.96	29.40 ± 14.19	79.55 ± 3.11
GD 4 - GD 21	GD 21 plasma	14.04 ± 2.27	34.20 ± 6.68	76.36 ± 14.76
GD 4 - LD 3	LD 3 plasma	11.01 ± 2.11	22.47 ± 2.74	54.39 ± 17.86
GD 4 - LD 7	LD 7 plasma	10.09 ± 2.90	25.83 ± 2.07	66.91 ± 11.82
GD 4 - LD 14	LD 14 plasma	9.69 ± 0.92	23.79 ± 2,81	54.65 ± 11.63
GD 4 - LD 21	LD 21 plasma	9.04 ± 1.01	28.84 ± 5.15	64.13 ± 1.45
NA	Average plasma	11.19 ± 2.76	26.84 ± 4.21	66.64 ± 9.80

Source: Hinderliter et al. 2005; Mylchreest 2003

Notes: Mean ± SD; samples were from five dams/group/time point and were collected 2 hours post-dosing.

PFOA levels in the placenta, amniotic fluid, and embryo/fetus are presented in Table 2-12. The levels of PFOA in the placenta on GD 21 were approximately twice the levels observed on GD 15, and the levels of PFOA in the amniotic fluid were approximately four times higher on GD 21 than on GD 15. The concentration of PFOA in the embryo/fetus was highest in the GD 10 embryo and lowest in the GD 15 embryo; PFOA levels in the GD 21 fetus were intermediate.

Table 2-12. Placenta, Amniotic Fluid, and Embryo/Fetus PFOA Concentrations in Rats (µg/ml)

Exposure Period	Tissue	Dose		
		3 mg/kg/day	10 mg/kg/day	30 mg/kg/day
GD 4—GD 10	GD 10—embryo	1.40 ± 0.30	3.33 ± 0.81	12.49 ± 3.50
GD 4—GD 15	GD 15—placenta	2.22 ± 1.79	5.10 ± 1.70	13.22 ± 1.03
	—amniotic fluid	0.60 ± 0.69	0.70 ± 0.15	1.70 ± 0.91
	—embryo	0.24 ± 0.19	0.53 ± 0.18	1.24 ± 0.22
GD 4—GD 21	GD 21—placenta	3.55 ± 0.57	9.37 ± 1.76	24.37 ± 4.13
	—amniotic fluid	1.50 ± 0.32	3.76 ± 0.81	8.13 ± 0.86
	—fetus	1.27 ± 0.26	2.61 ± 0.37	8.77 ± 2.36

Source: Hinderliter et al. 2005; Mylchreest 2003

Note: Mean ± SD; samples were pooled by litter and were collected 2 hours post-dosing.

The concentrations of PFOA in the plasma of the GD 21 fetus were approximately half the levels observed in the maternal plasma (Table 2-11). The values were about twice as high in the dams as in the pups with mean values of 14.04, 34.20, and 76.36 µg/ml, respectively, in the 3-, 10-, and 30-mg/kg/day groups for the dams and 5.88, 14.48, and 33.11 µg/ml, respectively, for the pups. Pup plasma levels decreased between birth and LD 7 (Table 2-13) and were, thereafter, similar to the levels observed in the milk (Table 2-14). The pups were not separated by gender.

The concentration of PFOA in the milk also was fairly similar throughout lactation and was approximately one-tenth of the PFOA levels in the maternal plasma (see Table 2-11); the mean values for maternal milk were 1.1, 2.8, and 6.2 µg/ml in the 3-, 10-, and 30-mg/kg/day groups, respectively (Table 2-14).

Table 2-13. Fetus/Pup PFOA Concentration (µg/ml) in Rats During Gestation and Lactation

Exposure Period	Tissue	Dose		
		3 mg/kg/day	10 mg/kg/day	30 mg/kg/day
GD 4–GD 21	GD21—fetal plasma	5.88 ± 0.69	14.48 ± 1.51	33.11 ± 4.64
GD 4–LD 3	LD 3—pup plasma	2.89 ± 0.70	5.94 ± 1.44	11.96 ± 1.66
GD 4–LD 7	LD 7—pup plasma	0.65 ± 0.20	2.77 ± 0.58	4.92 ± 1.28
GD 4–LD 14	LD 14—pup plasma	0.77 ± 0.10	2.22 ± 0.38	4.91 ± 1.12
GD 4–LD 21	LD 21—pup plasma	1.28 ± 0.72	3.25 ± 0.52	7.36 ± 2.17

Source: Hinderliter et al. 2005; Mylchreest 2003

Note: Mean ± SD; samples were pooled by litter and were collected 2 hours post-dosing.

Table 2-14. PFOA Levels (µg/ml) in Rats Maternal Milk During Lactation

Exposure Period	Sample Time	Dose		
		3 mg/kg/day	10 mg/kg/day	30 mg/kg/day
GD 4–LD 3	LD 3–milk	1.07 ± 0.26	2.03 ± 0.33	4.97 ± 1.20
GD 4–LD 7	LD 7–milk	0.94 ± 0.22	2.74 ± 0.91	5.76 ± 1.26
GD 4–LD 14	LD 14–milk	1.15 ± 0.06	3.45 ± 1.18	6.45 ± 1.38
GD 4–LD 21	LD 21–milk	1.13 ± 0.08	3.07 ± 0.51	7.48 ± 1.63
NA	Average milk	1.07 ± 0.09	2.82 ± 0.60	6.16 ± 1.06

Source: Hinderliter et al. 2005; Mylchreest 2003

Notes: Mean ± SD; samples were from 5 dams/group/time point and were collected 2 hours post-dosing.

Mouse. Fenton et al. (2009) orally dosed pregnant CD-1 mice (n = 25/group) with 0, 0.1, 1, and 5 mg PFOA/kg on GD 17. On GD 18, five dams/group were sacrificed and trunk blood, urine, amniotic fluid, and the fourth and fifth mammary glands were collected. One fetus/dam was euthanized and retained for whole-pup analysis. The remaining dams were allowed to litter. Biological samples as described above excluding amniotic fluid also were collected on postnatal days (PNDs) 1, 4, 8, and 18. As before, at each time-point, a single pup was euthanized and retained for whole-pup analysis. Blood from the remaining pups was collected and pooled. Milk was collected from dams on PNDs 2, 8, 11, and 18 following a 2-hour separation of the pups from the dam.

The concentration of PFOA in dam serum was approximately twice that detected in amniotic fluid (Table 2-15). Compared to the amniotic fluid, the concentration of PFOA in the fetuses was increased by 2.3-, 3.1-, and 2.7-fold at 0.1, 1, and 5 mg/kg, respectively. The highest concentration of PFOA was detected in the serum of nursing dams. In the dams, the concentration of PFOA in the serum exhibited a U-shaped response curve; the lowest serum concentration was observed at the time of peak lactation. Dam mammary tissue and milk PFOA concentrations showed a U-shaped response that mirrored that found in the dam's serum. The concentration of PFOA in pup's serum was significantly higher than PFOA concentration in dam's serum and appeared to decrease as the time for weaning approached. When pup PFOA concentration was calculated with consideration for pup body weight gain, PFOA body burden increased through the peak of lactation and began to decrease by PND 18, showing an inverse U-shaped response curve.

Table 2-15. PFOA Levels (ng/ml) in Mice During Gestation and Lactation in Selected Fluids and Tissues

Tissue	Day	Dose		
		0.1 mg/kg	1 mg/kg	5 mg/kg
Dam Serum	GD 18	143 ± 19	1697 ± 203	7897 ± 663
	PND 1	217.5 ± 35	1957.0 ± 84	9845.6 ± 1478
	PND 4	110.0 ± 12	1269.4 ± 235	6776.6 ± 561
	PND 8	46.7 ± 21	360.8 ± 98	1961.8 ± 414
	PND 18	123.3 ± 41	1035.2 ± 305	5156.5 ± 1201
Amniotic Fluid	GD 18	99.0 ± 28	865.3 ± 191	3203.8 ± 492
Dam Urine	GD 18	21.9 ± 8.6	104.9 ± 69.7	666.7 ± 169
	PND 1	7.7 ± 1.7	116.8 ± 64	492.3 ± 119
	PND 4	8.4 ± 6.4	53.5 ± 15	401.5 ± 117
	PND 8	0.8 ± 0.22	11.6 ± 6.2	40.1 ± 17
	PND 18	1.8 ± 1.1	18.7 ± 8.6	91.7 ± 49
Mammary Gland	GD 18	18.9 ± 1.9	307.2 ± 30.4	1429 ± 186
	PND 1	27.4 ± 6.8	343.8 ± 53	1933.5 ± 194
	PND 4	9.6 ± 8.4	239.2 ± 53	1461.8 ± 267
	PND 8	2.4 ± 3.8	71.7 ± 22	411.8 ± 78
	PND 18	17.1 ± 10	239.9 ± 76	1372.8 ± 240
Milk	PND 2	32.5 ± 12	716.7 ± 145	1236.6 ± 1370
	PND 8	11.6 ± 8.1	77.4 ± 19	245.1 ± 26
	PND 11	5.4 ± 1.0	42.3 ± 9.1	282.5 ± 162
	PND 18	43.5 ± 19	251.8 ± 147	909.8 ± 308
Whole Pup	GD 18	136.3 ± 15	1665.8 ± 213	6256.5 ± 751
	PND 1	150.9 ± 21	1606.9 ± 288	7134.5 ± 1097
	PND 4	91.8 ± 8.9	1183.2 ± 187	5071.4 ± 267
	PND 8	60.9 ± 16	729.0 ± 92	3118.5 ± 424
	PND 18	17.5 ± 11	251.9 ± 112	1391.5 ± 118
Pup Serum	PND 1	324.7 ± 36	3926.8 ± 480	16,286.4 ± 1372
	PND 4	267.6 ± 47	3020.8 ± 223	11,925.2 ± 1077
	PND 8	260.2 ± 56	2548.2 ± 245	9215.8 ± 594
	PND 18	111.8 ± 30	1124.8 ± 236	5894.3 ± 743

Source: Fenton et al. 2009

Pregnant C57BL/6/Bkl mice were fed diets containing 0.3 mg PFOA/kg/day from GD 1 through the end of pregnancy. At birth, the PFOA concentrations in the offspring were 0.7 ± 0.1 µg/g in the brain and 16.3 ± 4.1 µg/g in the liver (Onishchenko et al. 2011).

Macon et al. (2011) gavaged CD-1 mice with 0, 0.3, 1.0, or 3.0 mg PFOA/kg from GD 1 to GD 17 or with 0, 0.01, 0.1, and 1.0 mg PFOA/kg from GD 10 to GD 17. In the full gestation experiment (GD 1–17), offspring were sacrificed on PNDs 7, 14, 21, 28, 42, 63, and 84, and in the half gestation experiment (GDs 10–17), female offspring were sacrificed on PNDs 1, 4, 7, 14, and 21. Serum, liver, and brain from the offspring were analyzed for PFOA by HPLC/MS/MS.

At the lowest dose, PFOA concentration in the serum peaked at or before PND 7, but the two higher doses peaked around PND 14 (Table 2-16). Calculated blood burdens which take into account the increasing blood volumes and body weights for females showed an inverted U-shaped curve peaking at PND 14 for all doses. In the liver, PFOA concentration decreased over time with the highest concentration observed at PND 7. Lower concentrations of PFOA were detected in the brain of the offspring on PND 7 and 14.

Table 2-16. Female Offspring PFOA Levels (ng/ml) in Mice After GD 1-17 Exposure

Tissue	Day	Dose		
		0.3 mg/kg	1.0 mg/kg	3.0 mg/kg
Serum	PND 7	4980 ± 218	11026 ± 915	20700 ± 3900
	PND 14	4535 ± 920	16950 ± 3606	26525 ± 2446
	PND 21	1194 ± 394	377 ± 607	8343 ± 1078
	PND 28	630 ± 162	1247 ± 208	4883 ± 1378
	PND 42	377 ± 81	663 ± 185	2058 ± 348
	PND 63	55 ± 17	176 ± 85	–
	PND 84	16 ± 5	71 ± 8	125
Liver	PND 7	2078 ± 90	8134 ± 740	16700 ± 749
	PND 14	972 ± 124	4152 ± 483	10290 ± 1028
	PND 21	1188 ± 182	1939 ± 637	2339 ± 1241
	PND 28	678 ± 130	2007 ± 560	7124 ± 1081
	PND 42	342 ± 87	617 ± 145	1145 ± 274
	PND 63	118 ± 22	320 ± 113	417 ± 160
	PND 84	43 ± 12	55 ± 12	235 ± 79
Brain	PND 7	150 ± 26	479 ± 41	1594 ± 162
	PND 14	65 ± 12	241 ± 20	650 ± 44
	PND 21	<LOQ	31 ± 5	133 ± 23
	PND 28	<LOQ	<LOQ	62 ± 93
	PND 42	<LOQ	<LOQ	<LOQ
	PND 63	<LOQ	<LOQ	<LOQ
	PND 84	<LOQ	<LOQ	<LOQ

Source: Macon et al. 2011

Notes:

– = not measured

LOQ: serum full gestation = 10-20 ng/g; liver = 35 ng/g; brain = 35 ng/g; late gestation serum = 5 ng/mL

After an exposure to low doses of PFOA from GD 10 to GD 17, serum PFOA concentration in the female offspring declined from PND 1 through the end of the experiment (Table 2-17). Calculated blood burden showed a gradual increase from PND 1 to PND 14, followed by a decline through PND 21.

Table 2-17. Female Offspring Serum PFOA Levels (ng/ml) in Mice After GD 10-17 Exposure

Tissue	Day	Dose		
		0.01 mg/kg	0.1 mg/kg	1.0 mg/kg
Serum	PND 1	284.5 ± 21.0	2303.5 ± 114.4	16305.5 ± 873.5
	PND 4	184.1 ± 12.1	–	–
	PND 7	150.7 ± 20.9	1277.8 ± 122.6	11880.3 ± 1447.6
	PND 14	80.2 ± 13.9	645.4 ± 114.2	6083.7 ± 662.6
	PND 21	16.5 ± 2.1	131.7 ± 24.5	2025.1 ± 281.9
Blood Burden (calculated)	PND 1	15.2 ± 1.7	114.3 ± 5.4	926.0 ± 47.6
	PND 4	20.6 ± 0.1	–	–
	PND 7	27.3 ± 3.8	221.7 ± 24.9	1965.9 ± 256.7
	PND 14	27.0 ± 4.6	218.5 ± 39.8	2033.6 ± 293.5
	PND 21	7.9 ± 1.0	66.4 ± 12.8	984.7 ± 142.8

Source: Macon et al. 2011

Note: – = not measured, blood burden determined by (body weight x (58.5/1000) x serum x 0.55)

White et al. (2011) measured serum PFOA concentrations in three generation of CD-1 mice (Table 2-18). Pregnant mice (F0, n = 10–12 dams/group) were gavaged with 0, 1, and 5 mg PFOA/kg from GD 1–17. A separate group of pregnant mice (n = 7–10 dams/group) were gavaged with either 0 or 1 mg PFOA/kg from GD 1–17 and received drinking water containing 5 parts per billion (ppb) PFOA beginning on GD 7 and continuing until the end of the study for their offspring, except during breeding and early gestation, to simulate a chronic low-dose exposure. An increase in serum PFOA concentration was observed in the control + 5 ppb PFOA groups in the F1 and F2 generations and in the 1-mg/kg + 5-ppb PFOA group of the F2 generation. A decrease was observed for the remaining groups.

Table 2-18. Serum PFOA Levels (ng/ml) in Mice Over Three Generations

	Generation/ Day	Dose			
		0 mg/kg + 5 ppb	1 mg/kg	1 mg/kg + 5 ppb	5 mg/kg
Dams at weaning	F0/PND 22	74.8 ± 11.3	6658.0 ± 650.5	4772.0 ± 282.4	26980.0 ± 1288.2
	F1/~PND 91	86.9 ± 14.5	9.3 ± 2.6	173.3 ± 36.4	18.7 ± 5.2
Offspring	F1/PND 22	21.3 ± 2.1	2443.8 ± 256.4	2743.8 ± 129.7	10045 ± 1125.6
	F1/PND 42	48.9 ± 4.7	609.5 ± 72.2	558.0 ± 55.8	1581.0 ± 245.1
	F1/PND 63	66.2 ± 4.1	210.7 ± 21.9	187.0 ± 24.1	760.3 ± 188.3
	F2/PND 22	26.6 ± 2.4	4.6 ± 1.2	28.5 ± 3.7	7.8 ± 1.9
	F2/PND 42	57.4 ± 2.9	0.4 ± 0.0	72.8 ± 5.8	0.4 ± 0.0
	F2/PND 63	68.5 ± 9.4	1.1 ± 0.5	69.2 ± 4.3	1.2 ± 0.5

Source: White et al. 2011

Subcellular Distribution. Han et al. (2005) examined the subcellular distribution of PFOA in the liver and kidney of male and female rats. Male and female Sprague-Dawley Crl:CD (SD)IGS BR rats were gavaged with 25 mg/kg [¹⁴C] PFOA and sacrificed 2 hours after dosing. Blood was collected and the liver and kidneys were removed. Five subcellular fractions (nuclei

and cell debris, lysosome and mitochondria, microsome, light microsome and ribosome, and membrane-free cytosol) were obtained by differential centrifugation. The radioactivity per gram (g) of each fraction and the total radioactivity were measured.

In the male liver, the highest proportion of total reactive residues (TRR) of PFOA was located in the nuclei and cell debris (40%). The TRR for the other subcellular fractions were as follows: membrane-free cytosol 26 percent% TRR, lysosome and mitochondria ~14% TRR, and microsome ~16% TRR. The level of PFOA in the light microsome and ribosome was ~1% TRR. In the female liver, the highest proportion of PFOA was found in the membrane-free cytosol, 48% TRR. The TRR were nuclei and cell debris ~31% TRR, lysosome and mitochondria ~12% TRR, and microsome ~8% TRR. As observed in the males, the level of PFOA in the light microsome and ribosome was ~1% TRR (Han et al. 2005).

In the male kidney, the level of PFOA was 79% TRR in the membrane-free cytosol, 15% TRR in the nuclei and cell debris, and 4% TRR in the lysosome and mitochondria/microsome/ light microsome and ribosome (combined). In the female kidney, the level of PFOA was 71% TRR in the cytosol, 21% TRR in the nuclei and cell debris, and 8% TRR in the lysosome and mitochondria/ microsome/light microsome and ribosome (combined). Further examination showed that in both genders, 98% of PFOA in the plasma was protein bound. The protein-bound fraction of PFOA in the liver cytosol was 56% TRR. In the kidney, the protein-bound fraction of PFOA in males was 42% TRR and 17% TRR in females (Han et al. 2005).

Based on the results, the authors concluded that subcellular distribution of PFOA in the rat liver was gender-dependent because the proportion of PFOA in the liver cytosol of female rats was almost twice that of the male rats. They hypothesized that the female might have a greater amount than the male of an unknown liver cytosolic binding protein with an affinity for perfluorinated acids. They also hypothesized that the unknown protein or protein complex might normally aid in transport of fatty acids from the liver. In the kidney, the subcellular distribution did not show the gender difference seen with the liver; however, the protein-bound fraction for the males (42%) was about twice that for the females (17%) (Han et al. 2005).

Inhalation Exposure

In a repeated exposure study, Hinderliter (2003) and Hinderliter et al. (2006b) exposed 6–8-week-old male and female rats (5 per gender per group) to 0-, 1-, 10-, and 25-mg/m³ aerosol concentrations of PFOA for 6 hours/day, 5 days/week for 3 weeks. Blood was collected immediately before and after the daily exposure period 3 days/week. The aerosols had MMADs of 1.3–1.9 µm with GSDs of 1.5–2.1. PFOA plasma concentrations were proportional to the inhalation exposure concentrations, and repeated exposures produced little plasma carryover in females, but significant day-to-day carryover in males. Male rats reached steady-state plasma levels of 8, 21, and 36 µg/ml for the 1-, 10-, and 25-mg/m³ groups, respectively, by 3 weeks. In females, the post-exposure plasma levels were 1, 2, and 4 µg/ml for the 1-, 10-, and 25-mg/m³ groups, respectively. When measured immediately before the next daily exposure, plasma levels had returned to baseline in females, demonstrating CL within 24 hours of each daily dose.

Dermal Exposure

No data were identified on tissue distribution following dermal exposures.

2.3 Metabolism

Several studies have examined metabolism of PFOA. However, no studies show clear evidence of metabolism. Ophaug and Singer (1980) found no change in fluoride ion level in the serum or urine following oral administration of PFOA to female Holtzman rats. Ylinen et al. (1989) found no evidence of phase II metabolism of PFOA following a single intraperitoneal PFOA dose (50 mg/kg) in male and female Wistar rats. The free anionic and possible conjugated forms of PFOA in the urine were separated using BondElut tubes. The tubes contain NH_2 , which is a weaker anion exchange sorbent and a good choice for retaining strong anions. The samples were aspirated through the tube, washed with water, and eluted with sodium bicarbonate/carbonate-buffer. The aspirate and eluate from the separation method were analyzed by gas chromatography. PFOA was not detected in the aspirate, but was retained with the cationic amino phase found in the eluate. This also occurred in control blanks spiked with PFOA. The authors concluded that because the PFOA anion was completely bound to the weak cationic amino phase in both the spiked controls and urine samples, PFOA in urine is not altered by phase II metabolism (Ylinen et al. 1989).

2.4 Excretion

Excretion data are available for oral exposure in humans and laboratory animals. Several studies have investigated the elimination of PFOA in humans, cynomolgus monkeys, and rats. In human females, elimination pathways include pregnancy (cord blood) and lactation (breast milk) (Apelberg et al. 2007; Tao et al. 2008; Thomsen et al. 2010; Völkel et al. 2008; von Ehrenstein et al. 2009).

Elimination half-lives differ among species. There are also significant gender differences in humans and some laboratory animal species. Information from humans does not, at this time, provide sufficient data to determine the magnitude of interindividual and gender differences in excretory half-lives. The transporters appear to play an important role in renal excretion of PFOA and possibly its biliary elimination as well.

Humans. The urinary excretion of PFOA in humans is impacted by the isomeric composition of the mixture present in blood and the gender/age of the individuals. The half-lives of the branched-chain PFOA isomers are shorter than those for the linear molecule, an indication that renal resorption is less likely with the branched chains.

Y. Zhang et al. (2013) determined half-lives for PFOA isomers based on paired serum samples and early morning urine samples collected from healthy volunteers in two large Chinese cities. Half-lives were determined using a one compartment model and an assumption of first order CL. The V_d applied in the analysis as determined by Thompson et al. (2010) was 170 mL/kg. CL was estimated from the concentration in urine normalized for creatinine and assuming excretion of 1.2 and 1.4 L/day of urine and 0.9 and 1.1 mg creatinine/day for males and females, respectively. The mean half-life for the sum of all PFOA isomers in younger females ($n = 12$) was 2.1 years (range 0.19–5.2 years) while that for all males and older females ($n = 31$) was 2.6 (range 0.0059–14 years); the medians were 1.8 and 1.7 years, respectively. The mean values for the four branched-chain isomers of PFOA were lower than the value for the linear chain, suggesting that resorption transporters might favor uptake of the linear chain over the branched-chain isomers. Older females and males have longer half-lives than young females, suggesting the importance of monthly menstruation as a pathway for excretion (Y. Zhang et al. 2013).

T. Zhang et al. (2014) derived estimates for PFOA's urinary excretion rate using paired urine and blood samples from 54 adults (29 males and 25 females) in the general population and 27 pregnant females in Tainjin, China. The age range for the general population was 22–62 years and for the pregnant females was 21–39 years. Urinary excretion was calculated based on the concentration in the urine times volume of urine wherein a urinary volume of 1,200 mL/day was applied to all females and 1,600 mL/day for all males. Urine samples were first-draw morning samples. Total daily intakes for PFOA were calculated from the concentration in blood using first order assumptions, a half-life of 2.3 years (Bartell et al. 2010) and a V_d of 170 mL/kg (Lorber and Egeghy 2011; Thompson et al. 2010). PFOA was detected in the blood samples for all participants but for only 76% of the urine samples from the general population and 30% for the pregnant females. There was a direct correlation between the PFOA concentrations in blood and creatinine adjusted urine ($r = 0.348$ $p = 0.013$) for the general population but not for the pregnant females. When limited to the eight females who had detectable levels in both blood and urine, there was a significant correlation ($r = 0.724$, $p = 0.042$).

Among the general population, the daily urinary excretion rate accounted for 25% of the estimated intake with the excretion higher in males (31%) than in females (19%). The urine: blood ratio was lower for pregnant females than for nonpregnant females (0.0011 versus 0.0029), suggesting other removal pathways such as placenta and cord blood. There was little difference between the younger menstruating females (21–50 years versus 51–61 years), but there is no indication that data were collected from the participants relative to menstruation status on the day of blood and urine collection.

Wong et al. (2014) looked at the role of menstrual blood as an excretory pathway to explain the shorter half-life of PFOS in females than in males. They fit a population-based PK model to six cross-sectional NHANES data sets (1999–2012) for males and females. They concluded that menstruation could account for about 30% of the PFOS elimination half-life difference between females and males. Although Wong et al. (2014) studied PFOS and not PFOA, their findings are relevant to both chemicals.

Elimination of PFOA by way of the gastrointestinal tract was reported in a case history of a single human male with high serum levels of perfluorinated chemicals that appeared to originate from household dust following the installation of new carpeting (Genuis et al. 2010). Treatment with cholestyramine, a bile acid sequestrant for 20 weeks (4g/day, three times a day), lowered his serum PFOA concentration from 5.9 ng/g serum to 4.1 ng/g serum. More dramatic decreases were observed with serum PFOS (23–14.4 ng/g serum) and PFHxS (58–46.8 ng/g serum), which were present at higher levels in the serum. This observation suggests that excretion with bile and possible enterohepatic resorption via intestinal transporters limits the loss of absorbed PFOA via feces in the absence of a binding agent such as cholestyramine.

2.5 Animal Studies

Oral Exposure

Monkey. Butenhoff et al. (2004b) studied the fate of PFOA in cynomolgus monkeys in a 6-month oral exposure study. Groups of four to six male monkeys each were administered PFOA daily via oral capsule at DRs of 0, 3, 10, and 30/20 mg/kg for 6 months. Two monkeys exposed to 10 mg/kg and three monkeys exposed to 20 mg/kg were monitored for 21 weeks (recovery period) following dosing. Urine and fecal samples were collected at 2-week intervals and were analyzed for PFOA concentrations.

Urine PFOA concentrations over the duration of the study were 53 ± 25 , 166 ± 83 , and 181 ± 100 $\mu\text{g/ml}$ in the 3-, 10-, and 30-/20-mg/kg dose groups, respectively, and reached steady-state after 4 weeks. Within two weeks of recovery, urine PFOA concentrations were $<1\%$ of the value measured during treatment and decreased slowly thereafter. Fecal PFOA concentrations were 6.8 ± 5.3 , 28 ± 20 , and 50 ± 33 $\mu\text{g/g}$ in the 3-, 10-, and 20-mg/kg dose groups, respectively. Within two weeks of recovery, fecal PFOA concentrations dropped to less than 10% of the last value during treatment, and then declined slowly. These results are consistent with both renal and biliary excretion in male monkeys.

Rat. There have been a number of studies of excretion in rats because of the gender differences noted in serum levels. Hinderliter (2004) and Hinderliter et al. (2006a) investigated the relationship between age and urine PFOA concentrations in male and female Sprague-Dawley rats. Immature rats 3, 4, or 5 weeks of age were administered PFOA via oral gavage as a single dose of 10 or 30 mg/kg. Two hours after dosing, five rats per gender per age group and dose group were sacrificed and blood samples were collected (see section 2.2.1). The remaining five rats per gender per age and dose group were placed in metabolism cages for 24-hour urine collection. Urinary output (volume) was not quantified or standardized for creatinine levels.

Urine PFOA concentrations differed significantly with age, dose, and gender ($p < 0.01$, Table 2-19). Urinary excretion of PFOA was substantially higher in females than in males, and the female urine PFOA concentrations increased with age. In male rats, 24-hour urine PFOA concentrations decreased with age up to five weeks. In both genders, urine PFOA was higher (2.5 to 6.5 times) at the 30-mg/kg dose as compared to the 10-mg/kg dose.

There was a difference in urinary excretion between the 3-week-old and 4/5-week-old male rats, with the older rats excreting $\sim 50\%$ less PFOA in the urine than the younger rats at 10 mg/kg and 30 mg/kg. If the data from urine are integrated with the plasma data in the same study (Table 2-9), the male plasma levels increased from the 3-week value and were relatively stable for weeks 4 and 5. In the females, urine excretion increased gradually with age (Table 2-19) and plasma concentrations decreased (Table 2-10).

Table 2-19. Urine PFOA Concentrations in Male and Female Rats

Age (weeks)	Dose (mg/kg)	Urine PFOA ($\mu\text{g/ml}$ at 24 hours post-dose)			
		Male		Female	
		Mean	SD	Mean	SD
3	10	9.57	4.86	21.17	8.95
4	10	4.53	2.45	23.26	15.27
5	10	4.03	2.36	49.77	24.64
3	30	51.76	28.86	94.89	26.26
4	30	28.70	18.84	104.12	28.97
5	30	15.65	6.24	123.16	51.56

Source: Hinderliter 2004

Hundley et al. (2006) examined excretion of PFOA in one male and one female CD rat (sexually mature). Each was given a single dose of 10 mg/kg ^{14}C -PFOA and housed in a metabolism cage. Urine and feces were collected at 12, 24, 48, 72, 96, and 120 hours post-dose. The female rat excreted more PFOA over the 120-hour collection period than the male rat. In the male rat, 25.6% and 9.2% ^{14}C -PFOA were excreted in the urine and feces, respectively. In the female rat, 73.9% and 27.8% ^{14}C -PFOA were excreted in the urine and feces, respectively. The

female rat excreted almost all of the PFOA by 48 hours compared with only 19% of the dose excreted by the male rat over the same amount of time. The cumulative percent of the dose excreted is shown in Table 2-20.

Table 2-20. Cumulative Percent ¹⁴C-PFOA Excreted in Urine and Feces by Rats

Rat	Hours After Dosing					
	12	24	48	72	96	120
Male	0.6	8.7	19.2	23.4	30.2	34.3
Female	52.5	96.4	99.8	100.0	100.0	100.0

Source: Hundley et al. 2006

Adult male Sprague-Dawley rats (n = 7) were given a single gavage dose of 0.5 mg PFOA/kg and monitored for 38 days (Benskin et al 2009). Over the course of the study, the rats were held in metabolic cages and urine and feces were collected. The mean blood PFOA concentration was 1.1 µg/mL 24 hours post-dose. During the first 24 hours post-dose, 65% of PFOA was excreted in the urine; most of the PFOA that was not absorbed was excreted in the feces. After that time period, 91–95% of the daily excreted PFOA was eliminated in the urine. On day 3, the mean PFOA concentration in urine and feces were 265 ng/g and 28 ng/g. The half-life for elimination from plasma in male rats was 13.4 days.

Cui et al. (2010) exposed 2-month-old male Sprague-Dawley rats (10 per group) to PFOA (96% active ingredient) at 0, 5, and 20 mg/kg/day once daily by gavage for 28 days. Urine and fecal samples were collected through use of metabolism cages at 24-hour intervals immediately following dosing on days 1, 2, 5, 7, 10, 14, 18, 21, 24, and 28 of the study. Daily urine volume and fecal weight were comparable across all groups throughout the study. As measured by excretion 24-hours after the first dose, 17.9% of the applied dose was excreted in the urine of the low-dose group and 22% for the high-dose group. The percent of the absorbed dose was 92.8% and 92.3% for the low and high doses, respectively, when the fecal excretion over the 24 hours following dosing was estimated to be unabsorbed material. During week 1, a sharp increase in urinary and fecal excretion expressed as percent of dose/day was observed in rats of both groups. The excretion rate leveled off at about 50% for the low-dose animals for the remainder of the 28 days. In the case of the high-dose animals, the urinary excretion remained level at about 80% for the second and third weeks and then increased sharply to about 140% at 28 days. The fecal excretion rates were 7.2% and 7.7% for rats in the 5- and 20-mg/kg groups, respectively, during the first 24 hours post-dosing and continued an upward trend throughout the 28 days with the terminal percent/day about 25% for the low-dose group and 40% for the high-dose group.

Dose is an important variable that impacts excretion. Rigden et al. (2015) exposed groups of five male Sprague-Dawley rats to doses of 0, 10, 33, and 100 mg/kg/day for 3 days and maintained them for 3 additional days; overnight urine was collected and body weight was measured daily. Of greatest interest relative to the limitations on renal resorption, is the dose-related increase in urine PFOA concentration and urine PFOA concentration per mg creatinine for the 33- and 100-mg/kg/day groups compared to the 10-mg/kg/day group. The peak in PFOA excretion normalized to creatinine occurred on day 3 after the cessation of dosing. The concentration at 33 mg/kg/day was 500 times greater than that at 10 mg/kg/day. At the 100-mg/kg/day dose, the peak concentration was about 3,200 times greater than for the low dose. The low-dose excretion was only slightly greater than the controls. The urine results support the renal resorption hypothesis concept and suggest that there is a threshold limit on resorption that,

once exceeded, dramatically increases PFOA loss in urine. As a consequence, half-life for continuous low-dose exposures will be longer than for single or short-term high-dose exposures.

Other Species. Hundley et al. (2006) examined excretion of PFOA in CD mice, BIO-15.16 hamsters, and New Zealand White rabbits. One male and one female of each species was given a single dose of 10-mg/kg ¹⁴C-PFOA and housed in metabolism cages. Urine and feces were collected at 12, 24, 48, 72, 96, and 120 hours post-dose. Additional samples were collected from rabbits at 144 and 168 hours post-dose.

Over 120 hours, the male mouse excreted 3.4% ¹⁴C-PFOA in urine and 8.3% ¹⁴C-PFOA in feces, and the female mouse excreted 6.7% ¹⁴C-PFOA in urine and 5.7% ¹⁴C-PFOA in feces. The mice were similar in the amounts excreted. The male hamster excreted 90.3% and 8.2% ¹⁴C-PFOA in urine and feces, respectively, and the female hamster excreted 45.3% and 9.3% ¹⁴C-PFOA. The male hamster excreted a greater amount of ¹⁴C-PFOA than the female hamster. Over 84% of ¹⁴C-PFOA was excreted 24 hours after dosing by the male hamster compared to less than 25% of ¹⁴C-PFOA excreted by the female hamster at 24 hours after dosing. Over 168 hours, the male rabbit excreted 76.8% and 4.2% ¹⁴C-PFOA in urine and feces, respectively, and the female rabbit excreted 87.9% and 4.6% ¹⁴C-PFOA. Both rabbits excreted most of the dose by 24 hours. The cumulative percentage of ¹⁴C-PFOA excreted is shown in Table 2-21.

Table 2-21. Cumulative Percent ¹⁴C-PFOA Excreted in Urine and Feces

Species	Gender	Hours After Dosing						
		12	24	48	72	96	120	168
Mouse	Male	0.4	4.1	6.7	8.6	9.1	10.8	-
	Female	0.2	4.1	6.5	8.4	9.0	11.0	-
Hamster	Male	67.3	84.5	96.1	97.4	98.2	98.4	-
	Female	11.3	24.6	36.4	43.9	50.1	54.0	-
Rabbit	Male	77.8	80.2	80.4	80.4	80.4	80.4	80.4
	Female	86.7	90.5	92.0	92.2	92.7	92.9	93.0

Source: Hundley et al. 2006

When the data in Table 2-21 are integrated with the data from rats, the gender differences in PFOA excretion rate appear to be species-specific. Female rats, male hamsters, and both genders of rabbits appear to be good excreters based on their response to a radiolabeled dose of 10 mg/kg. Most of the dosed material is excreted within 24 hours after dosing. Female hamsters apparently are moderate excreters. Males and female mice excreted only about 10% of the dose over the 120 hours (5 days) after dosing. Mice do not show a gender difference but retain more of the dose than do hamsters, rabbits, and female rats. The long half-lives in humans suggest that their excretion rates are more like mice or male rats.

Inhalation Exposure

Although no data were identified on urine or fecal excretion of PFOA following inhalation exposures, the Hinderliter study (2003) provides evidence of CL following single and repeated inhalation exposures in Sprague-Dawley rats. Plasma PFOA concentrations following a single exposure to 1, 10, and 25 mg/m³ PFOA declined 1 hour after exposure in females and 6 hours after exposure in males. In females, the elimination of PFOA was rapid at all exposure levels and, by 12 hours after exposure, their plasma levels had dropped below the analytical LOQ (0.1 µg/ml). In males, the plasma elimination was much slower and, at 24 hours after exposure, the plasma concentrations were approximately 90% of the peak concentrations at all exposure

levels. In the repeated exposure study, male and female rats were exposed to the same concentrations for 6 hours/day, 5 days/week for 3 weeks. Steady-state plasma levels were reached in males by 3 weeks, but plasma PFOA levels in females returned to baseline with 24 hours of each dose. The data are illustrative of distinct toxicokinetic differences between male and female rats in their response to PFOA exposure (Hinderliter 2003).

Dermal Exposure

No data were identified on excretion following dermal exposures. Minimal fecal excretion is anticipated for the dermal route of exposure although the biliary pathway can be a route for excretion of material absorbed through the skin, distributed to the liver, and discharged to the gastrointestinal tract.

2.5.1 Mechanistic Studies of Renal Excretion

Several studies have been conducted to elucidate the cause of the gender difference in the elimination of PFOA by rats. Many of the studies have focused on the role of transporters in the kidney tubules. Most studies have examined the OATs located in the proximal portion of the descending tubule. OATs are found in other tissues as well and were discussed earlier for their role in absorption and distribution. In the kidney, they are responsible for delivery of organic anions, including a large number of medications from the serum into the kidney tubule for excretion as well as reabsorption of anions from the glomerular filtrate. The transporters are particularly important in excretion of PFOA because it binds to surfaces of serum proteins (particularly albumin), which makes much of it unavailable for removal during glomerular filtration. Other transporter families believed to be involved in renal excretion are the OATPs and the MRPs. However, they have not been evaluated as extensively as the OATs for their role in renal excretion.

OATs are located on both the basolateral (serum interface) and apical surfaces of the brush boarder of the proximal tubule inner surface. At the basolateral surface, the OATs transport the perfluorooctanoate anion from the serum to the tubular cells (Anzai et al. 2006; Cheng and Klaassen 2008; Klaassen and Aleksunes 2010; Klaassen and Lu 2008; Nakagawa et al. 2007, 2009). OAT1, 2, and 3 are located on the basolateral membrane surface. OAT4 and OAT5 are located on the apical surface of the tubular cells, where they reabsorb the PFOA anions from the glomerular filtrate. Figure 2-2 diagrams the flow of organic anions such as the PFOA anion from serum to the glomerular filtrate for excretion and resorption of organic acids from the glomerular filtrate with transport back to serum. OATs can function for uptake into the cell across both the basolateral and apical surfaces.

Several MRP transporters also appear to function in the kidney and move organic anions in and out of cells at both the basolateral surface (e.g., MRP2/4) and the apical surface (e.g., MRP1) as well as one or more OATPs on each surface (Cheng and Klaassen 2009; Klaassen and Aleksunes 2010; Klaassen and Lu 2008; Kusuhara and Sugiyama 2009; Launay-Vacher et al. 2006; Yang et al. 2009). Bidirectional movement of PFOA across both the basolateral and apical surfaces is driven by concentration gradients and/or active transport. Far more data exist on PFOA and OATs in the kidneys than on OATPs and MRPs. Abbreviations for individual transporters on the basolateral and apical surfaces differ across publications. The accepted convention is to use uppercase letters to refer to human transporters and lowercase letters to refer to animal transporters. For this report, the data are not reported by species but by transporter family and the uppercase letters are used.

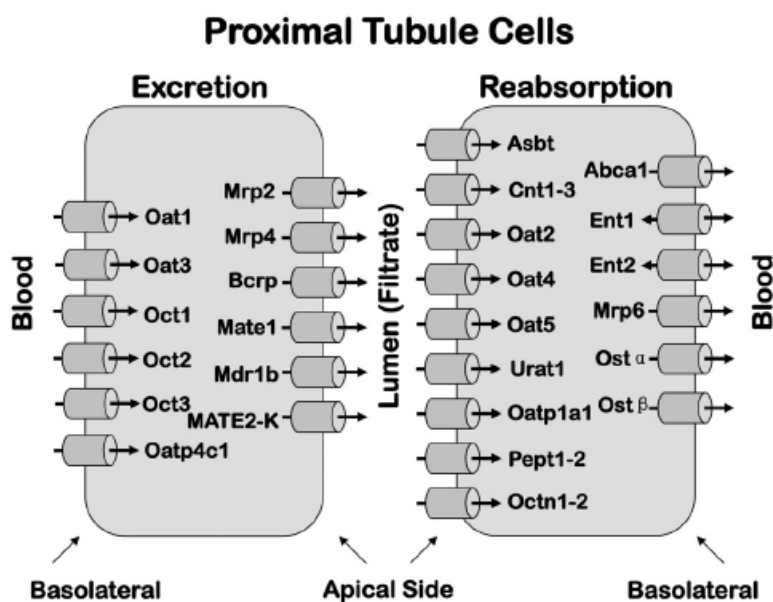

Source: Klaassen and Aleksunes 2010

Figure 2-2. Localization of Transport Proteins

Knowledge about specific OAT, OATP, and MRP transporters in the kidneys is rapidly evolving. A low membrane density or blockage of basolateral OATs will decrease PFOA excretion while low membrane densities or blockage of apical OATs will increase excretion because they decrease resorption of anions from the glomerular filtrate.

The earliest studies of the impact of gender on urinary excretion were conducted by Hanhijarvi et al. (1982) using probenecid, an inhibitor of renal excretion of organic acids on PFOA excretion in male and female Holtzman rats. The female rats that had not received the probenecid excreted 76% of the administered dose of PFOA over a 7-hour period, while males excreted only 7.8% of the administered dose over the same period of time. Probenecid administration modified the cumulative excretion curve for males only slightly. In females, however, probenecid markedly reduced PFOA elimination to 11.8%. The authors concluded that the female rat possesses an active secretory mechanism that rapidly eliminates PFOA from the body that male rats do not possess.

Kudo et al. (2002) examined the role of sex hormones and OATs on the renal clearance (CL_R) of PFOA. Renal mRNA levels of specific OATs in castrated male and ovariectomized (OVX) female Wistar rats also were determined. Castration of male rats caused a 14-fold increase in CL_R of PFOA. The elevated PFOA CL_R in castrated males was reduced by treating them with testosterone. Treatment of male rats with estradiol increased the CL_R of PFOA. In female rats, ovariectomy caused a significant increase in CL_R of PFOA (a twofold increase), but the administration of estradiol to OVX female rats returned CL_R of PFOA to normal values. Treatments of female rats with testosterone reduced the CL_R of PFOA.

Treatment with probenecid, a known inhibitor of OAT1–6 and OAT8, markedly reduced the CL_R of PFOA in male rats, castrated male rats, and female rats (Kudo et al. 2002). Accordingly, the male sex hormones appear to decrease the presence of OATs in the renal basolateral membranes while the female sex hormones appear to increase the transporters.

To identify the transporter molecules responsible for PFOA transport in the rat kidney, renal mRNA levels of specific OATs were determined in male and female rats under various hormonal states and compared with the CL_R of PFOA. The level of OAT2 mRNA in male rats was only 13% of the level in female rats. Castration or estradiol treatment increased the level of OAT2 mRNA whereas treatment of castrated male rats with testosterone reduced it. Ovariectomy of female rats significantly increased the level of OAT3 mRNA. Multiple regression analysis of the data suggested that OAT2 and OAT3 are responsible for urinary elimination of PFOA in the rat; however, the possibility of a resorption process mediated by OATP1 was mentioned as a possible factor in male rat retention of PFOA. OAT2 and OAT3 are located on the basolateral cell surface. OATP1 is located on the apical surface of the renal tubule cells (Kudo et al. 2002).

Cheng et al. (2006) examined whether sex hormones influenced gender-specific OATP expression in the kidneys of adult male and female C57BL/6 mice. Gonadectomized mice were used for the studies in conjunction with hormone replacement measures (5 α -dihydroxy-testosterone [DHT] or 17- β estradiol [E2]). OATP1a1 and OATP3a1 were evaluated. Treatment with DHT resulted in significant increase in both OATPs in the kidneys of male and female gonadectomized mice. In both cases, the change in males was greater than the change in females. Treatment with E2 almost abolished the expression of OATP1a1 in the kidneys but caused no significant change in OATP3a1. In the intact control animals, almost no expression of OATP1a1 occurred in the kidneys of females and a significantly lower expression of OATP3a1 ($p < 0.05$) occurred. In the gonadectomized control animals, little or no expression of OATP1a1 occurred in either gender, and expression of OATP3a1 was equivalent in both genders.

Nakagawa et al. (2007) investigated the role of OATs in the renal excretion of PFOA using *in vitro* methods. HEK293-transformed cells, derived from human embryonic kidney (HEK), were transfected with human or rat OAT1, OAT2, or OAT3 constructs. Cells from the S2 segment of the proximal tubule were transfected with human or rat OAT2 constructs. HEK293 and S2 cells transfected with the vector served only as control cells. The transfected HEK293 cells were incubated for 1 min with or without 0, 10, and 100 μmol [^{14}C]PFOA and/or varying concentrations of favored OAT substrates to determine inhibitory effects of PFOA as follows: 5 μmol [^{14}C]para-aminohippuric acid (OAT1), 20 nmol [^{14}C]estrone sulfate (OAT3), and 10 nmol [^{14}C]prostaglandin $F_{2\alpha}$ (OAT2).

PFOA significantly inhibited para-aminohippuric acid and estrone sulfate uptake mediated by OAT1 and OAT3, respectively. At 10 μmol PFOA, uptake of 5 μmol [^{14}C] para-aminohippuric acid was 75–85% of the control level and, at 100 μmol PFOA, uptake was reduced to 35–45% of control. Estrone sulfate uptake by human OAT3 was 65% of the control level at 10 μmol PFOA and 40% of control at 100 μmol PFOA. Estrone sulfate uptake by rat OAT3 was 15% of the control level in the presence of 10 μmol PFOA and was almost completely inhibited at 100 μmol PFOA. Prostaglandin $F_{2\alpha}$ uptake by OAT2 was inhibited moderately by PFOA, 75–85% of control at 10 μmol PFOA, and 65% of control at 100 μmol PFOA.

In the second part of their study, Nakagawa et al. (2007) incubated HEK293 and S2 transfected cells with 10 μmol [^{14}C]PFOA for 1 min to determine uptake. Time-dependent uptake of 5 μmol [^{14}C]PFOA from 0 to 30 mins was conducted in the HEK293 cells transfected with human or rat OAT1, OAT2, or OAT3. Experiments were conducted in triplicate. Uptake of PFOA was stimulated ($p < 0.001$) in cells transfected with human or rat OAT1 or OAT3, while no uptake was stimulated in cells transfected with OAT2 in either cell line. In the time-dependent experiments, uptake by human or rat OAT1 or OAT3 increased linearly up to 2 mins and reached a plateau in about 15 mins. Kinetic evaluations resulted in substrate concentration at which the

initial reaction rate is half maximal (K_m) values of 48.0, 51.0, 49.1, and 80.2 μmol for human OAT1, rat OAT1, human OAT3, and rat OAT3, respectively. The authors showed that both human and rat OAT1 and OAT3 transport PFOA in the kidney while human and rat OAT2 do not (Nakagawa et al. 2007).

Yang et al. (2009) investigated the role of OAT polypeptide 1a1 (OATP1a1) in the renal elimination of PFOA. The polypeptide is located on the apical side of proximal tubule cells and could be the mechanism for renal reabsorption of PFOA in rats. The level of mRNA of OATP1a1 in male rat kidney is 5–20-fold higher than in female rat kidney, OATP1a1 protein expression is higher in male rat kidneys, and it is regulated by sex hormones. One of its known substrates is estrone-3-sulfate (E3S). A substantial presence of OATP1a1 in male rats would favor resorption of PFOA in the glomerular filtrate and reduce excretion.

Chinese hamster ovary (CHO) cells were transfected with rat OATP1a1 complementary DNA. The transfected CHO cells were incubated with 4 μmol [^{14}C]PFOA for up to 10 mins or with 0–1,000 μmol [^{14}C]PFOA for 2 mins to determine uptake. The difference between the uptake velocities of CHO OATP1a1-transfected cells and CHO vector-transfected cells was defined as active PFOA uptake by the tubular epithelium. The transfected CHO cells were incubated with 5 μmol [^{14}C]PFOA for 2 mins in the absence or presence of inhibitors (e.g., BSP, taurocholate, probenecid, *p*-aminohippurate, and naringin [a flavonoid found in grapefruit]) for inhibition studies. The transfected CHO cells were incubated with 2 μmol E3S and 0, 0.1, or 1 mM perfluorocarboxylates with carbon chain lengths ranging from 4 to 12, including PFOA (C8) for 30 seconds for E3S inhibition studies.

In time-dependent uptake experiments, uptake of PFOA by OATP1a1-transfected cells increased proportionally to time during the first 2 mins of incubation. Vector-transfected cells had a significant level of uptake of PFOA attributed to nonspecific passive diffusion. In the concentration-dependent uptake experiments, uptake velocity of PFOA in OATP1a1-transfected cells increased with increasing concentration and saturation levels were not reached. In vector-transfected cells, uptake velocities increased linearly with increasing concentration of PFOA, demonstrating a passive diffusion mechanism. Active PFOA uptake—the difference between the uptake of the OATP1a1 cells and the vector-transfected cells—could be described by the Michaelis-Menton equation and exhibited saturable kinetics.

Inhibition experiments with substrates of OATs and OATPs showed that BSP, taurocholate, and naringin inhibited PFOA uptake to 10–30% of control and *p*-aminohippurate inhibited PFOA uptake to 62% of control. Probenecid, an OAT inhibitor, did not inhibit PFOA uptake at all. In OATP1a1-transfected cells, uptake of E3S was inhibited to less than 10% of control uptake following incubation with 1 mM [^{14}C]PFOA. Inhibition of E3S was less than 50% of control uptake after incubation with 0.1 mM [^{14}C]PFOA. Based on the results of the uptake and inhibition experiments, the authors suggested that passive diffusion could be an important route of PFOA distribution and that renal reabsorption in the male rat could be mediated by OATP1a1.

Nakagawa et al. (2009) investigated the role that the human organic acid transporter (OAT4) plays in transporting PFOA. Human OAT4 is located on the apical side of proximal tubule cells and mediates reabsorption of organic anions. Transformed cells derived from HEK cells, HEK293, were transfected with human OAT1, OAT3, or OAT4 constructs. HEK293 cells transfected with only the vector served as control cells. The transfected HEK293 cells were incubated with 10 μmol [^{14}C]PFOA for 15 mins to determine uptake. Transfected cells also were incubated with 10 μmol [^{14}C]PFOA for 15 mins and then washed with incubation medium

containing 1%, 3%, and 5% BSA to investigate the contribution of nonspecific binding of PFOA on the cell membrane. Experiments were conducted in triplicate.

Uptake of PFOA was significantly stimulated ($p < 0.01$) in cells transfected with human OAT1, OAT3, and OAT4. Uptake of PFOA in human OAT1 transfected cells was 1.6-fold higher than in control cells. In human OAT3 transfected cells, PFOA uptake was ~2.4-fold higher than in control cells. In human OAT4 transfected cells, PFOA uptake was 2.7-fold higher than in control cells. Accumulation of PFOA in transfected human OAT4 cells also was significantly greater than in human OAT1 cells ($p < 0.01$). Washing the cells with BSA reduced PFOA uptake by 30% at most, suggesting mediation by the transporters into the transfected cells. The experiments showed that human OAT4 transports PFOA and that human OAT4 activity might play a role in reabsorption of PFOA from the tubule, resulting in poor urinary excretion.

Yang et al. (2010) examined cellular uptake of PFOA by OATP1A2, OAT4, and urate transporter 1 (URAT1) to determine their roles in mediating human renal reabsorption. CHO and HEK293 cells were transfected with OATP1A2, OAT4, and URAT1 plasmid DNA or vector DNA (control). In uptake studies, PFOA incubation times were 10 seconds (OAT4) and 30 seconds (URAT1). Cells transfected with OAT4 were incubated with 5 μmol PFOA for up to 1 min in time-dependent uptake experiments. In inhibition studies, cells transfected with OAT4 were incubated with 5 μmol [^{14}C]PFOA for 10 seconds in the presence and absence of 100 μmol sulfobromophthalein (BSP), probenecid, glutarate, or polycyclic aromatic hydrocarbon (PAH). Perfluorinated carboxylates with differing chain lengths (C4–C12) were used in chain length-dependent inhibition experiments. Incubations with ^3H -E3S (OAT4 and OATP1A2) or 6 μmol C^{14} -uric acid (URAT1) in the presence and absence of 100 μmol perfluorinated carboxylate lasted 10 seconds (OAT4), 30 seconds (OATP1A2), and 1 min (URAT1).

PFOA uptake in OATP1A2-transfected HEK293 cells was no different than uptake in control cells. At 100 μmol , E3S uptake was inhibited ~30% by PFOA (C8), ~62% by C9, ~70% by C10, ~42% by C11, and ~18% by C12. E3S uptake was not inhibited by C4–C7. In CHO cells transfected with OAT4, time-dependent uptake experiments showed a saturation phase after an incubation time of approximately 10 seconds. A pH-dependent increase in PFOA uptake was observed with approximately 90% uptake at pH 8 and 250% at pH 5.5.

In concentration-dependent uptake experiments, uptake increased with increasing PFOA concentration (0–1000 μmol) in OAT4-transfected CHO cells at pH 7.4 and 6. PFOA uptake was cis-inhibited by BSP and probenecid and trans-stimulated by PAH and glutarate at pH 7.4. A chain length-dependent effect was observed in E3S inhibition on OAT4-expressing cells in the presence of C7 (30%) through C10 (~80%). Inhibition in the presence of C11 and C12 were ~52% and ~30%, respectively. Inhibition of E3S in the presence of C4, C5, and C6 was less than 20% for each.

PFOA uptake in HEK293 cells transfected with URAT1 was not statistically different from control cells in the presence and absence of Cl^- . Under both conditions, PFOA intake was enhanced especially in the absence of Cl^- in which PFOA uptake was greater than fourfold compared to uptake in control cells. Time-dependent PFOA (5 μmol) uptake by URAT1 increased with time during the 5-min incubation period, and a concentration-dependent increase in PFOA uptake was observed (0–700 μmol). Urate uptake was inhibited in a chain length-dependent manner. Inhibition in the presence of C7–C10 was ~70% each, ~60% in the presence of C6 and C11, ~50% in the presence of C5, ~30% in the presence of C12, and ~25% in the presence of C4. Based on the results, Yang et al. (2010) concluded that PFOA was not a

substrate for OATP1A2, but that OAT4 and URAT1 were probably involved in the renal reabsorption of PFOA.

Weaver et al. (2010) published *in vitro* studies on the transport activities of the rat renal transporters OAT1, OAT2, OAT3, OATP1a1, and URAT1. The transporters were transfected into one of several cell lines and exposed to a series of perfluorinated carboxylates having chain lengths ranging from 2 to 18 carbons (C). The activity of the perfluorinated carboxylate on the transporters was quantified on the basis of its ability to inhibit the transport of a favored radiolabeled substrate. The PFAS inhibition of the individual transporters varied with chain length. The perfluorinated carboxylate with 6, 7, and 8 carbon chains caused a significant decrease in OAT1 transport of tritiated p-aminohippurate, with the C7 acid having the strongest effect. The perfluorinated carboxylates with 5 through 10 carbon chains caused a significant decrease in transport of tritiated E3S by OAT3, with C8 and C9 acids having the strongest effect. The transport of tritiated estadiol-17 β -glucuronide by OATP1a1 was significantly inhibited by perfluorinated carboxylates with 6 through 11 carbon chains, with C10 acid having the strongest effect. The perfluorinated carboxylate did not inhibit OAT2 or URAT1 transport of favored substrates.

The kinetic response of the OAT1, OAT3, and OATP1a1 transporters to increasing concentrations of selected perfluorinated carboxylates also was evaluated by Weaver et al. (2010). The change in transport velocity (ng/mg protein/min) with increasing concentrations of the perfluorinated carboxylate exhibited a Michaelis-Menton-type response. The kinetic data were analyzed to determine the K_m and V_{max} , and the results are summarized in Table 2-22 below.

Table 2-22. Kinetic Parameters of Perfluorinated Carboxylate Transport by OAT1, OAT3, and OATP1a1

Transporter	PFAS	K_m (μ mol)	V_{max} (nmol/mg protein/min)
OAT1	C7	50.5 \pm 13.9	2.2 \pm 0.2
	C8	43.2 \pm 15.5	2.6 \pm 0.3
OAT3	C8	65.7 \pm 12.1	3.8 \pm 0.5
	C9	174.5 \pm 32.4	8.7 \pm 0.7
OATP1a1	C8	126.4 \pm 23.9	9.3 \pm 1.4
	C9	20.5 \pm 6.8	3.6 \pm 0.5
	C10	28.5 \pm 5.6	3.8 \pm 0.3

Source: Weaver et al. 2010

The Michaelis-Menton kinetic data (K_m and V_{max} [maximum initial rate of an enzyme catalyzed reaction]) indicate that there are substantial differences in the affinity of the perfluorinated carboxylate with 8 and 9 carbon chains for OAT3, with the C8 acid favored over the C9 acid. OAT3 is an export transporter located on the basolateral side of the tubular cells; thus, when present in a mixture consisting of comparable concentrations of both, renal tubular excretion of the C8 acid would tend to decrease excretion of the C9 acid. For OATP1a1, a resorption transporter located on the apical side of the renal tubular cells, the C9 and C10 acid have a greater affinity for the transport protein than the C8 acid. The kinetic data suggest that the net impact of these relationships would be to favor excretion of the C8 acid over the C9 acid and possibly the C10 acid when all three fluorocarbons are present in the exposure matrix at approximately equal concentrations. There were minimal kinetic differences between transport

of the C7 and C8 acids by OAT1, an export transporter on the basolateral surface of the renal tubular cells.

Based on the Hinderliter study (2004), a developmental change in renal transport occurs in female rats between 3 and 5 weeks of age that allows for expedited excretion of PFOA. When the transporters become active, there is a decrease in plasma PFOA levels and an increase in urinary excretion (Table 2-23). The developmental change in male rats appears to have the opposite effect. Sexual maturity appears to influence these events because castrated male rats become more like females and OVX females become more like males in their PFOA excretion capabilities. The change in female rats seems to involve the OATs (Kudo et al. 2002) while the change in males seems to involve the OATPs (Cheng et al. 2006).

Table 2-23. Plasma and Urine PFOA Concentration 24-hr After Treatment with 30 mg/kg PFOA

Age (weeks)	Female		Male	
	Plasma (µg/ml)	Urine (µg/ml)	Plasma (µg/ml)	Urine (µg/ml)
3	51.43 ± 13.61	94.89 ± 26.26	74.16 ± 18.23	51.76 ± 28.86
4	28.01 ± 9.90	104.12 ± 28.97	100.81 ± 13.18	28.70 ± 18.84
5	3.42 ± 1.95	123.16 ± 51.56	113.86 ± 23.36	15.65 ± 6.24

Source: Hinderliter 2004

When considered together, the studies of the transporters suggest that female rats are efficient in transporting PFOA across the basolateral and apical membranes of the proximal kidney tubules into the glomerular filtrate, but male rats are not. Males, on the other hand, have a higher rate of resorption than females for the smaller amount they can transport into the glomerular filtrate via OATP1a1 in the apical membrane. This scenario might explain the inverse relationship between the levels of PFOA in female urine and plasma and the plateau of plasma PFOA in male rats compared to their losses via urine.

Unfortunately, much work remains to be done to explain the gender differences between male and female rats and to determine whether it is relevant to humans. Similarities are possible because the long half-life in humans suggests that they might be more like the male rat than the female rat. There is a broad range of half-lives in human epidemiology studies suggesting a variability in the unbound fraction of PFOA in serum or in human transport capabilities resulting from genetic variations in structures and consequently in function. Genetic variations in human OATs and OATPs are described in a review by Zaïr et al. (2008).

2.6 Toxicokinetic Considerations

2.6.1 PK Models

One of the earliest PK models was done using the post-dosing plasma data from the Butenhoff et al. study (2004b) in cynomolgus monkeys (Andersen et al. 2006). In this study, groups of six monkeys (three per gender per group) were dosed for 26 weeks with 0, 3, 10, and 20 mg/kg PFOA (high-dose =30 mg/kg PFOA for the first 12 days), followed for >160 days after dosing. Metabolism cages were used for overnight urine collection. Since urine specimens could account for only overnight PFOA excretion, the total volume and total PFOA were extrapolated to 24-hour values based on the excretion rate (volume/hour) for the volume collected and the hours of collection.

The Andersen et al. model (2006) was based on the hypothesis that saturable resorption capacity in the kidney would possibly account for the unique half-life properties of PFOA across species and genders. The model structure, shown in Figure 2-3, was derived from a published model for glucose resorption from the glomerular filtrate via transporters on the apical surface of renal tubule epithelial cells (Andersen et al. 2006).

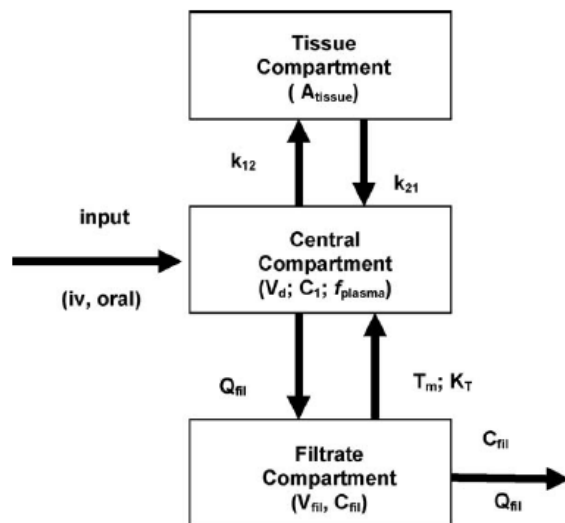

Figure 2-3. Schematic for a Physiologically Motivated Renal Resorptions PK Model

The renal-resorption model includes a central compartment that receives the chemical from the oral dose and a filtrate compartment for the glomerular filtrate from which resorption and transfer to the central compartment can occur. Transfer from the filtrate compartment to the central compartment decreases the rate of excretion. The resorption in the model was saturable, meaning that there was less resorption and greater excretion at high serum PFOA concentrations than at low concentrations.

The model was parameterized using the body weight and urine output of cynomolgus monkeys (Butenhoff et al. 2004b) and a cardiac output of 15 L/h/kg from the literature (Corley et al. 1990). A 20% blood flow rate to the kidney was assumed based on data from humans and dogs. Other parameters were optimized to fit the data for plasma and urine at lower concentrations and then applied for the 20 mg/kg/day dose, which was assumed to represent a concentration at which renal resorption was saturated. Based on the data for the dose of 20 mg/kg/day, the model was able to predict the decline in plasma levels after the cessation of dosing. The predictions were fairly adequate for one of the three modeled monkeys; for the other two monkeys, the model predicted higher levels than were observed. That result could have occurred because the model did not allow for efflux of PFOA into the glomerular filtrate through transporters on the basolateral surface of the tubular cells. The authors observed that three monkeys had faster CL_R of PFOA than the other three monkeys.

Tan et al. (2008) divided the second compartment in the Andersen et al. model (2006) into a liver compartment and a tissue compartment. A storage compartment was added between the filtrate compartment and urinary excretion (Figure 2-4) (Tan et al. 2008).

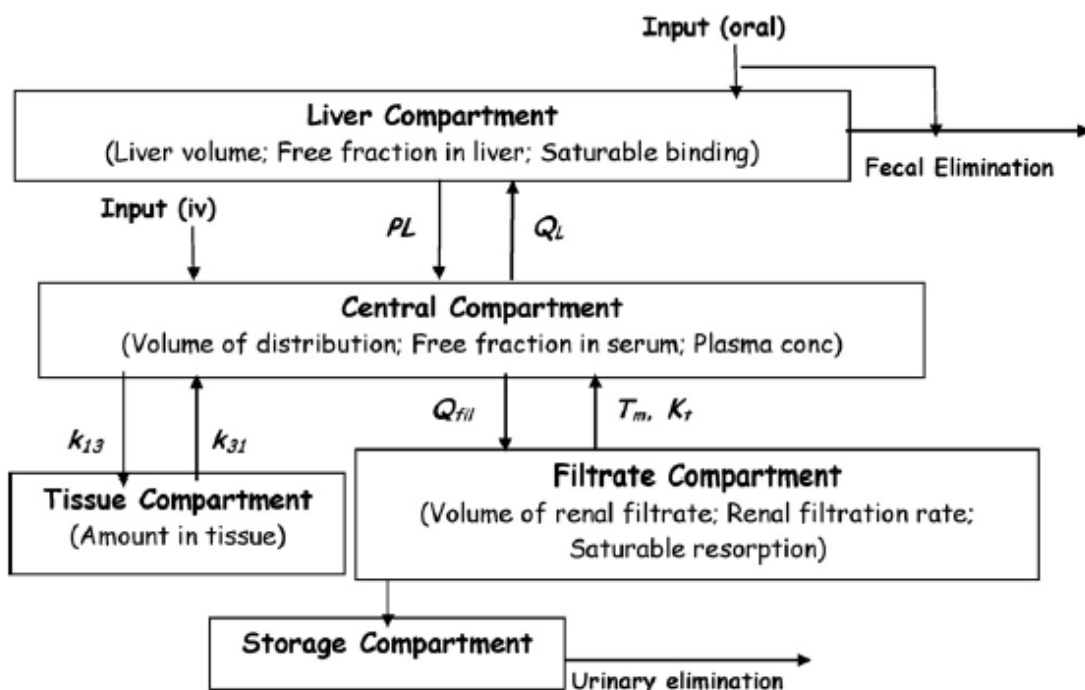

Figure 2-4. Physiologically Motivated Pharmacokinetic Model Schematic for PFOA-Exposed Rats

The models were parameterized and applied to the Kemper data (2003) for male and female CD rats given doses of 1, 5, and 25 mg/kg/day. The model did not provide a satisfactory fit between the predictions of plasma concentration or urine + fecal excretion and experimental data for either gender.

Lou et al. (2009) used the data they collected on the serum, liver, and kidney PFOA concentration (see section 2.2.1) in CD-1 mice to examine if one- or two-compartment PK models would fit the experimental data for 1, 10, and 60 mg/kg/day single gavage doses (see Figure 2-5 for the one-compartment model). Both models assumed first order absorption and elimination. The two-compartment model included a central compartment that received PFOA after absorption and transferred it to a second compartment for excretion. The excretion compartment was coupled with bidirectional flow between the two compartments. The net loss from the central compartment differed during and after distribution. The models were fit using a general nonlinear least squares approach. A likelihood ratio squared approach was applied to determine which model achieved the best fit to the data.

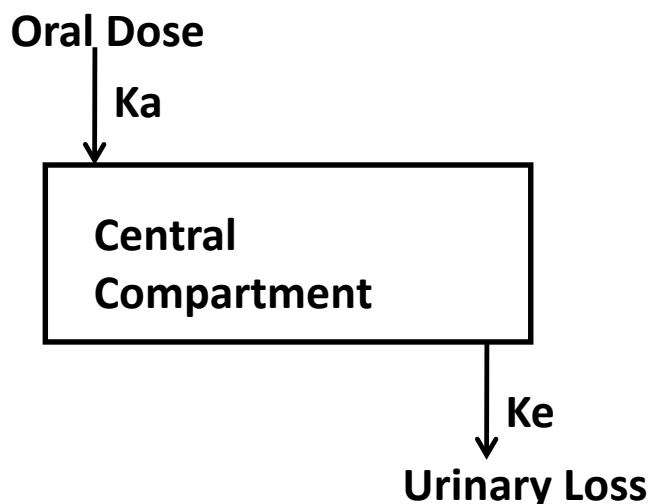

Figure 2-5. Schematic for One-Compartment Model.

The one compartment model performed well for serum, liver, and kidney in this analysis, and output was not significantly improved with use of a two-compartment model. The input parameters for the one-compartment model included V_d , serum half-life, and absorption rate constant (K_a) and elimination rate constant (K_e) for serum, liver, and kidney. There were slight differences in the fitted values between males and females for some parameters. The K_e values were consistently higher in the female mice (Table 2-24). The quantitative measures for liver and kidney were only available for the 1- and 10-mg/kg/day doses.

Table 2-24. Model Parameters for 1 and 10 mg/kg Single Doses of PFOA to CD1 Mice

Tissue	Parameter (abbreviation)	Females	Males
Serum	Volume of distribution (V_d)	0.135 L/kg	0.266 L/kg
	Absorption rate constant (K_a)	0.537 L/hr	
	Elimination rate constant (K_e)	0.00185 L/hr	0.00133 L/hr
	Half-life ($T_{1/2}$)	15.6 days	21.7 days
Liver	Volume of distribution (V_d)	0.161 L/kg	0.120 L/kg
	Absorption rate constant (K_a)	0.5170 L/hr	
	Elimination rate constant (K_e)	0.00161 L/hr	0.00129 L/hr
Kidney	Volume of distribution (V_d)—1 mg/kg	0.822 L/kg	1.280 L/kg
	Volume of distribution (V_d)—10 mg/kg	1.092 L/kg	1.170 L/kg
	Absorption rate constant (K_a)	0.527 L/hr	
	Elimination rate constant (K_e)	0.00151 L/hr	0.00113 L/hr

Source: Lou et al. 2009

The one-compartment model described above was not able to predict serum concentration in female mice given a single 60-mg/kg dose, suggesting a change in kinetics with the 60-mg/kg dose compared to the 1- and 10-mg/kg doses. This conclusion is supported by comparison of the serum measurements made during the 30-day post-dosing period for all three doses. The serum PFOA concentration at the 60-mg/kg dose declined more rapidly with time than serum PFOA concentrations at the 1- and 10-mg/kg doses. For example, a serum concentration of about 0.4 mg/L was reached in about 28 days at the 60-mg/kg dose, 61 days at the 10-mg/kg dose, and 70 days at the 1-mg/kg dose (values estimated from Figure 3, Lou et al. 2009). The one-

compartment model also produced a poor fit for the serum level measurements taken 24 hours after the cessation of a 17-day exposure to 20 mg/kg/day. The two-compartment model provided a better fit with experimental serum concentration data for the single 60-mg/kg dose and the repeat 20-mg/kg/day dose, but the fit was still unsatisfactory.

Lou et al. (2009) also tried the Andersen et al. renal-resorption model (2006) to determine if it provided an improved fit for the data. The Andersen et al. model (2006) fit to the data was superior to that of the one- and two-compartment models of Lou et al. (2009) for the 60-mg/kg single-dose and the 20-mg/kg/day repeat-dose scenarios.

The Andersen et al. model (2006) includes a second tissue compartment that articulates with the central compartment but not the filtrate compartment. In addition to values for V_d , K_a , and K_e , the model includes values for cardiac output, volume for the renal filtrate, renal blood filtration rate, intercompartmental CL, transport maximum, transport affinity constant (K_t), and the proportion of free PFOA in serum. With the exception of body weight and cardiac output, the input parameters for the model were either assumed (i.e., volume of renal filtrate and proportion of free serum PFOA) or optimized for the model. The wide confidence bounds around the optimized values are indicative of considerable parameter uncertainty.

The Lou et al. parameter estimates (2009) indicate that there may be several biological limitations to the Andersen et al. (2006) PK model for adult mice including the fact that it requires an unreasonably high portion of the cardiac output to pass through the kidneys to optimize fit to the experimental data. It also does not include excretion via export transporters in the renal tubular cells or consider that the bound fraction in the serum could vary with the magnitude of the dose and duration of dosing. Much of the emerging data is consistent with a variety of tubular transporters functioning in both efflux and resorption from the glomerular filtrate. In addition, there are opportunities for protein binding within organs that could function to retard distribution to the cytosol, especially at low doses. The binding of PFOA with L-FABP is an example. Once binding sites are saturated, the concentration in the cytosol will increase.

A model also has been developed that applied to female CD-1 mice during gestation and lactation (Rodriguez et al. 2009). The gestational model includes two compartments, one for the dam and the other for the litter. They are linked by placental blood flow. The biological data used to set the parameters for the two compartments were based on the data from the Lau et al. (2006) and Abbott et al. (2007) studies in CD-1 and 129S1/SvImJ mice, respectively. Exposure was assumed to be limited by blood flow, and only the experimental doses that did not impact litter size (i.e., 0.1–1.0 mg/kg/day for CD-1 mice and 1–10 mg/kg/day for 129S1/SvImJ mice) were used in model development.

Lactational exposure was modeled as a dynamic relationship between the dam ($n = 10$) and the litter, and they were connected by a milk compartment. Milk yield information was obtained from the literature. Milk was assumed to be consumed as it was produced without any circadian impact on consumption patterns. PFOA excreted in pup urine was routed back to the dam.

Both absorption and excretion were assumed to be first order processes as was lactation transfer from the dam to the litter (Figure 2-6) (Rodriguez et al. 2009). Resorption of a portion of the PFOA urinary efflux was included in the model. The renal excretion/resorption was parameterized for cardiac output, kidney blood flow, GFR, urine flow rate, volume of renal plasma (fraction of body weight), and volume of renal filtrate (fraction of body weight). The fraction of free PFOA in serum reaching the glomerulus was assumed to be 0.01 based on

protein binding information. As was the case with the Lou et al. model (2009), Rodriguez et al. (2009) did not include parameters to adjust for transporter-mediated efflux from the renal tubular cells into the glomerular filtrate.

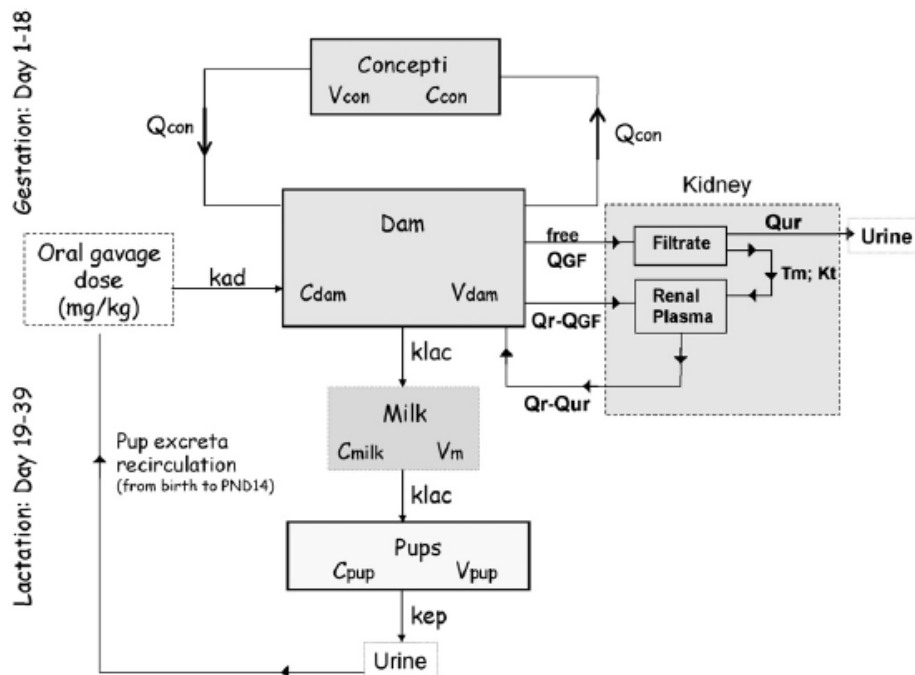

Figure 2-6. PK Model of Gestation and Lactation in Mice

One of the limitations of the Rodriguez et al. modeling effort (2009) was the limited amount of laboratory data against which to evaluate projections. Serum measures from the Lau et al. (2006) and Abbott et al. (2007) studies were available for only a few time points. Nevertheless, the authors reached several conclusions based on the model projections as follows:

- The model had a tendency to overestimate serum levels, suggesting nonlinearity as doses increased.
- Gestation and lactation as a source of exposure contributed about equally to the pups of 129S1/SvImJ dams exposed only during gestation.
- The contributions to the pups from gestation exceeded those from lactation in the CD-1 mice.
- Exposure to the pups via lactation increased over time.
- Lactation is a CL pathway for the dam.

A number of uncertainties accompany the model because of the assumptions regarding the flow limitation on transport to the fetus and to maternal milk: the first order K_e for the pups and, for the milk, the maternal serum partition coefficient and the limited knowledge regarding the renal tubular transporters. They caution that the model should not be applied for cross-species or high-to-low dose extrapolation.

Loccisano et al. (2011) developed a PFOA PBPK model for monkeys based on the Andersen et al (2006) and Tan et al. (2008) models, and then extrapolated it for use in humans (Figure 2-7). The model reflects saturable renal absorption of urinary PFOA by the proximal tubule of

the kidney. This is represented in Figure 2-7 by the interactions between the plasma and kidney plus the interaction of the filtrate compartment with both plasma and kidney.

The fraction of PFOA free in plasma and available for glomerular filtration was based on data fit and estimated to be less than 10% because of binding to serum proteins, especially albumin. Lacking the kinetic data on tubular resorption, the rate was based on the best fit to the plasma/urine data. A storage compartment was added to the model between filtrate and urine. Tissue plasma partition coefficients were derived from the data by Kudo et al. (2007) following the disposition pattern of a single intravenous (IV) dose to male Wistar rats.

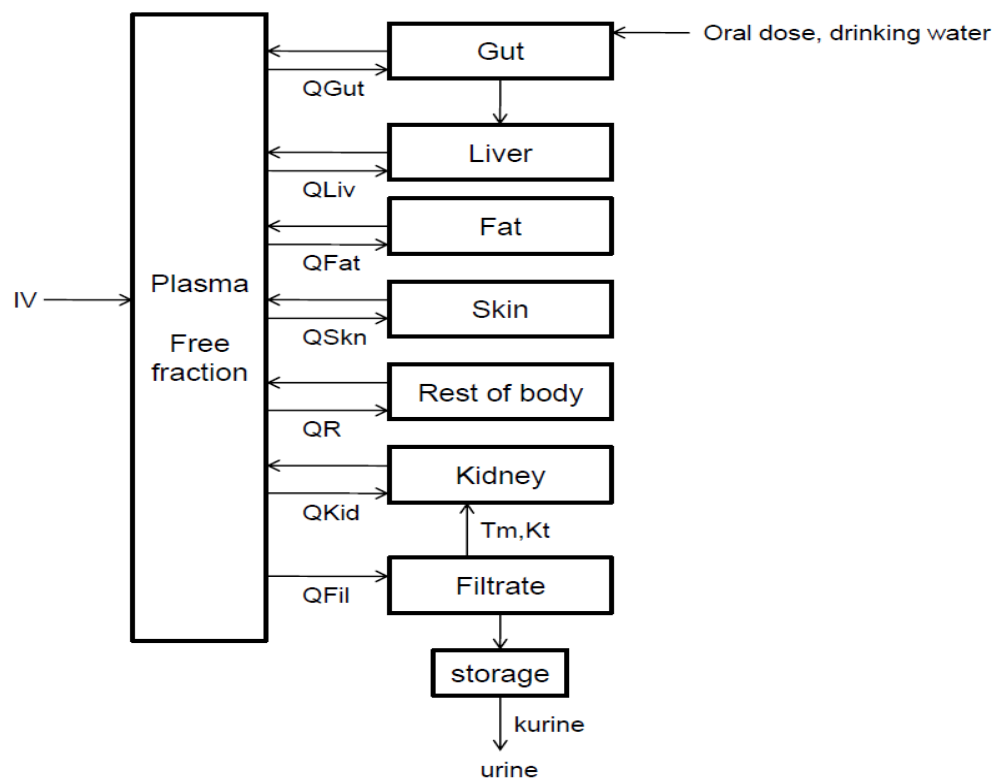

Notes:

T_m = transporter maximum, K_t = affinity constant, and Q = flow in and out of tissues.

Figure 2-7. Structure of the PFOA PBPK Model in Monkeys and Humans

Existing IV and oral data sets from Butenhoff et al. (2004b) for the cynomolgus monkey were used to develop the monkey model. In the oral study (section 2.2.1), animals were dosed for 6 months and followed for 90 days after dosing. Plasma and urine samples were analyzed periodically during dosing and recovery. The model projections for the oral study were in good agreement with the Butenhoff et al. data (2004b) for the 10-mg/kg dose, showing a rapid rise to plasma steady state and a slow terminal half-life. The model performance for the high dose (30/20 mg/kg/day) did not fit as well, partially as a consequence of the observed toxicity with the initial 30 mg/kg/day dose that necessitated cessation of dosing on study day 12, followed by resumption of dosing at 20 mg/kg/day on study day 22.

The structure of the human model was similar to that used for the monkeys. Human serum data (means with standard deviations [SDs] or medians) for PFOA are available for occupational and general populations (Bartell et al. 2010; Calafat et al. 2007a, 2007b; Emmett et al. 2006;

Hölzer et al. 2008; Olsen et al. 2005; Steenland et al. 2009). The fact that the serum data were the results from measurements made following uncertain routes and uncertain exposure durations presented a challenge in the assessment of model fit. The human half-lives used for the model (3.8 and 2.3 years) came from an occupational study (Olsen et al. 2005) and a study of the Little Hocking, Ohio, population after reduction of the PFOA in drinking water as a result of treatment (Bartell et al. 2010). See section 2.6.2. Both half-life values were used in evaluating the model's ability to predict serum concentration at the time the serum samples were collected.

The model produced results that can be characterized as fair to good when compared to the reported average serum measurements. For the Little Hocking population studied by Emmett et al. (2006), the model indicated the need for a 30-year exposure to reach steady-state concentrations. The model indicated that both half-life values provided reasonable results when compared to the measured serum values. The authors concluded that more data are needed on the kinetics of renal transporters and intrahuman variability, plus more definitive information on exposures to further refine the human model.

Fàbrega et al. (2014) adapted the Loccisano et al. model (2011) to include compartments for the brain and lung, and to remove the skin. They applied the adjusted model to humans by using intake and body burden data from residents in Tarragona County, Spain. Food and drinking water were the major sources of exposure. Body burden information came from blood samples from 48 residents; tissue burdens came from 99 samples of autopsy tissues. The adjusted model overpredicted PFOA serum levels by a factor of about 9, the liver by a factor of 4.5, and the kidney by a factor of about 18. Model predictions for PFOS were far more consistent with the tissue concentration experimental data.

The authors also looked at the impact of using data for partition coefficients from human tissues in place of the Loccisano et al. rat data (2011) for the estimation of steady-state tissue concentrations. The PFOA simulation values were closer to the human experimental data when using the human partition coefficient values for the brain and lung, but not for the liver. In the case of the kidney, the simulated projections were generally equivalent with both the human and rat partition coefficients. The authors suggested that both saturable resorption and variations in protein binding are important parameters for PK models. With the exception of serum albumin, the existing models have not considered protein-binding constants within tissues. Even though the use of human partition coefficients improved the steady-state predictions for tissues, overall there were still considerable differences between the experimental values and the predictions with both models.

Loccisano et al. (2012a) also used the saturable resorption hypothesis when developing a model for adult Sprague-Dawley rats (Figure 2-8). The structure of the model is similar to that for the monkey/human model depicted in Figure 2-7, but lacks the fat and skin compartments and includes a storage compartment to accommodate fecal loss of unabsorbed dietary PFOA as well as loss from biliary secretions. Oral and IV data used in model development came from studies by Kemper (2003), Kudo et al. (2007) and Perkins et al. (2004). Partition coefficients for liver:plasma, kidney:plasma, and rest of the body:plasma were derived from unpublished data on mice by DePierre (2009) through personal communication with the authors (Loccisano et al. 2012a). Most of the other kinetic parameters were based on values providing the best fit to the experimental data. Because a number of the renal transporters involved with PFOA resorption are known, available kinetic information was used where appropriate. Model performance was evaluated primarily based on its ability to predict plasma and liver concentrations from the

studies identified above. Performance was generally good given the limitations in the primary data sources, as was the case for the monkey model.

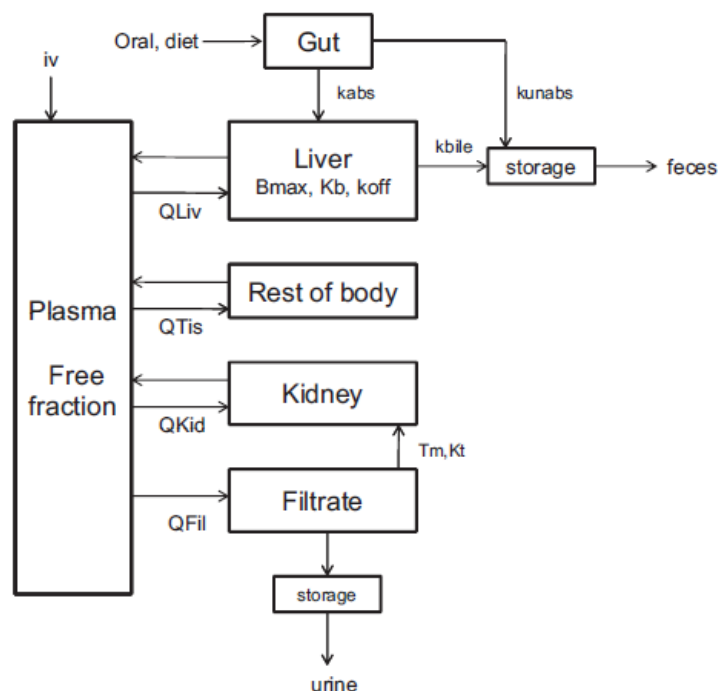

Figure 2-8. Structure of the PBPK Model for PFOA in the Adult Sprague-Dawley Rat

Loccisano et al. (2012b) expanded the adult Sprague-Dawley rat model to cover gestational and lactational exposure to the fetus and pups through their dams. The data from Hinderliter et al. (2005) were used in model development for both the gestation and lactation periods. The gestational model structure for the dams is similar to the model structure shown in Figure 2-8. The model was expanded to include the fetuses linked to the dams by way of the placenta. Uptake from the placenta was described by simple diffusion; the fetal plasma compartment was separate from the dams as was distribution to fetal tissues and amniotic fluid. Based on the transporter data for PFOA, elimination differed for male and female rats and was considered to be developmentally regulated, resulting in faster elimination for female rats than for male rats after sexual maturation. The lactation model linked the pups to their dams through mammary gland secretions. Pup compartments included the gut, liver, kidney, renal filtrate, plasma, and rest of the body.

Model performance was judged by its ability to predict concentrations in maternal and fetal plasma, amniotic fluid, and milk. The predictive capability of the model ranged from fair to good, depending on the medium. The fit of the projections to the data was weakest for the whole embryo during gestation, for which measured levels were greater than projection for two of three data points and for neonate plasma during lactation, for which all data points fell below the predictions.

Loccisano et al. (2013) extended their model development to cover humans during pregnancy and lactation, building on the work done with rodents and recognizing the limitations of the human data available for evaluating the model predictions. Figure 2-9 illustrates the structure of

the model used. The basic structure was derived from the rat model discussed above. Following are some of the key features of the model:

- The fetus is exposed via the placenta through simple bidirectional diffusion.
- Transfer rates to the fetus from the amniotic fluid are governed by bidirectional diffusion.
- Transfer from the fetal plasma to tissues is flow-limited.
- Maternal plasma is directly linked to the milk compartment and considered to be flow-limited; only the free fraction in plasma is transferred to maternal milk.
- The neonate is exposed to PFOA only via maternal milk for the first 6 months postpartum.
- The infant in the model is treated as a single compartment with a V_d .

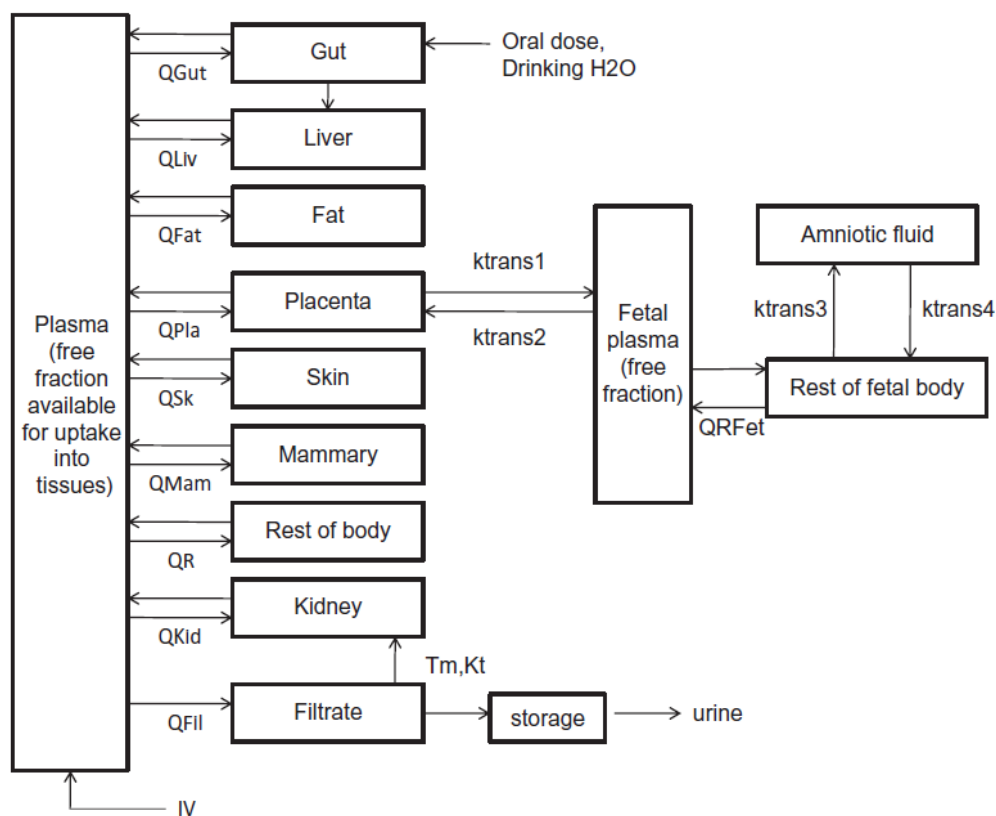

Figure 2-9. PBPK Model Structure for Simulating PFOA and PFOS Exposure During Pregnancy in Humans (Maternal, Left; Fetal, Right)

Limitations to the model are acknowledged and attributed primarily to lack of data to support a more mechanistic approach. Physiological parameters applicable to a pregnant or lactating woman, the fetus, and the nursing infant were obtained from a variety of referenced publications.

To obtain a plasma value at the time of conception, the model was run until it reached a prepregnancy steady-state concentration. The model predicted 30 years as the exposure necessary to reach steady state for the general female population ($1 \text{ E-}4$ to $2 \text{ E-}3 \text{ } \mu\text{g}/\text{kg}$ body weight [bw] /day). The model performance simulations for PFOA were run using an exposure of $1.5 \times 10^{-4} \text{ } \mu\text{g}/\text{kg}$ bw/day. Projections were developed for maternal plasma, fetal plasma, infant plasma, and maternal milk. Agreement between the observed concentrations ($\mu\text{g}/\text{L}$) and the predicted values was considered satisfactory if the predicted value was within 1% of the

observed value. Model output was compared to maternal and fetal plasma values at delivery or at specific time points, and for the infant plasma and milk data where available. Predicted maternal:fetal plasma (cord blood) concentration ratios were more consistent for PFOA than for PFOS when compared to the published data. The projections for fetal internal dose were reasonable, and there was good agreement between the model and the available human lactation data. The modeled maternal plasma was 2.4 µg/L at the time of conception; it slowly decreased across the gestation period and increased slightly at delivery. For the most part, the modeled results fell within ± 1 SD of the observed data.

During lactation, there was a decline in maternal plasma across the 6 months of lactation (a change of 1 µg/L). Thereafter, plasma values slowly increased and stabilized at about 1.5 µg/L at 6 months postpartum. The fetal plasma concentration was about 2.3 µg/L at the start of gestation and declined to about 1.8 µg/L at the time of delivery. Maternal plasma values are about the same as those for the fetus. During the lactation period, the infant plasma increased in a linear fashion to a terminal value of about 5 µg/L. Milk concentrations declined very slightly across the lactation period with an initial concentration of 0.07 µg/L and a final value of 0.05 µg/L. These concentrations were estimated from the graphic data presentation. Breast milk appears to be an important excretory route for the dam.

The projections for PFOA differed from those for PFOS in several respects. Most importantly, maternal and fetal plasma values were similar for PFOA but for PFOS, maternal levels were approximately twofold higher than fetal levels. Compared with PFOS, there was a much greater decline in maternal PFOA plasma values during lactation accompanied by a comparable decline in the PFOA concentration in milk. The increase in infant plasma across the lactation period was comparable for PFOA and PFOS, with the concentration at 6 months postpartum about 2.5 times higher than at 1 month.

Loccisano et al. (2011, 2012a, 2012b, 2013) determined that the human pregnancy lactation model results, when compared to published data, identified the following important research needs:

- Are there differences in the transporter preferences and transfer rates for the individual PFASs? Do those differences correlate with half-life differences?
- Are there qualitative or quantitative differences between the transporters favored by PFOA and those favored by PFOS?
- What physiological factors influence CL for the mother, the fetus, and the infant during gestation and lactation?
- Are placental transport processes active, facilitated, or passive?

These research needs are more pronounced for PFOS than PFOA because the information supporting renal resorption and tissue uptake via membrane transporters for PFOS is very limited. Most models infer that PFOS and PFOA are similar based on their half-lives rather than on published research on PFOS transporter kinetics.

Building on the work of other researchers, Wambaugh et al. (2013) developed and published a PK model to support the development of an EPA RfD for PFOA. The model was applied to data from studies conducted in monkeys, rats, and mice that demonstrated an assortment of systemic, developmental, reproductive, and immunological effects. A saturable renal resorption PK model was used. This concept has played a fundamental role in the design of all of the published PFOA models summarized in this section. In this case, an oral dosing version of the

original model introduced by Andersen et al. (2006) and summarized early in section 2.6.1 was selected for having the fewest number of parameters that would need to be estimated. A unique feature of the Wambaugh et al. approach was to use a single model for all species in the toxicological studies to examine the consistency in the average serum values associated with effects and with no effects from nine animal studies of PFOA. The model structure is depicted in Figure 2-3, with minor modifications.

Wambaugh et al. (2013) placed bounds on the estimated values for some parameters of the Andersen et al. model (2006) to support the assumption that serum carries a significant portion of the total PFOA body load. The Andersen et al. model is a modified two-compartment model in which a primary compartment describes the serum and a secondary deep tissue compartment acts as a specified tissue reservoir. Wambaugh et al. (2013) constrained the total V_d to a value of not more than 100 times that in the serum. As a result, the ratio of the two volumes (serum versus total) was estimated in place of establishing a rate of transfer from the tissue to serum.

A nonhierarchical model for parameter values was assumed. Under this assumption, a single numeric value represents all individuals of the same species, gender, and strain. The gender assumption was applied to monkeys and mice while male and female rats were treated separately because of the established gender-related toxicokinetic differences. Body weight, number of doses, and magnitude of the doses were the only parameters to vary. In place of external doses, serum concentrations as measured at the time of euthanasia were used as the metric for dose magnitude. Measurement errors were assumed to be log-normally distributed. Table 2-25 provides the estimated and assumed PK parameters applied in the Wambaugh et al. model (2013) for each of the species evaluated.

The PK data that supported the analysis were derived from two PFOA PK *in vivo* studies. The monkey PK data were derived from Butenhoff et al. (2004b), and the data for the rats (M/F) were from Kemper (2003). Two strains of female mice were analyzed separately, with CD1 information derived from Lou et al. (2009) and C57Bl/6 information derived from DeWitt et al. (2008). The data were analyzed within a Bayesian framework using Markov Chain Monte Carlo sampler implemented as an R package developed by EPA to allow predictions across species, strains, and genders and to identify serum levels associated with the NOAEL and LOAEL external doses. The model chose vague, bounded prior distributions on the parameters being estimated, allowing them to be significantly informed by the data. The values were assumed to be log-normally distributed, constraining each parameter to a positive value.

The model predictions were evaluated by comparing each predicted final serum concentration to the serum value in the supporting animal studies. The predictions were generally similar to the experimental values. There were no systematic differences between the experimental data and the model predictions across species, strain, or gender, and median model outputs uniformly appeared to be biologically plausible despite the uncertainty reflected in some of the 95th percentile credible intervals. The application of the model outputs in deriving a human RfD is the focus of section 4.0 of this document.

Table 2-25. Pharmacokinetic Parameters from Wambaugh et al. (2013) Meta-Analysis of Literature Data

Parameter	Units	CD1 Mouse (f) ^a	C57Bl/6 Mouse (f) ^a	Sprague-Dawley Rat (f) ^a	Sprague-Dawley Rat (m) ^a	Cynomolgus Monkey (m/f) ^a
bw ^b	kg	0.02	0.02	0.20 (0.16 – 0.23)	0.24 (0.21 – 0.28)	7 (m), 4.5 (f)
Cardiac Output ^c	L/h/kg ^{0.74}	8.68	8.68	12.39	12.39	19.8
k_a	L/h	290 (0.6 – 73,000)	340 (0.53 – 69,000)	1.7 (1.1 – 3.1)	1.1 (0.83 – 1.3)	230 (0.27 – 73,000)
V_{cc}	L/kg	0.18 (0.16 – 2.0)	0.17 (0.13 – 2.3)	0.14 (0.11 – 0.17)	0.15 (0.13 – 0.16)	0.4 (0.29 – 0.55)
k_{12}	L/h	0.012 (3.1 x e ⁻¹⁰ – 38,000)	0.35 (0.058 – 52)	0.098 (0.039 – 0.27)	0.028 (0.0096 – 0.08)	0.0011 (2.4 x e ⁻¹⁰ – 35,000)
$R_{V2.V1}$	Unitless	1.07 (0.26 – 5.84)	53 (11 – 97)	9.2 (3.4 – 28)	8.4 (3.1 – 23)	0.98 (0.25 – 3.8)
T_{maxc}	μmol/h	4.91 (1.75 – 2.96)	2.7 (0.95 – 22)	1.1 (0.25 – 9.6)	190 (5.5 – 50,000)	3.9 (0.65 – 9,700)
K_T	μmol	0.037 (0.0057 – 0.17)	0.12 (0.033 – 0.24)	1.1 (0.27 – 4.5)	0.092 (3.4 x e ⁻⁴ – 1.6)	0.043 (4.3 x e ⁻⁵ – 0.29)
Free	Unitless	0.011 (0.0026 – 0.051)	0.034 (0.014 – 0.17)	0.086 (0.031 – 0.23)	0.08 (0.03 – 0.22)	0.01 (0.0026 – 0.038)
Q_{filc}	Unitless	0.077 (0.015 – 0.58)	0.017 (0.01 – 0.081)	0.039 (0.014 – 0.13)	0.22 (0.011 – 58)	0.15 (0.02 – 24)
V_{filc}	L/kg	0.00097 (3.34 x e ⁻⁹ – 7.21)	7.6 x e ⁻⁵ (2.7 x e ⁻¹⁰ – 6.4)	2.6 x e ⁻⁵ (2.9 x e ⁻¹⁰ – 28)	0.0082 (1.3 x e ⁻⁸ – 7.6)	0.0021 (3.3 x e ⁻⁹ – 6.9)

Notes:

Means and 95% confidence interval (in parentheses) from Bayesian analysis are reported. For some parameters, the distributions are quite wide, indicating uncertainty in that parameter (i.e., the predictions match the data equally well for a wide range of values).

m = male, f = female

^a Data sets modeled for the CD1 mouse were from Lou et al. (2009), for the C57Bl/6 mouse were from DeWitt et al. (2008), for the rat were from Kemper (2003), and for the monkey from Butenhoff et al. (2004b).

^b Estimated average body weight for species used except with Kemper study (2003) where individual rat weights were available and assumed to be constant.

^c Cardiac outputs obtained from Davies and Morris (1993).

2.6.2 Half-Life Data

Human. There have been several studies of half-lives in humans and all support a long residence time for serum PFOA with estimates measured in years rather than months or weeks. Bartell et al. (2010) determined an average half-life of 2.3 years based on a study of the decreases in human serum levels after treatment of drinking water for PFOA removal was instituted by the Lubeck Public Services District in Washington, West Virginia, and the Little Hocking Water Association (LHWA) in Ohio. Source waters for these systems had become contaminated with PFAS from the DuPont Works Plant in Washington, West Virginia, between 1951 and 2000.

The Bartell et al. study (2010) was based on a series of serum measurements (eight over 4 years) from 200 individuals who agreed to participate in the study. Inclusion criteria for the participants included: serum PFOA concentrations ≥ 50 ng/mL, residential water service provided by one of the two treatment plants, never employed at the DuPont plant, not growing their own vegetables, and signed acceptance of the study consent form. The participants were almost equally divided between males and females with an average age of about 50 years (range of 18–89 years). Most of the participants consumed public tap water (172) as their primary source, but a small number (28) consumed bottled water as their source.

The participants were required to report that they primarily used home tap water for cooking, bathing, and showering for the years between 2005 and 2007. The tap water users had to report public water as their primary source of residential water consumption, and bottled water users had to report the use of bottled water as their primary source of residential water consumption. The initial blood draw for serum occurred in June 2007, with subsequent samples at 1, 2, 3, 6, and 12 months after the initial sample. Samples were analyzed by the Centers for Disease Control and Prevention. Nineteen samples from the 2-month blood draw were not analyzed due to mislabeling.

A linear mixed model was used to determine the decline in serum PFOA concentration over time. With these models, the decline from baseline by the participants was essentially first order. The serum PFOA concentration was the only time-varying measurement entered into the model. Serum concentrations were log-normally distributed, as described by the following equation:

$$\ln C = \ln C_0 - kt$$

where:

- C = serum concentration at time t
- C_0 = baseline serum concentration
- k = elimination rate constant
- t = time point for the measurement

The results of this assessment showed a 26% decrease in PFOA concentration per year after adjustment for covariates and a half-life of 2.3 years [confidence interval (CI) = 2.1-2.4]. The covariates considered included the water treatment system, the time exposed before and after filtration, public versus bottled water, gender, age, consumption of local or homegrown vegetables, and exposure to the public water supply at work. The only potential confounders determined to be significant were the treatment plant ($p = 0.03$) and homegrown vegetable consumption ($p < 0.001$).

Identification of consumption of homegrown vegetables as a significant confounder revealed a weakness in the study design because it had been an exclusion factor, yet was identified as an exposure source at the 12-month interview of the study participants. The researchers concluded that this problem was a result of the way the exclusion question was phrased for the original interview, “Do you grow your own vegetables?” When the question was asked later in the study, it was rephrased, “Do you eat any fruits and vegetables grown at your own home?” Some people who answered “no” to the original questions answered “yes” to the second question.

Changes in the source of drinking water during the study could also have impacted the results. When baseline interview data were compared with the results from the 12-month interview, 39% of the bottled water group reported using public water at home. Some of the public water drinkers (10%) reported using primarily bottled water at the 6-month interview.

In another study, the drinking water supply was contaminated with a mixture of perfluorinated chemicals when a soil-improver mixed with industrial waste was applied upriver to agricultural lands in Arnsberg, Germany (Brede et al. 2010). The PFOA levels in the finished drinking water were measured as 500–640 ng/L in 2006. PFOS and PFHxS also were present. The plasma PFOA levels in the Arnsberg population were 4.5 to 8.3 times higher than those in a reference community at the time the problem was discovered. Charcoal filtration was added to the potable treatment train and succeeded in reducing concentrations in the drinking water.

The authors used the differences in plasma 2008 PFOA measurements from a subset of the participants (children and adults) initially exposed in 2006 to determine the PFOA half-life. The 2008 subjects included 66 males, females, and children from Arnsberg and 73 from the reference community in the evaluation. The drinking water concentration monitoring results (nondetects estimated as one-half of the limit of detection [LOD], 10 ng/L) and DWI estimates obtained by questionnaire and interview were used to estimate PFOA exposures. Plasma PFOA samples were collected during a 2-month period in late 2008. Plasma PFOA had declined in the serum for both the Arnsberg residents (39.2%) and those from the reference community (13.4%). In Arnsberg, the decrease was greater for the exposed females and children than for the males when compared to the reference community, an observation that appeared to reflect the reported lower DWIs of the Arnsberg females and children (0.3 ± 0.2 and 0.8 ± 0.6 L/day compared to 0.7 ± 0.5 and 1.6 ± 0.8 L/day, respectively). The estimate for the human half-life was 3.26 years (geometric mean; range 1.03–14.67 years). Regression analysis of the data also suggested that the elimination rate might have been greater in younger subjects and older subjects.

Seals et al. (2011) determined half-life estimates for 602 residents of Little Hocking, Ohio, and 971 residents of Lubeck, West Virginia, who were part of the C8 study but had relocated to a different area of the country. The half-life estimate was based on the decline in serum PFOA levels after the time of the initial measurement and the years since the change in residential location occurred. A background estimate (5 ng/mL) was subtracted from the serum measurements before analysis. On average, the initial serum PFOA concentrations were higher in Little Hocking (60.6 ng/mL) than in Lubeck (31.0 ng/mL). Due to the nonlinearity in scatter plots of the natural log for adjusted serum PFOA concentrations versus the years elapsed since relocation, the authors used a two-segment linear spline regression approach in their analysis of the data (i.e., Little Hocking—4 years, Lubeck—9 years). The slope of the line decreased for the second time segment compared to the first. In former residents of Little Hocking, a -21.4%-change in serum PFOA was observed in the first 4 years after leaving Little Hocking, and a -7.6%-change was observed beyond 4 years. In former Lubeck residents, the serum PFOA change was -7.8% for the first 9 years and 0.2% (a slight increase) afterwards. The half-life estimates for Little Hocking ranged from 2.5–3.0 years (average 2.9 years) and for Lubeck ranged from 5.9–10.3 years (average 8.5 years).

Based on their analysis, the authors suggested that, if their assumptions were correct, a simple first order elimination model might not be appropriate for PFOA given that the rate of elimination appeared to be influenced by both concentration and time. There was a difference in the CL for the two locations even though the range of years elapsed since relocation was the same for both communities. The authors identified three potential limitations of their analysis: the cross-sectional design, the assumption that exposure was uniform within a water district, and a potential bias introduced by exclusion of individuals with serum values <15 ng/mL.

3M (Burriss et al. 2000, 2002) conducted a half-life study on 26 retired fluorochemical production workers from their Decatur, Alabama, (n = 24) and Cottage Grove, Minnesota, (n = 3) plants. Blood was collected from the subjects between 1998 and 2004, a period during which serum samples were drawn every 6 months over a 5-year period, depending on the facility at which the subject had worked. Responses on questionnaires determined whether any of the retirees had occupational exposures after retirement. The average number of years that participants worked was 31 (range 20–36 years) and they had been retired an average of 2.6 years at study initiation (range 0.4–11.5 years). The mean age of the retirees was 61 years (range 55–75) at the beginning of the study.

The initial mean serum PFOA concentration of all of the subjects was 0.691 µg/ml (range 0.072–5.1 µg/mL). At the completion of the study, the mean PFOA concentration was 0.262 µg/mL (range 0.017–2.435 µg/mL). Two of the retirees died during the study period; therefore, they were only followed for 4.2 years. The mean serum elimination half-life of PFOA in these workers was 3.8 years (1378 days, 95% CI, 1131-1624 days) and the median was 3.5 years (Olsen et al. 2005). The range was 1.5–9.1 years (561–3334 days). No association was reported between the serum elimination half-life and with initial PFOA concentrations, age, or gender of the retirees, the number of years retired or working at the production facility, or medication use or health conditions.

Harada et al. (2005) studied the relationship between age, gender, and serum PFOA concentration in residents of Kyoto, Japan. They found that females in the 20–50-year-old age group (all with regular menstrual cycles) had serum PFOA concentrations that were significantly lower than those in females over age 50 (all postmenopausal). Mean serum PFOA concentration in the younger females was 7.89 ± 3.61 ng/ml versus 12.63 ± 2.42 ng/mL in the older females. This age difference in serum PFOA concentrations was not seen in males, and serum PFOA concentrations in males were comparable to those of the older females.

Harada et al. (2005) also estimated the CL_R rate of PFOA in humans and found it to be only about 0.001% of the GFR. There was no significant difference in CL_R of PFOA with respect to gender or age group, and the mean value was 0.03 ± 0.013 ml/day/kg.

Animal. Kemper (2003) examined the plasma concentration profile of PFOA following gavage administration in sexually mature Sprague-Dawley rats. Male and female rats (four per gender per group) were administered single doses of PFOA by gavage at DRs of 0.1, 1, 5, and 25 mg PFOA/kg. After dosing, plasma was collected for 22 days in males and 5 days in females. Plasma concentration versus time data were then analyzed using noncompartmental PK methods (see Table 2-26 and Table 2-27). To further characterize plasma elimination kinetics, animals were given oral PFOA at a rate of 0.1 mg/kg, and plasma samples were collected until PFOA concentrations fell below quantitation limits (extended time).

Plasma elimination curves were linear with respect to time in male rats at all dose levels. In males, plasma elimination half-lives were independent of dose level and ranged from approximately 138 hours to 202 hours. To further characterize plasma elimination kinetics, particularly in male rats, animals were given oral PFOA at a dose of 0.1 mg/kg, and plasma samples were collected until PFOA concentrations fell below quantitation limits (2,016 hours in males). The estimated plasma elimination half-life in this experiment was approximately 277 hours (11.5 days) in male rats.

Plasma elimination curves were biphasic in females at the 5-mg/kg and 25-mg/kg dose levels. In females, terminal elimination half-lives ranged from approximately 2.8 hours at the lowest dose to approximately 16 hours at the high dose. The estimated plasma elimination half-life in the extended time experiment was approximately 3.4 hours in females.

Table 2-26. PK Parameters in Male Rats Following Administration of PFOA

Parameter	Dose					
	0.1 mg/kg	1 mg/kg	5 mg/kg	25 mg/kg	1 mg/kg (IV)	0.1 mg/kg extended time
T _{max} (hr)	10.25 (6.45)	9.00 (3.83)	15.0 (10.5)	7.5 (6.2)	NA	5.5 (7.0)
C _{max} (µg/mL)	0.598 (0.127)	8.431 (1.161)	44.75 (6.14)	160.0 (12.0)	NA	1.08 (0.42)
Lambda z (1/hr)	0.004 (0.001)	0.005 (0.001)	0.0041 (0.0007)	0.0046 (0.0012)	0.004 (0.000)	0.0026 (0.0007)
T _{1/2} (hr)	201.774 (37.489)	138.343 (31.972)	174.19 (28.92)	157.47 (38.39)	185.584 (19.558)	277.10 (56.62)
AUC _{INF} (hr µg/mL)	123.224 (35.476)	1194.463 (215.578)	6733.70 (1392.83)	25,155.61 (7276.96)	1249.817 (113.167)	206.38 (59.03)
AUC _{INF} /D (hr µg/mL/mg/kg)	1096.811 (310.491)	1176.009 (206.316)	1221.89 (250.28)	942.65 (284.67)	1123.384 (100.488)	2111.28 (586.77)
Cl _p (mL/kg/hr)	0.962 (0.240)	0.871 (0.158)	0.85 (0.21)	1.13 (0.31)	0.896 (0.082)	0.51 (0.17)

Source: Kemper 2003

Notes:

Mean (SD)

AUC_{INF}: area under the plasma concentration time curve, extrapolated to infinity; AUC_{INF}/D: AUC_{INF} normalized to dose; Cl_p: plasma clearance; C_{max}: maximum plasma concentration; Lambda z: terminal elimination constant; T_{1/2}: terminal elimination half-life; T_{max}: time to C_{max}.

Table 2-27. PK Parameters in Female Rats Following Administration of PFOA

Parameter	Dose					
	0.1 mg/kg	1 mg/kg	5 mg/kg	25 mg/kg	1 mg/kg (IV)	0.1 mg/kg extended time
T _{max} (hr)	0.56 (0.31)	1.13 (0.63)	1.50 (0.58)	1.25 (0.87)	NA	1.25 (0.50)
C _{max} (µg/mL)	0.67 (0.07)	4.782 (1.149)	20.36 (1.58)	132.6 (46.0)	NA	0.52 (0.08)
Lambda z (1/hr)	0.231 (0.066)	0.213 (0.053)	0.15 (0.02)	0.059 (0.037)	0.250 (0.047)	0.22 (0.07)
T _{1/2} (hr)	3.206 (0.905)	3.457 (1.111)	4.60 (0.64)	16.22 (9.90)	2.844 (0.514)	3.44 (1.26)
AUC _{INF} (hr µg/mL)	3.584 (0.666)	39.072 (10.172)	114.90 (11.23)	795.76 (187.51)	33.998 (7.601)	3.34 (0.32)
AUC _{INF} /D (hr µg/mL/mg/kg)	31.721 (5.880)	38.635 (10.093)	20.78 (2.01)	29.54 (6.92)	30.747 (6.759)	34.39 (3.29)
Cl _p (mL/kg/hr)	32.359 (6.025)	27.286 (7.159)	48.48 (4.86)	35.06 (.88)	34.040 (9.230)	29.30 (3.06)

Source: Kemper 2003

Note: Mean (SD)

Gibson and Johnson (1979) administered a single dose of ¹⁴C-PFOA averaging 11.4 mg/kg by gavage to groups of three male 10-week-old CD rats. The elimination half-life of ¹⁴C from the plasma was 4.8 days. NRC ([2005], cited in Butenhoff et al. [2004b]) reported half-lives of 4–6 days for male rats and 2–4 hours for female rats; there was no mention of the strains studied.

Kemper (2003) reported half-lives of 6–8 days for male Sprague-Dawley rats (Table 2-26) and 3–16 hours for females (Table 2-27).

Lou et al. (2009) determined values of 21.7 days (95% confidence interval: 19.5–24.1) for male CD1 mice and 15.6 days (95% confidence interval: 14.7–16.5) for females for use in their pharmacokinetic model (see section 2.6.1). NRC ([2005], cited in Butenhoff et al. [2004b]) provided values of 12 days for males and 20 days for females without any information on strains.

Butenhoff et al. (2004b) looked at the elimination half-life in monkeys treated for 6 months with 0, 3, 10, and 20 mg/kg/day via capsules. Elimination of PFOA from serum after cessation of dosing was monitored in recovery monkeys from the 10- and 20-mg/kg dose groups. For the two monkeys exposed to 10 mg/kg, serum PFOA elimination half-life was 19.5 ($R^2=0.98$) days and indicated first-order elimination kinetics. For three monkeys exposed to 20 mg/kg, serum PFOA elimination half-life was 20.8 days ($R^2=0.82$) and also indicated first-order elimination kinetics, although dosing was suspended at different time points because of weight loss. The data from NRC (2005), which were provided by Butenhoff et al. (2004b), were about 21 days for females and 30 days for males.

2.6.3 Volume of Distribution Data

Several researchers have attempted to characterize PFOA exposure and intake in humans through PK modeling (Lorber and Egeghy 2011; Thompson et al. 2010). As an integral part of model validation, the parameter for V_d of PFOA within the body was calibrated from the available data. In the models discussed below, V_d was defined as the total amount of PFOA in the body divided by the blood or serum concentration.

Two groups of researchers defined a V_d of 170 ml/kg body weight for humans for use in a simple, single compartment, first-order PK model (Lorber and Egeghy 2011; Thompson et al. 2010). The models developed by these groups were designed to estimate intakes of PFOA by young children and adults (Lorber and Egeghy 2011) and the general population of urban areas on the east coast of Australia (Thompson et al. 2010). In both models, the V_d was calibrated using human serum concentration and exposure data from the NHANES and assumes that most PFOA intake is from contaminated drinking water. Thus, in using the models to derive an intake from contaminated water, the V_d was calibrated so that model prediction of elevated blood levels of PFOA matched those seen in residents.

Butenhoff et al. (2004b) calculated a V_d from noncompartmental PK analysis of data from cynomolgus monkeys. Three males and three females were administered a single IV dose of 10 mg/kg, and serum PFOA concentrations were measured in samples collected up to 123 days post-dosing. The V_d of PFOA at steady state ($V_{d,ss}$) were similar for both genders at 181 ± 12 ml/kg for males and 198 ± 69 ml/kg for females.

2.6.4 Toxicokinetic Summary

Uptake and egress of PFOA from cells is largely regulated by transporters in cell membranes. It is absorbed from the gastrointestinal tract as indicated by serum measurements in humans and treated animals. In serum, PFOA is electrostatically bound to albumin occupying up to nine to twelve sites and sometimes displacing other substances that normally would occupy a site. Linear PFOA chains display stronger binding than branched chains. PFOA binding causes a

change in the conformation of serum albumin, altering its ability to bind with some endogenous and exogenous materials it normally transports.

PFOA is distributed to tissues by a process requiring membrane transporters. Accordingly, the tissue levels vary from organ to organ. The highest tissue concentrations are usually in the liver. Liver accumulation in males is greater than in females. Other tissues with a tendency to accumulate PFOA are the kidneys, lungs, heart, and muscle, plus the testes in males and uterus in females. Post-mortem studies in humans have found PFOA in liver, lungs, bone, and kidneys, but only low levels in brain. PFOA is not metabolized, thus, any effects observed in toxicological studies are the result of parent compound, not metabolites.

Electrostatic interactions with proteins are an important toxicokinetic feature of PFOA. Studies demonstrate binding or interactions with membrane receptors (e.g., PPAR α , T3), transport proteins, and enzymes. Saturable renal resorption of PFOA from the glomerular filtrate via transporters in the kidney tubules is a major contributor to the long half-life of this compound. Branched-chain PFOAs are less likely to be resorbed than the linear molecules based on half-life information in humans. All toxicokinetic models for PFOA are built on the concept of saturable renal resorption first proposed by Andersen et al. (2006). Some PFOA is removed from the body with bile, a process that also is transporter-dependent. Accordingly, the levels in fecal matter represent both unabsorbed material and that discharged with bile.

During pregnancy, PFOA is present in the placenta and amniotic fluid in both animals and humans. Post-delivery, PFOA is transferred to offspring through lactation in a dose-related manner. Maternal serum levels decline as those in the pups increase. This also occurs in humans as demonstrated in a study of females breast-feeding their infants in Little Hocking, Ohio.

The half-life in humans for occupationally exposed workers was 3.8 years (95% CI, 1.5-9.1). The average half-life was 2.3 years among people in the Lubeck Public Services District in West Virginia and the LHWA in Ohio, based on changes in serum levels for the general population after treatment of drinking water was implemented. This half-life value reflects humans whose exposure came primarily from their public water system. Half-lives from animals included 21 days (females) and 30 days (males) for monkeys Butenhoff et al. (2004b); 11.5 days (males) and 3.4 hours (females) in Sprague-Dawley rats (Kemper 2003); and 27.1 days (male) and 15.6 days (female) CD1 mice (Lau et al. 2006). The gender difference between male and female rats is not seen in mice. In early life, the half-lives are nearly the same for both genders of rats, but once the animals reach sexual maturity, resorption increases in males, prolonging the half-life (Hinderliter 2004; Hundley et al. 2006). This change appears to be under the control of hormones in both males and females (Cheng et al. 2006; Kudo et al. 2002).

3 HAZARD IDENTIFICATION

This section provides a summary and synthesis of the data from a large number of human epidemiology studies accompanied by studies in laboratory animals designed to identify both the dose response and critical effects that result from exposures to PFOA and to examine the MoA leading to toxicity.

3.1 Human Studies

Epidemiology studies of effects of PFOA have been conducted in three types of populations: workers exposed in chemical plants producing or using PFOA, high-exposure communities (i.e., an area in West Virginia and Ohio that experienced water contamination over a period of more than 20 years), and general population studies with background exposures. These populations differ with respect to exposure levels. The approximate range in serum PFOA concentrations is 0.010–> 2.0 (means around 1–4 µg/mL) in the PFOA-exposed workers, and 0.010–0.100 µg/mL and below LOD to < 0.010 µg/mL in the high-exposure community and general population settings, respectively. Although moderate-to-high correlations between PFOA and PFOS are often seen in general populations ($r > 0.5$), the correlation is lower in the West Virginia and Ohio high-exposure area ($r=0.3$). In evaluating and synthesizing results from these studies, it is important to consider differences in the exposure range within the study population and the exposure level within the referent group, as differences (or inconsistencies) can be expected depending on the shape of the exposure-response curve and the exposure range encompassed by different studies. In addition, the optimal choice of an exposure metric (e.g., cumulative or a time-specific) depends on the specific outcome being examined.

Occupational studies. Large-scale production of PFOA occurred in the United States for several decades. Both 3M (in Alabama and Minnesota) and DuPont (in West Virginia) have been the primary U.S. producers and users of perfluorinated compounds, and both companies have offered voluntary fluorochemical medical surveillance programs to workers at plants that produced or used perfluorinated compounds. The monitoring data collected by 3M and DuPont were used in conjunction with mortality and health effects information in a number of epidemiology studies of cancer and noncancer outcomes in the worker populations. 3M discontinued manufacturing PFOA in 2000, but a subsidiary in Europe (Antwerp, Belgium) continued to manufacture and sell it through 2008.

High-exposure community studies. Members of the general population living in the vicinity of the DuPont Washington Works PFOA production plant in Parkersburg, West Virginia, are the focus of a large-scale, community-based study titled the C8 Health Project. Releases from the Washington Works plant, where PFOA (C8) was used as a processing aid in the manufacture of fluoropolymers, contaminated the ground water of six water districts near the plant resulting in exposures to the general population. The plant began production in the 1950s, with PFOA use and emission from the plant increasing in the 1980s. Study participants from the affected areas ($n = 69,030$; 33,242 males, 35,788 females; <10–70+ years) were identified in 2005–2006, and a series of studies were conducted. The participants all received compensation and provided a blood sample and filled out an extensive questionnaire that included information on drinking water sources, use of home-grown produce, and health information. A variety of approaches to exposure assessment have been used in these studies, with the most detailed incorporating individual residential history and water consumption and source data, emissions data,

environmental characteristics, water pipe installation, PK data, and workplace exposures (Barry et al. 2013; Shin et al. 2011; Vieira et al. 2013). The methods allow the estimation of cumulative and of current exposure at different time periods or ages for individual study participants. Details of the specific analyses undertaken to estimate historical exposures and to ascertain different types of outcomes (retrospective and prospective analyses) are described in detail below. Drinking water concentrations were based on PFOA releases from the DuPont plant and residential address history of the participants (C8 Science Panel 2012).

The C8 Health Project also involved a review of evidence of health effects, considering their own studies and studies conducted by others and in other populations. The conclusions for each health endpoint assessed—“probable link” or “not a probable link”—are available on the C8 Science Panel website in a series of reports completed in 2011–2012 (see <http://www.c8sciencepanel.org/index.html>).

General population studies. Studies investigating the association between PFOA levels and health effects in the U.S. general population have been conducted using the NHANES data set. NHANES examined representative members of the U.S. population (~5000 adults and children/year) through surveys focusing on different health topics. The study consists of an interview (demographic, socioeconomic, dietary, and medical questions) and examination (medical including blood and urine collection, and dental and physiological parameters). Biomonitoring included a number of PFAS, predominantly PFOA and PFOS.

A study by Jain (2014) examined the influence of diet and other factors on the levels of serum PFOA and other PFAS using NHANES 2003–2004, 2005–2006, and 2007–2008 data. Significantly higher serum PFOA levels were found in males (0.0047 µg/mL) than in females (0.035 µg/mL) and in smokers (0.043 µg/mL) than in nonsmokers (0.040 µg/mL). No significant differences in PFOA serum concentration were seen during the time periods evaluated. There was a positive association of PFOA with increases in serum cholesterol ($p < 0.001$), serum albumin ($p < 0.001$), and body mass index (BMI) ($p < 0.04$) based on the 5,591 records used in the assessment. Intakes of nonalcoholic beverages were positively associated with serum PFOA ($P < 0.001$), but no associations were found for other dietary food groupings.

The results of these studies along with other population studies are described in the following sections. In the studies of worker cohorts, the data collected focused on measures of cardiovascular risk, signs of organ damage, standard hematological endpoints, and cancer (primarily cancer-related mortality). Within the general population, data were focused on cardiovascular risk factors and diabetic or prediabetic conditions as well as reproductive and developmental endpoints. The following summary focuses on measures of lipids (e.g., cholesterol, LDL); liver, kidney, and thyroid effects; reproductive effects (e.g., pregnancy-related outcomes, specifically pregnancy-related hypertension and preeclampsia, measures of fetal growth, and pubertal development); and cancer (specifically kidney and testicular cancer). These outcomes were selected either because of the availability of studies in a variety of settings with some indications of effects (e.g., as noted in the C8 Science Panel reports), or to allow comparison with results from studies in animals. Summary tables are included to support evaluation of the weight of evidence and facilitate comparison of the serum concentrations in the epidemiology studies to those in the animals studies summarized in section 3.2.

3.1.1 Noncancer

3.1.1.1 Serum Lipids and Cardiovascular Diseases

Serum Lipids

Occupational studies. Four cross-sectional studies are described in this section and in Table 3-1. Olsen et al. (2000) analyzed data from voluntary medical surveillance examinations of PFOA production workers at a 3M plant in 1993, 1995, and 1997. Cholesterol, LDL, HDL, and triglycerides were measured in male workers (n = 111 in 1993, n = 80 in 1995, and n = 74 in 1997). Multivariable regression analyses, conducted separately by year (cross-sectional), were adjusted for age, BMI, alcohol consumption, and cigarette use. Employees' serum PFOA levels were stratified into three categories—<1, 1- <10, and ≥10 µg/mL. The sample size in the highest category ranged from 11 to 15 in the three examination years. There was little variation by exposure category in mean or median TC, LDL, HDL, or triglycerides across the workers in 1993, 1995, or 1997.

Olsen and Zobel (2007) examined data from the 2000 medical surveillance program at the three 3M plants, which is an expanded and refined analysis of the data reported in Olsen et al. (2003). The fluorochemical workers consisted of males (age 21–67) from the Antwerp, Belgium (n = 196); Cottage Grove, Minnesota (n = 122); and Decatur, Alabama (n = 188) production facilities who volunteered to participate in the medical surveillance program and did not take cholesterol-lowering medication. Blood was collected for fluorochemical concentration determination and serum lipid parameters including cholesterol, LDL, HDL, and triglycerides. Analysis of variance (ANOVA), analysis of covariance, logistic regression, and multiple regression models were used to analyze the data with age, BMI, and alcohol consumption as covariates. Potential associations with PFOS levels were not evaluated because a previous analysis had shown no association between PFOS and the selected outcomes. Serum PFOA concentrations ranged from 0.01 to 92.03 µg/mL for the male workers (all sites combined), with a mean serum PFOA concentration of 2.21, 1.02, 4.63, and 1.89 µg/mL for all sites combined, and the Antwerp, Cottage Grove, and Decatur sites, respectively. Serum PFOA (all sites combined) was not associated with TC or LDL. A negative association was observed between serum PFOA concentration (all sites combined) and HDL. Serum triglyceride was positively associated with serum PFOA at all sites combined and independently at the Antwerp site. Nonadherence to the fasting requirement for blood collection, especially for night-shift workers, and potential binding of PFOA to albumin and LDL, were identified by the authors as possible factors that influenced the triglyceride results.

Sakr et al. (2007a) conducted a cross-sectional analysis of PFOA and lipids among active employees at the DuPont Washington Works fluoropolymer production plant in West Virginia. The employees who volunteered to participate in the study (n = 1025, 782 males, 243 females) each had a physical examination, provided a fasting blood sample, and answered a medical and occupation history questionnaire in 2004. The association between PFOA and lipid levels was evaluated by ANOVA, χ^2 test, student's t-test, and linear regression models. Confounders including age, BMI, gender, alcohol consumption, and parental heart attack were considered in the models. Mean serum PFOA concentration in the workers was 0.428 ± 0.189 µg/mL (interquartile range 0.099–0.381). For those with current occupational exposure to PFOA, the range was 0.0174–9.55 µg/mL and for workers with intermittent occupational exposure, the range was 0.0081–2.07 µg/mL. The range was 0.0086–2.59 µg/mL for workers with past occupational exposure and the 0.0046–0.963 µg/mL for workers with no occupational exposure.

Serum PFOA was positively associated with cholesterol, very low-density lipoprotein (VLDL), and LDL ($p < 0.03$) in the participating workers, whether or not they were taking lipid-lowering medication. No association was observed between serum PFOA and HDL or triglycerides. PFOS was not included in the study.

Costa et al. (2009) examined serum lipid data using 30 years of medical surveillance data from workers of a PFOA production plant in Italy. The workers ($n = 53$ males, 20–63 years of age) participated in the medical surveillance program yearly from 1978 to 2007. The length of work exposure was 0.5–32.5 years. In 2007, 37 males were active workers and 16 males were retired or had transferred to other departments and were no longer being exposed. Unexposed male workers ($n = 107$, 12 executives and 95 blue collar workers) from different departments also participated in the medical surveillance program and served as controls. Beginning in 2000, serum PFOA was monitored yearly except in 2005. Serum PFOA concentrations in the workers decreased after plant renovations partially automated the PFOA production process and procedures for the use of protective devices were instituted in 2002. In 2007, the geometric mean serum PFOA was 4.02 and 3.76 $\mu\text{g/mL}$, respectively, in currently exposed and retired workers. Three analyses were conducted: a t-test comparing 34 exposed workers matched to 34 unexposed workers by age, work seniority, day/shift work, and living conditions; linear regression with 34 exposed workers and 107 unexposed workers adjusting for age, work seniority, BMI, smoking, and alcohol consumption; and a repeated measures analysis with a total of 56 individuals with more than one measure, adjusting for age, work seniority, BMI, smoking, alcohol consumption, and year of observation. TC and uric acid were significantly increased ($p < 0.05$) in relation to PFOA exposure in each of these analyses. No correlations were observed between serum PFOA concentration and Apo-A (HDL-associated) or Apo-B (LDL-associated) proteins, HDL, or triglycerides in any of the analyses. PFOS was not included in this study.

Three other studies included analyses with multiple measures over time (Table 3-1). Olsen et al. (2003) conducted a longitudinal analysis of the 2000 medical surveillance data from the 3M workers in conjunction with 1995 and 1997 data. This analysis included 175 male employees with data from 2000 and at least one of the other survey dates. Only 41 employees were participants in all three surveillance periods. Mean serum levels for the group sampled in 1995 and 2000 ($n = 64$) were 1.36 $\mu\text{g/mL}$ and 1.59 $\mu\text{g/mL}$, respectively. Mean serum levels for the group sampled in 1997 and 2000 ($n = 69$) were 1.22 $\mu\text{g/mL}$ and 1.49 $\mu\text{g/mL}$, respectively. Finally, mean serum levels for the group sampled in 1995, 1997, and 2000 ($n = 41$) were 1.41 $\mu\text{g/mL}$, 1.90 $\mu\text{g/mL}$, and 1.77 $\mu\text{g/mL}$, respectively. When serum levels were analyzed using a repeated measures mixed-model multivariable regression, adjusting for age, BMI, smoking, alcohol consumption, location, year at first entry, years worked (at baseline), and years of follow-up, there was a statistically significant positive association between PFOA and serum cholesterol (Beta¹ = 0.032, 95% CI 0.013, 0.015) and triglycerides (Beta = 0.094, 95% CI 0.045, 0.144) ($p = 0.0002$). PFOS levels were not associated with changes in serum lipids over time.

Sakr et al. (2007b) conducted a longitudinal analysis among the workers at the DuPont Washington Works plant in West Virginia using data from 1979 to 2004. Employee medical records from the medical surveillance program were used to obtain blood lipid (e.g., TC, LDL, HDL, triglycerides), height, and weight data. As part of the medical surveillance program, each employee gave a detailed medical history and had a physical examination at least every 3 years. Serum PFOA concentration was measured every 1–2 years in PFOA-exposed workers and every

¹ The beta coefficient from the regression analysis.

3–5 years in non-PFOA-exposed workers on a volunteer basis. This study included 454 workers who had two or more serum PFOA measurements. The study population included 334 males and 120 females ranging in age from 24 to 66 years who had worked at the plant for at least 1 year since 1979. A linear mixed effects regression model was used to analyze the data and accounted for age (and age-squared), gender, BMI, and decade of hire as potential confounders. Serum PFOA concentrations ranged from 0 to 22.66 µg/mL, with a mean of 1.13 µg/mL over the 23-year monitoring period in the study population. For employees with two or more PFOA measurements, the mean of the first and last sample was 1.04 µg/mL and 1.16 µg/mL, respectively, with an average of 10.8 years between samples. Serum PFOA concentration was positively associated with TC after age, BMI, gender, and decade of hire adjustment in the model (Beta = 1.06, 95% CI 0.24, 1.88) per ppm increase in PFOA. Information on lipid-lowering medications and alcohol intake by the participants was not available. PFOS was not included in this study.

Steenland et al. (2015) conducted an analysis of the incidence of several conditions, including high cholesterol (based on prescription medication use) among 3,713 workers at the Washington Works plant in West Virginia who participated in the C8 Health Project. Yearly serum estimates were modeled from work history information and job-specific concentrations. Cox proportional hazard models, stratified by birth year, were used to assess self-reported incidence of high cholesterol in relation to time-varying cumulative estimated PFOA serum concentration, controlling for gender, race, education, smoking, and alcohol consumption. No association was seen when analyzed without a lag (HRs by quartile 1.0, 1.11, 1.06, 1.05; trend $p = 0.56$ for log cumulative exposure), or when using a 10-year lag (HRs by quartile 1.0, 0.93, 1.01, 0.96; trend $p = 0.62$).

High-exposure community studies. Several studies examined serum lipids in populations serviced by water districts contaminated by the Washington Works PFOA production plant in Ohio and West Virginia (Table 3-2). Emmett et al. (2006) is a small study ($n = 371$) with limited analysis (t-tests comparing PFOA levels in people with abnormal versus normal TC); the larger studies were conducted as part of the C8 Health Project. This collection of studies includes analyses of current serum PFOA levels in relation to serum lipids in adults (Steenland et al. 2009) and children (Frisbee et al. 2010), longitudinal analysis of the change in lipids seen in relation to a change in serum PFOA (Fitz-Simon et al. 2013), and analyses of the incidence of hypercholesterolemia in relation to modeled exposure (Winquist and Steenland 2014a). With the exception of one set of analyses within the Winquist and Steenland study (2014a), these data provide consistent evidence of positive associations between PFOA exposure (measured directly in blood or modeled based on environmental and drinking water data) and TC.

Emmett et al. (2006) examined the association of serum PFOA concentration with serum TC in residents of the Little Hocking water district in Ohio. The study population ($n = 371$, 2–>60 years of age) was a random sample of the population served by LHWA. The subjects completed questionnaires (e.g., demographic, occupational, health conditions, and so forth) and provided blood samples. PFOA concentration was determined by HPLC/MS/MS; no other PFASs were measured. Regression models were used to analyze the data. The median serum PFOA concentration was 0.354 µg/mL. No association was observed between serum PFOA and TC.

Steenland et al. (2009) examined the association of PFOA with serum lipids in adult participants of the C8 Health Project ($n = 46,294$; 18–≥80 years). Serum samples were separated into deciles or quartiles for analysis. TC, HDL, triglycerides, LDL, and non-HDL (TC minus HDL cholesterol) were measured or calculated from blood samples. The data were analyzed by linear regression using the log-transformed values for all variables. Covariates of the model

included age, gender, quartile BMI, education, smoking, regular exercise, and alcohol consumption. A logistic model was used to analyze high cholesterol and serum PFOA concentration (quartiles). The mean serum PFOA concentration was 0.080 µg/mL. All lipid outcomes, except for HDL, showed significant increasing trends with increasing serum PFOA decile. There was a positive association between mean levels of serum PFOA and TC, LDL cholesterol, triglycerides, TC/HDL ratio, and non-HDL. The predicted increase in TC from lowest to highest serum PFOA concentration decile was 11–12 milligrams per deciliter (mg/dL). The odds ratio (OR) for high cholesterol (≥ 240 mg/dL) increased from the lowest to the highest quartile of serum PFOA concentrations: 1.00, 1.21 (95% CI: 1.12–1.31), 1.33 (95% CI: 1.23–1.43), and 1.38 (95% CI: 1.28–1.51). No association was observed between mean level of serum PFOA and HDL cholesterol. PFOS also was positively associated with TC, LDL cholesterol, and triglycerides. The results of the study were consistent with occupational studies that found a positive association between PFOA exposure and serum lipids.

The study by Frisbee et al. (2010) used a design and analysis strategy similar to that of Steenland et al. (2009), but it was conducted among children (n = 6536; 1–11.9 years) and adolescent (n = 5934; 12.0–17.9 years) participants of the C8 Health Project. The mean serum PFOA concentration was 0.0777 µg/mL and 0.0618 µg/mL, respectively, for children and adolescents. TC, LDL, and triglycerides were positively associated ($p \leq 0.02$) with serum PFOA concentration, adjusting for age, gender, BMI, exercise, and length of fast. Assessment of the quintile trends showed significant differences ($p \leq 0.02$) between the first and fifth quintile for TC and LDL for children and adolescents of both genders combined and separated. A significant difference ($p = 0.04$) was observed for fasting triglycerides in female children only. An increased risk of abnormal TC and LDL were positively associated with serum PFOA. The ORs were 1.0 first (reference), 1.1 (95% CI: 1.0–1.3, second), 1.2 (95% CI: 1.0–1.4, third), and 1.2 (95% CI: 1.1–1.4, fourth and fifth) for TC, and 1.0 (reference, first), 1.2 (95% CI: 1.0–1.5, second), 1.2 (95% CI: 1.0–1.4, third and fourth), and 1.4 (95% CI: 1.2–1.7, fifth) for LDL. An increased risk of abnormal fasting triglyceride and HDL was not associated with serum PFOA. PFOS also was positively associated with TC, LDL cholesterol, and HDL cholesterol.

The C8 Science Panel (2012) used data from the C8 general population cohorts as well as from combined general population and worker cohorts to evaluate the association between PFOA and a medical diagnosis of high cholesterol. Despite inconsistent evidence between studies, they concluded that there is a probable link between PFOA and diagnosed high cholesterol. The worker cohort was not evaluated separately in this analysis.

A cohort of 521 members of the C8 Health Project was evaluated for an association between changes in serum PFOA levels and changes in serum LDL-cholesterol, HDL-cholesterol, TC, and triglycerides over a 4.4-year period (Fitz-Simon et al. 2013). Linear regression models were fit to the logarithm (base 10) of ratio change in each serum lipid measurement in relation to the logarithm of ratio change in PFOA. Mean serum PFOA concentration decreased by approximately one-half between baseline (0.140 ± 0.209 µg/mL) and follow-up (0.068 ± 0.144 µg/mL). No corresponding changes in serum lipids were found. However, those individuals with the greatest declines in serum PFOA had a larger decrease in LDL cholesterol.

Table 3-1. Summary of PFOA Occupational Exposure Studies of PFOA and Serum Lipids

Reference and Study Details	PFOA Level	TC	LDL	HDL	Triglycerides
<i>Cross-sectional</i>					
Olsen et al. 2000 n = 111 in 1993, 80 in 1995, 74 in 1997; 50-70% participation rate Mean age: ~ 40 yrs Mean duration: not reported ANOVA based on three exposure categories, adjusted	(1) 0 to < 1, mean ~ 0.4 µg/mL (2) 1 to < 10, mean ~ 3 µg/mL (3) ≥ 10, mean ~ 30 µg/mL	1993: mean 215, 219, 232 mg/dl (p = 0.45) 1995: mean 207, 212, 221 mg/dl (p = 0.48) 1997: mean 199, 213, 217 mg/dl (p = 0.08)	1993: mean 138, 143, 140 mg/dl (p = 0.84) 1995: mean 131, 133, 130 mg/dl (p = 0.96) 1997: mean 114, 134, 134 mg/dl (p = 0.11)	1993: mean 43, 47, 48 mg/dl (p = 0.32) 1995: mean 42, 43, 41 mg/dl (p = 0.70) 1997: mean 41, 44, 45 mg/dl (p = 0.40)	1993: mean 171, 205, 221 mg/dl (p = 0.77) 1995: mean 152, 123, 183 mg/dl (p = 0.07) 1997: mean 219, 176, 251 mg/dl (p = 0.13)
Olsen and Zobel 2007 3M. Antwerp, Cottage Grove, Decatur combined; 50-65% participation rate n = 506 (men, not taking lipid-lowering medications) Mean age: 40 yrs Mean duration: not reported Linear regression, adjusted [Related reference: Olsen et al. 2003]	Mean 2.21 µg/mL range 0.01–92.03 µg/mL	Beta = 0.0076 (SE 0.0059) (p = 0.20) [log-transformed PFOA and cholesterol]	Beta = 0.0021 (SE 0.0090) (p = 0.81) [log-transformed PFOA and cholesterol]	Beta = -0.0183 (SE 0.0069) (p = 0.01) [log-transformed PFOA and cholesterol]	Beta = 0.0711 (SE 0.0169) (p = 0.0001) [log-transformed PFOA and cholesterol]
Sakr et al. 2007a Washington Works (West Virginia) n = 1025 (782 men, 243 women), 55% participation rate Mean age: 46.5 and 44.4 yrs, respectively for men and women Mean duration: 19.6 and 15.9 yrs, respectively for men and women Linear regression, adjusted	Mean 0.428 µg/mL range 0.005– 9.55 µg/mL	All: Beta = 4.036 (SE 1.284) (p = 0.002) Excluding workers taking lipid-lowering medications: Beta = 5.519 (SE 1.467) p = < 0.001	All: Beta = 2.834 (SE 1.062) (p = 0.008) Excluding workers taking lipid-lowering medications: Beta = 3.561 (SE 1.213) (p = 0.003)	All: Beta = -0.178 (SE 0.432) (p = 0.68) Excluding workers taking lipid-lowering medications: Beta = 0.023 (SE 0.058) (p = 0.96)	All: Beta = 0.18 (SE 0.021) (p = 0.38) Excluding workers taking lipid-lowering medications: Beta = 0.030 (SE 0.024) (p = 0.21) [TG log-transformed]
Costa et al. 2009 Italy PFOA production plant n = 37 currently exposed, 16 formerly exposed, 107 controls (different areas in the plant) Mean age: 42 yrs—currently exposed and controls; 52 yrs—formerly exposed Mean duration (in 2007): 14-16 yrs Analysis 1: t-test, 34 currently exposed matched to 34 controls, adjusted Analysis 2: Linear regression, 34 currently exposed and 107 controls, adjusted Analysis 3: linear regression (generalized estimating equation [GEE] modeling), 56 total with concurrent PFOA and lipid measure, adjusted	Currently exposed: mean 12.9, geometric mean 4.02, range 0.2–47 µg/mL Formerly exposed: mean 6.81 geometric mean 3.76, range 0.53–18 µg/mL	Analysis 1: Currently exposed: 237.0 mg/dl Controls: 206.4 mg/dl (p = 0.003) Analysis 2: Beta = 21.7 (95% CI 6.83, 36.6) (p = 0.005) Analysis 3: Beta = 0.028 (95% CI 0.002, 0.055) (p < 0.05)	Not measured	Analysis 1: Currently exposed: 56.68 mg/dl Controls: 57.82 mg/dl (p => 0.05) Analysis 2: Beta = 2.42 (95% CI -2.30, 7.13) (p > 0.05) Analysis 3: Beta = -0.018 (95% CI -0.047, 0.012) (p > 0.05)	Analysis 1: Currently exposed: 150.03 mg/dl Controls: 155.35 mg/dl (p > 0.05) Analysis 2: Beta = -0.15 (95% CI -34.6, 34.3) (p > 0.005) Analysis 3: Beta = 0.055 (95% CI -0.036, 0.147) (p > 0.05)

Reference and Study Details	PFOA Level	TC	LDL	HDL	Triglycerides
<i>Longitudinal</i>					
Olsen et al. 2003 3M, Antwerp and Decatur combined ~5 yr follow-up period n = 174 (measure in 1995 or 1997, and in 2000) Mean age: not reported Mean duration: not reported Linear mixed effects regression for repeated measures, adjusted	1995 baseline: 1.36-1.41 µg/mL 2000 follow-up: 1.49-1.77 µg/mL	Beta = 0.032 (95% CI 0.013, 0.051) [and statistically significant PFOA-years follow-up interaction, Beta = -0.0004]	Not measured	Reported as “no significant changes”	Beta = 0.094 (95% CI 0.045, 0.144)
Sakr et al. 2007b Washington Works (West Virginia) n = 454 23-yr follow-up (mean 3.7 PFOA measures) Mean age: 27 yrs (at hire) Mean duration: 27 yrs Linear mixed effects regression for repeated measures, adjusted	1.04 µg/mL (first) 1.16 µg/mL (last) Declined since 1980 (mean 4.78 µg/mL in 1980 to 1.00 µg/mL in 2001–2004)	Beta = 1.06 (95% CI 0.24, 1.88)	Beta = 0.46 (95% CI -0.87, 1.79)	Beta = 0.16 (95% CI -0.39, 0.71)	Beta = 0.79 (95% CI -5.99, 7.57)
Steenland et al. 2015 n=3,713 workers Data collected in 2005-2006 and 2008-2011 n=1,298 cases	In 2005-2006: mean 0.325 µg/mL, median 0.113 µg/mL	HR (95% CI), for self-reported use of cholesterol-lowering medications (incidence based on year of diagnosis). Cumulative exposure quartile, no lags: 1.00 (referent) 1.11 (0.94, 1.30) 1.06 (0.89, 1.27) 1.05 (0.87, 1.27) (<i>P</i> _{trend} = 0.56)			

Table 3-2. Summary of High-Exposure Community Studies of PFOA and Serum Lipids

Reference and Study Details	PFOA level	TC	LDL	HDL	Triglycerides
<i>Cross-sectional</i>					
Emmett et al. 2006 n = 371, aged 2–89 yrs, median 50 yrs (317 from stratified random population sample) Linear regression (continuous PFOA) and t-test, PFOA, abnormal versus normal cholesterol	0.354 µg/mL	Regression: Beta = 0.00551 (p = 0.27) p-value of t-test = 0.79 [n = 182, 49% abnormal]	Not measured	Not measured	Not measured
Steenland et al. 2009 n = 46,294, aged 18-80 yrs (not taking cholesterol-lowering medications) Linear regression, quartiles PFOA and continuous PFOA	Mean 0.08 µg/mL Quartiles 0- 0.0131 0.0132-0.0265 0.0266-0.0669 ≥ 0.067	Beta = 0.01112 (SE 0.00076) [log PFOA and lipids] By quartiles (OR): 1.0 (referent) 1.21 (1.12, 1.31) 1.33 (1.23, 1.43) 1.38 (1.28, 1.50)	Beta = 0.01499 (SE 0.00121) [log PFOA and lipids]	Beta = 0.00276 (SE 0.00094) [log PFOA and lipids]	Beta = 0.00169 (SE 0.00219) [log PFOA and lipids]
Frisbee et al. 2010 6,536 children 1-< 12 yrs 5,934 adolescents, 12-18 yrs Linear regression, adjusted	Mean µg/mL Children 0.0777 Adolescents 0.0618	Difference between 1 st and 5 th quintile PFOA (trend p): Children 5.8 mg/dl (p < 0.0001) Adolescents 4.2 mg/dl (p < 0.0001)	Difference between 1 st and 5 th quintile PFOA (trend p): Children 4.9 mg/dl (p = 0.001) Adolescents 3.2mg/dl (p = 0.004)	Difference between 1 st and 5 th quintile PFOA (trend p): Children 5.8 mg/dl (p = 0.88) Adolescents 4.2 mg/dl (p = 0.20)	Difference between 1 st and 5 th quintile PFOA (trend p): Children 2.0 mg/dl (p = 0.10) Adolescents 3.8 mg/dl (p = 0.10)
<i>Longitudinal (Change in Lipid in Relation to Change in PFOA)</i>					
Fitz-Simon et al. 2013 Longitudinal; 4.4 yrs n = 521 Linear regression of log of ratio change in serum lipid to log of ratio change in PFOA, adjusted for age, gender, interval between measures, fasting status (change in lipid in relation to change in PFOA)	0.140 µg/mL (baseline) 0.068 µg/mL (follow-up)	Percent decrease (95% CI) in lipid per halving PFOA: 1.65 (0.32, 2.97); with additional adjustment for PFOS: 0.63 (-0.88, 2.12)	Percent decrease (95% CI) in lipid per halving PFOA: 3.58 (1.47, 5.66); with additional adjustment for PFOS: 2.92 (0.71, 5.09)	Percent decrease (95% CI) in lipid per halving PFOA: 1.33 (-0.21, 2.85); with additional adjustment for PFOS: 1.24 (-0.34, 2.79)	Percent decrease (95% CI) in lipid per halving PFOA: -0.78 (-5.34, 3.58); with additional adjustment for PFOS: -1.16 (-5.85, 3.33)
<i>Incidence of Hypercholesterolemia</i>					
Winquist and Steenland 2014a n = 32,254 (including 3,713 workers) Data collected in 2005-2006 and 2008-2011 n = 9,653 cases in primary analysis (all diagnoses) n = 1,825 cases in prospective analysis (diagnoses after 2005-2006)	In 2005-2006: mean 0.0866 µg/mL, median 0.0261 µg/mL	HR (95% CI), self-reported use of cholesterol-lowering medications, primary analysis Cumulative exposure quintiles: Year exposure quintiles: 1.00 (referent) 1.00 (referent) 1.24 (1.15, 1.33) 1.07 (1.01, 1.15) 1.17 (1.09, 1.26) 1.11 (1.04, 1.19) 1.19 (1.11, 1.27) 1.05 (0.99, 1.13) 1.19 (1.11, 1.28) (<i>P_{trend}</i> = 0.005) 1.20 (1.12, 1.28) (<i>P_{trend}</i> = 0.001)			
Diagnoses after 2005: no association with PFOA with either exposure metric					

More recently, participants in the C8 Health Project were examined for an association between PFOA levels and incidence of several conditions, including high cholesterol (based on prescription medication use) (Winquist and Steenland 2014a). The cohort included 28,541 community members and 3,713 workers who had completed study questionnaires during 2008–2011. The median serum PFOA level at enrollment in 2005–2006 was 0.0261 µg/mL for the combined cohort, 0.0242 µg/mL for the community members, and 0.1127 µg/mL for the workers. Retrospective serum levels for the community cohort were estimated from air and water concentrations, residential history, and water consumption rates. For the workers, yearly serum estimates were modeled from work history information and job-specific concentrations. Cox proportional hazard models, stratified by birth year, were used to assess self-reported adult heart disease hazard in relation to time-varying yearly or cumulative (sum of yearly estimates) estimated PFOA serum concentration, controlling for gender, race, education, smoking, and alcohol consumption. Using the cumulative exposure metric, the HRs for hypercholesterolemia for quintiles 2–5 versus quintile 1 were 1.24, 1.17, 1.19, and 1.19 ($P_{trend} = 0.005$). Using the yearly exposure metric, the HRs for high cholesterol for quintiles 2–5 versus quintile 1 were 1.07, 1.11, 1.05, and 1.20 ($P_{trend} = 0.001$). The strongest association was in males aged 40–59. No associations were found between PFOA level and hypertension or coronary artery disease incidence. (The analysis of these data restricted to the worker population by Steenland et al. [2015] is described in the previous section).

A subset of 290 individuals in the C8 Health Project was evaluated for evidence that PFOA exposure can influence the transcript expression of genes involved in cholesterol metabolism, mobilization, or transport (Fletcher et al. 2013). RNA was extracted from whole blood samples taken from 144 males and 146 females aged 20–60 years; serum collected at the same time was used to measure PFOA concentration. The association between candidate gene expression levels and PFOA levels was assessed by multivariable linear regression with adjustments for confounders. Inverse associations were found between PFOA levels and expressions of transcripts involved in cholesterol transport (NR1H2, NPC1, and ABCG1; $p = 0.002$, 0.026, and 0.014, respectively). When genders were analyzed separately, PFOA was negatively associated with expression of genes involved in cholesterol transport in males (NPC1, ABCG1, PPAR α) and females (NCEH1). Similar associations were found with PFOS.

General population studies. Several studies examined serum lipids in the general population (Table 3-3). Nelson et al. (2010) examined the relationship between polyfluoroalkyl chemical serum concentration, including PFOA, and lipid and weight outcomes in the general population of the United States by analyzing data from the 2003–2004 NHANES. The population ($n = 860$) included persons aged 20–80 years with no missing covariate information who were not pregnant, breast-feeding, taking insulin or cholesterol medicine, or undergoing dialysis. Cholesterol (TC, HDL, LDL) was measured from serum samples. Data for covariates predicting cholesterol and body weight including age, gender, race/ethnicity, socioeconomic status, saturated fat intake, exercise, alcohol consumption at ≥ 20 years of age, smoking, and parity were obtained from the questionnaires. Regression analyses were performed for gender and the age groups 12–19 years, 20–59 years, and 60–80 years. The mean PFOA concentration was 0.0046 ± 0.003 µg/mL. A positive association was found between TC and non-HDL (TC-HDL, ~70–80% TC) cholesterol and serum PFOA (effect estimate 9.8; 95% CI, -0.2–19.7). No association was found between serum PFOA concentration and HDL, or LDL. No association was found between serum PFOA concentration and body weight. Similar results were found with PFOS. A similar analysis using 1999–2008 NHANES data for 815 adolescents (aged 12–18 years) by Geiger et al. (2014a) found an association between serum PFOA and TC

(Beta 4.55, 95% CI 0.90, 8.20, per ln-unit increase in PFOA) and LDL (Beta 5.75, 95% CI 2.16, 9.33, per ln-unit increase in PFOA).

Eriksen et al. (2013) examined the association between plasma PFOA (and PFOS) levels and TC levels in a middle-aged Danish population. This cross-sectional study included 663 males and 90 females aged 50–65 years who were enrolled in the Danish Diet, Cancer and Health cohort. Generalized linear models were used to analyze the association between PFOA and TC levels, adjusted for age, gender, education, BMI, smoking, alcohol consumption, egg intake, animal fat intake, and physical activity. The mean plasma PFOA level was 0.0071 µg/mL. A significant, positive association was found between PFOA (and PFOS) and TC such that, in the fully adjusted model, a 4.4-mg/dL (95% CI 0.8, 8.5) higher concentration of TC was found per interquartile range of plasma PFOA (quartile cut-points were not reported).

Fisher et al. (2013) examined the association of plasma PFAS levels, including PFOA, with metabolic function and plasma lipid levels. This population-based sample included 2,700 participants aged 18–74 years (~50% male) in the Canadian Health Measures Survey. The geometric mean PFOA concentration was 0.0025 ± 0.0018 µg/mL. In analyses that included sampling weights, no associations were found between PFOA (or PFOS) and TC, HDL- and LDL-cholesterol, and metabolic syndrome and glucose homeostasis parameters. Covariates considered included age, gender, marital status, income adequacy, race, education, BMI, physical activity, smoking, and alcohol consumption.

Starling et al. (2014) examined the association between PFOA (and six other PFASs) and serum lipids in pregnant females in the Norwegian Mother and Child Cohort Study. Most of the blood samples were drawn during weeks 14–26 of gestation. Weighted multiple linear regression was used to estimate the association between PFOA level and each lipid level. Covariates considered included age, prepregnancy BMI, nulliparous or interpregnancy interval, breastfeeding duration, education, current smoking, gestation week at blood draw, oily fish consumption, and weight gain during pregnancy. The median plasma PFOA level was 0.00225 µg/mL. No association was observed between PFOA and triglycerides, TC, or LDL-cholesterol. PFOA was positively associated with HDL-cholesterol, although the CI was large for the association. With HDL-cholesterol, each interquartile range- (IQR-) unit increase in ln-PFOA was associated with an increase of 1.28 mg/dL (95% CI: -0.15, 2.71). Five of the seven PFASs studied were positively associated with HDL cholesterol and all seven had elevated HDL associated with the highest quartile.

Table 3-3. Summary of General Population Epidemiology Studies of PFOA with Serum Lipids

Reference and Study Details	PFOA level	TC	LDL	HDL	Triglycerides
<i>All Adults</i>					
Nelson et al. 2010 United States, NHANES (2003–2004) n = 860, aged 20-80 yrs (451 men, 409 women) Linear regression, PFOA in quartiles and continuous PFOA, adjusted PFOA-PFOS correlation Spearman r = 0.65	Mean 0.0046 µg/mL, median 0.0038 µg/mL	Beta = 1.22 (95% CI 0.04, 2.40) 9.8 mg/dl increase in top versus bottom quartile (PFOS results similar)	Beta = -0.21 (95% CI -1.91, 1.49) (PFOS results similar)	Beta = -0.12 (95% CI -0.41, 0.16) Different pattern seen with PFOS	Not measured
Eriksen et al. 2013 Denmark n = 753, aged 50-65 yrs (663 men, 90 women) Linear regression, continuous PFOA, adjusted PFOA-PFOS correlation not reported	Mean 0.0071 µg/mL	4.4 mg/dl increase per IQR (PFOS results similar)	Not measured	Not measured	Not measured
Fisher et al. 2013 Canada, Canadian Health Measures Survey n = 2,700, aged 18-74 yrs Linear regression, continuous PFOA (log-transformed PFOA and lipids) PFOS correlation r = 0.36	Mean 0.0025 µg/mL Quartiles: 0.00015-0.00185 0.00186-0.00258 0.00259-0.00355 ≥ 0.0036	Beta = 0.03 (95% CI -0.017, 0.07) [log PFOA and lipids]	Beta = 0.02 (95% CI -0.06, 0.091) [log PFOA and lipids]	Beta = 0.0009 (95% CI -0.04, 0.04) [log PFOA and lipids]	Not measured
<i>Pregnant Women</i>					
Starling et al. 2014 Norway n = 891 pregnant women Plasma PFOA (collected in 2nd trimester) Linear regression, continuous PFOA (log-transformed PFOA), adjusted PFOS correlation Spearman r = 0.64	Median 0.00225 µg/mL	Beta = 2.58 (95% CI -4.32, 9.47) [per ln-unit increase in PFOA]	Beta = 2.25 (95% CI -3.97, 8.48) [per ln-unit increase in PFOA]	Beta = 2.13 (95% CI -0.26, 4.51) [per ln-unit increase in PFOA]	Beta = 0.00 (95% CI -0.07, 0.06) [per ln-unit increase in PFOA]
<i>Adolescents</i>					
Geiger et al. 2014a United States, NHANES (1999-2008) n = 815, aged 12-18 yrs Linear regression, continuous PFOA (log-transformed PFOA), adjusted	Mean 0.0042 µg/mL	Beta = 4.55 (95% CI 0.90, 8.20) [per ln-unit increase in PFOA] (PFOS results similar)	Beta = 5.75 (95% CI 2.16, 9.33) [per ln-unit increase in PFOA] (PFOS results similar)	Beta = -1.52 (95% CI -3.02, -0.03) [per ln-unit increase in PFOA] Attenuated results when adjusted for PFOS	Beta = 1.74 (95% CI -2.88, 6.36) Different pattern seen with PFOS

The association between PFOA and serum lipids has been examined in several studies in different populations. Cross-sectional and longitudinal studies in occupational settings (Costa et al. 2009; Olsen et al. 2000, 2003; Olsen and Zobel 2007; Sakr et al. 2007a, 2007b; Steenland et al. 2015) and in the high-exposure community (the C8 Health Project study population) (Fitz-Simon et al. 2013; Frisbee et al. 2010; Steenland et al. 2009; Winqvist and Steenland 2014a) generally observed positive associations between serum PFOA and TC in adults and children (aged 1–< 18 yrs); most of the effect estimates were statistically significant. Although exceptions to this pattern are present (i.e., some of the analyses examining incidence of self-reported high cholesterol based on medication use in Winqvist and Steenland [2014a] and in Steenland et al. [2015]), the results are relatively consistent and robust. Similar associations were seen in analyses of LDL, but were not seen with HDL. The range of exposure in occupational studies is large (with means varying between 0.4 and > 12 µg/mL), and the mean serum levels in the C8 population studies were around 0.08 µg/mL. Positive associations between serum PFOA and TC (i.e., increasing lipid level with increasing PFOA) were observed in most of the general population studies at mean exposure levels of 0.002–0.007 µg/mL (Eriksen et al. 2013; Fisher et al. 2013; Geiger et al. 2014a; Nelson et al. 2010; Starling et al. 2014). The interpretation of these general population results is limited, however, by the moderately strong correlations (Spearman $r > 0.6$) and similarity in results seen for PFOS and PFOA.

3.1.1.2 Cardiovascular Diseases

Occupational exposure studies. Several studies examined cardiovascular-related cause of death among PFOA-exposed workers at the West Virginia Washington Works plant (Leonard et al. 2008; Sakr et al. 2009; Steenland and Woskie 2012) and the 3M Cottage Grove plant in Minnesota (Lundin et al. 2009; Gilliland and Mandel 1993). This type of mortality is of interest because of the relation between lipid profiles (e.g., LDL) and the risk of cardiovascular disease. The most recent West Virginia study included 5,791 individuals who had worked at the plant for at least 1 year between 1948 and 2002, with mortality follow-up through 2008. No associations were found between cumulative PFOA levels and ischemic heart disease (IHD) mortality (standardized mortality ratio [SMR] 1.07, 1.02, 0.87, and 0.93 across four quartiles of cumulative exposure, compared to U.S. referent group). Based on these data from the worker cohorts, the C8 Science Panel (2012) concluded that there is no probable link between PFOA and stroke and coronary artery disease.

The analysis of the Minnesota plant ($n = 3,993$ workers who began work between 1983 and 1997, with follow-up through 2002) also found no association between cumulative PFOA exposure and IHD risk, but an increased risk of cerebrovascular disease mortality was seen in the highest exposure category (HR 2.1, 95% CI 1.0, 4.6). These studies are limited by the reliance on mortality (rather than incidence) data, which can result in a substantial degree of under ascertainment and misclassification.

3.1.1.3 Liver Enzymes and Liver Disease

Cross-sectional studies and longitudinal studies of PFOA and liver enzymes in various populations are described in this section and summarized in Table 3-4.

Table 3-4. Summary of Epidemiology Studies of PFOA and Liver Enzymes

Reference and Study Details	PFOA level	Results
Cross-sectional: Occupational Exposure Studies		
Olsen et al. 2000 n = 111 in 1993, 80 in 1995, 74 in 1997; 50-70% participation rate Mean age: ~ 40 yrs Mean duration: not reported ANOVA and linear regression adjusted for age, BMI, and alcohol and cigarette use	Mean (range) µg/mL 1993: 5 (0-80) 1995: 6.8 (0-114) 1997: 6.4 (0.1-81)	ALT: Year β (±SE) (p value) 1993: 0.89 (2.88) (p = 0.76) 1995: 0.81 (2.62) (p = 0.75) 1997: 2.77 (1.27) (p = 0.03) Change per 10 µg/mL increase in serum PFOA; stronger association in individuals with BMI < 30. No associations for ALP, GGT, AST, total bilirubin, direct bilirubin.
Olsen and Zobel 2007 3M. Antwerp, Cottage Grove, Decatur combined; 50-65% participation rate n = 506 (men, not taking lipid-lowering medications) Mean age: 40 yrs Mean duration: not reported Linear regression adjusting for ln age, ln BMI, ln alcohol [Related reference: Olsen et al. 2003]	Mean (range) µg/mL 2.21 (0.01 – 92.03)	β change per ln PFOA (±SE) p value ln ALP: All 0.009 (± 0.008) (p = 0.25) Decatur: 0.08 (0.34) (p = 0.02) ln AST: All -0.005 (± 0.009) (p = 0.55) Decatur: 0.011 (0.02) (p = 0.57) ln ALT: All 0.025 (± 0.013) (p = 0.06) Decatur: 0.08 (0.034) (p = 0.02) ln GGT: All 0.033 (± 0.017) (p = 0.05) Decatur: 0.08 (0.034) (p = 0.02) ln total bilirubin: All -0.033 (± 0.01) (p = 0.001) Decatur: -0.054 (± 0.021) (p = 0.01) Replacement of ln BMI with triglycerides in the model resulted in reduced associations for ALT and GGT.
Sakr et al. 2007a Washington Works (West Virginia) n = 1025 (782 men, 243 women), 55% participation rate Mean age: 46.5 and 44.4 yrs, respectively for men and women Mean duration: 19.6 and 15.9 yrs, respectively for men and women Linear regression, adjusting for age, BMI, alcohol consumption, gender, history of heart attack in parent, use of lipid-lowering medications	0.428 µg/ml LOQ 0.0005 µg/ml range 0.005 – 9.55 µg/mL	β (±SE) p value: Full sample Excluding 178 men on lipid-lowering medications ln AST: 0.012 (± 0.012) (p = 0.317) ln AST: 0.023 (±0.013) (p = 0.079) ln ALT: 0.023 (± 0.015) (p = 0.124) ln ALT: 0.031 (±0.017) (p = 0.071) ln GGT: 0.048 (± 0.02) (p = 0.016) ln GGT: 0.05 (±0.023) (p = 0.03) ln bilirubin: 0.008 (± 0.014) (p = 0.59) ln bilirubin: 0.1 (±0.017) (p = 0.637)
Costa et al. 2009 Italy Cross-sectional 56 male workers (currently and formerly exposed and unexposed) with concurrent serum PFOA and clinical parameters measured in last 7 yrs GEE models adjusting for age, years of exposure, year of PFOA sampling, BMI, smoking, and alcohol consumption	Currently exposed: mean 12.9, geometric mean 4.02, range 0.2-47 Formerly exposed: mean 6.81 geometric mean 3.76, range 0.53-18 µg/mL	β change per µg PFOA/mL (95% CI) AST: 0.038 (-0.003, 0.080) ALT: 0.116 (0.054, 0.177) GGT: 0.177 (0.076, 0.278) ALP: 0.057 (0.007, 0.107) Total bilirubin: -0.080 (-0.137, -0.024) Conj. bilirubin: -0.034 (-0.09, 0.031)

Reference and Study Details	PFOA level	Results
Longitudinal: Occupational Exposure Studies		
Olsen et al. 2003 3M, Antwerp and Decatur combined ~5 yr follow-up period n = 174 (measure in 1995 or 1997, and in 2000) Mean age: not reported Mean duration: not reported Linear mixed effects regression for repeated measures, adjusted	1995 baseline: 1.36-1.41 µg/mL 2000 follow-up: 1.49- 1.77 µg/mL	No associations observed; however, data not provided
Sakr et al. 2007b Washington Works (West Virginia) n = 454 23-yr follow-up (mean 3.7 PFOA measures) Mean age: 27 yrs (at hire) Mean duration: 27 yrs Linear mixed effects regression for repeated measures, adjusted	1.04 µg/mL (first) 1.16 µg/mL (last) Used PFOA measurement from same year as biomarker test or interpolated using two surrounding values	β IU/L change per 1 µg/mL PFOA (95% CI) ALP: (n = 1327) -0.21 (-0.60, 0.18) AST: (n = 1326) 0.35 (0.10, 0.60) ALT: (n = 231) 0.54 (-0.46, 1.54) GGT: (n = 233) 1.24 (-1.09, 3.57) Total bilirubin: (n = 1327) 0.008 (-0.0139, -0.0021)
Cross-sectional: High-Exposure Community Studies		
Emmett et al. 2006 n= 371, aged 2–89 yrs, median 50 yrs (317 from stratified random population sample) Linear regression (continuous PFOA) and t-test, PFOA, abnormal versus normal enzyme levels	Median 0.354 µg/mL (IQR 0.184 – 0.571 µg/mL); nonfasting blood sample	Linear regression, Beta (p-value) n (%) abnormal, (t-test p-value) ALP: -0.00416 (p = 0.65) 6 (2%) (p = 0.63) AST: -0.0007586 (p = 0.76) 9 (2%) (p = 0.03) ALT: -0.00183 (p = 0.65) 28 (8%) (p = 0.30) GGT: 0.00057711 (p = 0.89) 11 (3%) (p = 0.50)
Gallo et al. 2012 West Virginia, United States; C8 Health Project, 46,452 of 56,554 (82.1%) adults Adjusting for age, gender, physical activity, BMI, average household income, educational level, fasting status, month of blood sample collection, race, insulin resistance, alcohol consumption, and cigarette smoking	Median 0.028 µg/mL (IQR 0.135 – 0.71 µg/mL) nonfasting blood sample; LOD 0.0005 µg/mL, n = 32 below LOD	Linear regression, Logistic regression of abnormal values β per 1 unit increase PFOA (95% CI) OR (95% CI) Ln ALT: 0.022 (0.018 – 0.025) ALT: 1.10 (1.07, 1.13) Ln GGT: 0.015 (0.01 – 0.019) GGT: 1.01 (0.99, 1.04) n Direct (conjugated) bilirubin: 0.001 (-0.002 – 0.004) Direct bilirubin 0.97 (0.90, 1.05) Analysis of Ln ALT or Ln GGT by decile showed increase from 0.005 to 0.030 µg/mL, then leveling; p value for trend < 0.001; Direct bilirubin showed a U-shaped relation increasing to 0.030 µg/mL, then declining.
Cross-sectional: General Population Studies		
Lin et al. 2010 United States, NHANES (1999-2000; 2003-2004) 1,076 men, 1,140 women of 10,224 enrolled, excluding < 6-hr fast n = 1,802), and missing covariate or no serum PFOA or liver function of metabolic syndrome data Adjusting for age, gender, race/ethnicity, smoking, alcohol consumption, education level, BMI, metabolic syndrome, and iron saturation status	Geometric mean 0.00505 µg/mL 0.00406 µg/mL; 0.4% of samples below LOD (LOD 0.0002 and 0.0001 µg/mL in 1999- 2000 and 2003-2004)	β per unit (ng/ml) increase in log serum PFOA (95% CI) ALT: (U/l) 1.86 (1.24, 2.48) Log GGT: (U/l) 0.08 (0.05, 0.11) β per unit (ng/ml) increase in log serum PFOA (95% CI); Same model as above, also controlling for other PFASs ALT: (U/l) 2.19 (1.4, 2.98) Log GGT: (U/l) 0.15 (0.11, 0.19)

Occupational exposure studies. Olsen et al. (2000) analyzed alkaline phosphatase (ALP), GGT, aspartate aminotransferase (AST), ALT, and total- and direct bilirubin data from voluntary medical surveillance examinations of PFOA production workers at a 3M plant in 1993, 1995, and 1997. No association was observed between serum PFOA concentration and the parameters explored in cross-sectional analyses in the workers in 1993 or 1995; although in 1997 increases in AST per unit increase in serum PFOA concentration were observed. When measurements for all years were combined in longitudinal analyses (Olsen et al. 2003), the authors reported that no associations were observed with serum PFOA levels. Other than the analyses of AST, however, quantitative results were not provided.

A subsequent analysis involving these fluorochemical workers and an additional plant (Cottage Grove, Minnesota) that used medical surveillance data collected in 2000 examined the association between serum PFOA concentration and liver enzymes (Olsen and Zobel 2007). Serum samples were analyzed for ALP, GGT, AST, ALT, and bilirubin concentrations. Ln serum PFOA was marginally associated with ln ALT and ln GGT in regression models adjusting for ln age, ln BMI, and ln alcohol consumption, although the association was reduced when ln triglycerides replaced ln BMI in the model. An inverse association between total bilirubin and serum PFOA concentration ($p < 0.05$) was observed at all sites combined.

Sakr et al. (2007a) examined the relationship between serum PFOA and several clinical chemistry parameters in workers at the Washington Works plant in West Virginia. A complete blood count, metabolic panel (glucose, blood urea nitrogen [BUN], creatinine, iron, uric acid, electrolytes, creatinine kinase, lactic dehydrogenase [LDH], ALP, protein, albumin, C-reactive protein), liver enzyme panel (AST, ALT, GGT, bilirubin), and serum PFOA concentration were determined from the blood samples. Serum PFOA was associated ($p < 0.05$) with increasing GGT in all of the participating workers. It was stated that an association was observed between serum PFOA concentration and iron, LDH, calcium, and potassium, but quantitative results were not included and the direction of association was not specified.

Costa et al. (2009) also examined associations between serum PFOA concentration and liver enzymes in workers at a fluorochemical production plant in Italy. Serum PFOA concentration was associated with increasing ALT, GGT, and ALP levels ($p < 0.05$), and inversely associated with total bilirubin ($p < 0.01$) in 56 workers with PFOA and liver enzymes measured concurrently over the last 7 years. This subset of 56 workers included currently, formerly, and never exposed.

Sakr et al. (2007b) also conducted a longitudinal study of liver enzymes among workers at the Washington Works plant with two or more PFOA measurements as described previously. Hepatic clinical chemistry (GGT, AST, ALT, ALP, total bilirubin), height, and weight data were analyzed. Serum PFOA concentration was associated in the model with increasing AST levels ($p = 0.009$) and inversely associated with total bilirubin ($p = 0.006$) after adjustment for age, BMI, gender, and decade of hire. No association was observed between serum PFOA concentration and GGT, ALT, and ALP. The regression models did not adjust for alcohol consumption, a potential limitation.

High-exposure community studies. A small study ($n = 371$) of residents of the Little Hocking water district in Ohio found inconsistent results in different analyses of liver enzymes: An association with AST but not with ALP or ALT was seen when comparing serum PFOA levels between groups with abnormal compared to normal enzyme levels, but no association with any

enzyme was seen in regression analyses with PFOA as a continuous variable (Emmett et al. 2006). A subsequent study, which included a wider set of communities in the contaminated area, investigated the correlation between serum PFOA levels and liver enzymes in a total of 47,092 samples collected from members enrolled in the C8 Health Project (Gallo et al. 2012). The association of ALT, GGT, and direct bilirubin with PFOA was assessed using linear regression models adjusted for various confounders. The median PFOA level was 0.028 µg/mL. The ln-transformed values of ALT were significantly associated with ln-PFOA (and PFOS). There was a steady increase in fitted levels of ALT per decile of PFOA, leveling off after approximately 0.030 µg PFOA/mL. Fitted values of GGT by deciles of PFOA showed a slight positive trend when adjusted for insulin resistance and BMI, but this was not confirmed in the logistic model analysis of elevated enzyme levels. Direct bilirubin levels appeared to increase at lower concentrations and then decline in a U-shaped pattern at 0.030 µg PFOA/mL.

General population studies. Lin et al. (2010) investigated the association between serum PFOA (plus three other PFASs) and liver enzymes in the adult population of the United States by analyzing data from the 1999–2000 and 2003–2004 NHANES. The study population included 2,216 adults (1076 males, 1140 females) older than 20 years who were not pregnant or nursing; had fasted more than 6 hours at the time of examination; were negative for hepatitis B or C virus; had body weight, height, educational attainment, and smoking status data available; and had serum tests for PFAS, liver function, or the five physiological measures associated with metabolic syndrome. Regression models were used to analyze the data and adjust for confounders. Mean PFOA levels were 0.00505 µg/mL and 0.00406 µg/mL for males and females, respectively. Serum PFOA concentration was divided into quartiles (Q1 = ≤ 0.0029; Q2 = ≤ 0.0042; Q3 = ≤ 0.00595; Q4 = > 0.00595 µg/ml). In the univariate regression models, liver enzymes, serum ALT, and log-GGT increased across quartiles of PFOA ($p \leq 0.012$), but total bilirubin showed no trend. The linear regression models were adjusted for (1) age, gender, and race/ethnicity; (2) age, gender, race/ethnicity, and lifestyle (smoking status, drinking status, education level), and (3) additional data for BMI, metabolic syndrome biomarkers, iron saturation status, and insulin resistance. An association was found between serum log-PFOA concentration and increasing serum ALT and log-GGT. One unit increase in serum log-PFOA was associated with an increase of 1.86 units in serum ALT measurements and a 0.08-unit increase in log-GGT measurements. Effect modification was seen: For example, stronger associations between serum PFOA concentration and serum ALT (or GGT) were found among non-Hispanic Caucasians. PFOS also was positively associated with ALT in the fully adjusted model.

The results of the occupational studies provide evidence of an association with increases in serum AST, ALT, and GGT, with the most consistent results seen for ALT. The associations were not large and they might depend on the covariates in the models such as BMI, use of lipid-lowering medications, and triglycerides (Costa et al. 2009; Olsen et al. 2000, 2003; Olsen and Zobel 2007; Sakr et al. 2007a, 2007b). Two population-based studies of highly exposed residents in contaminated regions near a fluorochemical industry in West Virginia have evaluated associations with liver enzymes, and the larger of the two studies reported associations of increasing serum ln ALT and ln GGT levels with increasing serum PFOA concentrations (Emmett et al. 2006; Gallo et al. 2012). A cross-sectional analysis of data from NHANES, representative of the U.S. national population, also found associations with ln PFOA concentration with increasing serum ALT and ln GGT levels. Serum bilirubin was inversely associated with serum PFOA in the occupational studies. A U-shaped exposure-response pattern for serum bilirubin was observed among the participants in the C8 Health Project, which might explain the inverse associations reported for occupational cohorts. Overall, an association of

serum PFOA concentration with elevations in serum levels of ALT and GGT has been consistently observed in occupational and highly exposed residential communities, and the U.S. general population. The associations are not large in magnitude, but indicate the potential of PFOA to affect liver function.

Liver Diseases

High-exposure community studies. Few studies of the relationship between PFOA and liver disease are available, but the C8 Health Project did not observe associations with hepatitis, fatty liver disease, or other types of liver disease in their initial studies. The most recent update of disease incidence in the workers identified 35 cases of nonhepatitis liver disease (with medical validation) (Steenland et al. 2015); no association was seen with cumulative exposure when analyzed without a lag (HRs by quartile 1.0, 0.58, 1.43, 1.20; trend $p = 0.86$ for log cumulative exposure), but there was a possible trend in the analysis using a 10-year lag (HRs by quartile 1.0, 1.46, 2.13, and 2.02; trend $p = 0.40$).

3.1.1.4 Biomarkers of Kidney Function and Kidney Disease

Kidney Function

PFOA has the potential to affect the kidney’s function of tubular resorption because of it uses tubular transporters for excretion and resorption (see section 2.4). Since PFOA is removed from the blood by the kidney, cross-sectional analyses using serum PFOA as the exposure measure are problematic if individuals with compromised kidney function are included: PFOA concentrations could be increased in those individuals and an apparent association with GFR would be observed, even if one did not exist. Studies examining measures of kidney function are described in this section and summarized in Table 3-5.

Table 3-5. Summary of Epidemiology Studies of PFOA and Measures of Kidney Function

Reference and Study Details	PFOA Level	Results
Sakr et al. 2007a Washington Works plant Cross-sectional; all active, nonpregnant employees enrolled over 12 days in 2004 1,025 of 1,863 eligible (55%)	0.428 µg/ml LOQ 0.0005 µg/ml range 0.005–9.55 µg/mL	Reported association with uric acid but quantified results were not provided
Costa et al. 2009 Italy Cross-sectional 56 male workers (currently and formerly exposed and unexposed) with concurrent serum PFOA and clinical parameters measured in last 7 yrs	Currently exposed: mean 12.9, geometric mean 4.02, range 0.2–47 µg/mL Formerly exposed: mean 6.81 geometric mean 3.76, range 0.53–18 µg/mL	β change per µg PFOA/mL (95% CI) Uric acid 0.026 (0.001, 0.053) GEE models adjusting for age, years of exposure, year of PFOA sampling, BMI, smoking, and alcohol consumption

Reference and Study Details	PFOA Level	Results
<p>Steenland et al. 2010 C8 Health Project, West Virginia Cross-section; adult subjects (n = 53,458; 20–≥80 years of age) participating in the C8 Health Project from 2005–2006 Subjects had consumed water for at least 1 year prior to 2004</p>	<p>0.0864 µg/mL, measured in 2005–2006</p>	<p>Increased predicted uric acid of 0.2–0.3 µg/dL with increasing deciles of PFOA or PFOS</p>
<p>Shankar et al. 2011 United States, NHANES Uric acid analysis: 1999–2000, 2003–2004 and 2005–2006 cycles 3,883 out of 3,974 participants ≥ 20 years of age with serum PFOA measurements; excluded subjects with missing data (n = 91); 48.3% male, mean age 46.4 years</p> <p>eGFR analysis: 1999–2000, 2003–2004, 2005–2006, and 2007–2008 cycles 4,587 out of 5,717 (80%) eligible 20 years or older with PFOA measures; excluded self-reported CVD (n = 572), missing data on serum creatinine or covariates (n = 558)</p>	<p>0.0059 µg/mL; LOD 0.1 ng/mL Quartiles, µg/mL, n 1 < 0.0028 µg/mL, 1,176 2 0.0028–0.0041 µg/mL, 1,141 3 0.0042–0.0059 µg/mL, 1,141 4 > 0.0059 µg/mL, 1,129</p>	<p>Mean change in uric acid, mg/dL (95% CI) by quartile 1 referent 2 0.14 (0.04–0.25) 3 0.37 (0.25–0.49) 4 0.44 (0.32–0.56), p trend 0.0001 Mean change in uric acid, mg/dL (95% CI) by ln PFOA: 0.22 (0.15–0.30) Multivariate regression adjusting for age, gender, race/ethnicity, education, smoking, alcohol consumption, BMI, hypertension, diabetes, and serum total cholesterol Hyperuricemia risk by quartile, OR (95% CI) 1 referent 2 1.14 (0.78–1.67) 3 1.90 (1.35–2.69) 4 1.97 (1.44–2.70), p trend 0.0001 Hyperuricemia risk per unit increase in ln PFOA, OR (95% CI): 1.43 (1.16–1.76) Logistic regression adjusting for age, gender, race/ethnicity, education, smoking, alcohol consumption, BMI, hypertension, diabetes, and serum total cholesterol Chronic kidney disease defined as eGFR < 60 mL/min/1.73 m² Quartile, OR (95% CI) 1 referent 2 0.83 (0.55–1.24) 3 1.24 (0.75–2.05) 4 1.73 (1.04–2.88) Logistic regression adjusting for age, gender, race/ethnicity, education, smoking, alcohol consumption, BMI, systolic blood pressure, diastolic blood pressure, diabetes, serum TC, and glycohemoglobin Adjustment for PFOS did not alter association with PFOA Multivariate regression of association PFOA with eGFR among subjects with and without chronic kidney disease β (SE) with -1.6 (0.8) and without -2.8 (0.6) chronic kidney disease</p>

Reference and Study Details	PFOA Level	Results
Watkins et al. 2013 West Virginia Cross-sectional population-based survey, residents near the Washington Works plant (C8 Health Project) 9,660 (children < 18 yrs) out of 9,783 eligible with complete data for serum creatinine, height, and serum PFOA	Median measured PFOA 0.0283 µg/mL; range 0.0007–2.071; yearly serum PFOA estimated for each individual from model used to predict serum PFOA at time of enrollment, historical serum PFOA during the first 10 years of life, 3 years before enrollment or at birth	β (95% CI) change in unit eGFR (mL/min/1.73 m ²) per ln serum PFOA, -0.75 (-1.41–0.010) Linear regression adjusting for age, gender, race, smoking, and household income; additional adjustment for regular exercise, BMI z-score, and TC did not alter association No associations of predicted serum PFOA (modeled) with eGFR

Uric Acid (risk factor for hypertension)

Occupational exposure studies. Costa et al. (2009) examined associations between serum PFOA concentration and uric acid levels in serum in workers at a fluorochemical production plant in Italy. Serum PFOA concentration was associated with uric acid levels ($p < 0.05$) in 56 workers assessed concurrently over the previous 7 years. This subset of 56 workers included currently, formerly, and never exposed with relatively high serum PFOA concentrations.

High-exposure community studies. Steenland et al. (2010) examined the association of serum PFOA concentrations with uric acid levels in adult subjects ($n = 53,458$; $20 \geq 80$ years) participating in the C8 Health Project from 2005–2006. The reference range for uric acid is 2.0–8.5 mg/dL. Serum samples were separated into deciles or quintiles for analysis. The data were analyzed by linear and logistic regression with uric acid as the outcome and PFOA as the exposure variable. Covariates of the model included age, gender, BMI, education, smoking, alcohol consumption, and serum creatinine. The mean serum PFOA concentration was 0.0864 µg/mL. The mean uric acid level was 5.58 mg/dL with an IQR of 4.5–6.6 mg/dL. The increase in uric acid from lowest to highest serum PFOA concentration decile was 0.2–0.3 mg/dL. The OR for high serum uric acid levels increased from the lowest to the highest quintile of PFOA serum concentrations: 1.00, 1.33 (95% CI: 1.24–1.43), 1.35 (95% CI: 1.26–1.45), 1.47 (95% CI: 1.37–1.58), and 1.47 (95% CI: 1.37–1.58). The study showed that higher serum PFOA concentrations were associated with higher incidence of high serum uric acid levels. The serum of C8 study participants included several PFASs; PFOA appeared to have a greater influence on uric acid trends than PFOS in the models employed by Steenland et al. (2010).

The C8 Science Panel (2012) combined the data from the C8 general population cohort with data from worker cohorts and concluded that there is no probable link between PFOA and stroke, hypertension, and coronary artery disease. The general population cohorts were not evaluated separately in these analyses.

General population studies. Shankar et al. (2011) investigated the association between serum PFOA (and PFOS) and uric acid concentration in the adult population of the United States by analyzing data from the 1999–2000, 2003–2004, and 2005–2006 NHANES evaluations. The study population included 3,883 adults (48.3% male) older than 20 years with data available for serum PFOA, plasma uric acid, and important covariates. Regression models were used to analyze associations with serum PFOA as a continuous variable and in quartiles. Logistic regression models analyzed risk for hyperuricemia defined as plasma uric acid > 6.8 mg/dL in males and > 6.0 mg/dL in females. Ln PFOA concentration was associated with increasing uric

acid concentration in multivariate models adjusting for age, gender, race/ethnicity, education, smoking, alcohol consumption, BMI, hypertension, diabetes, and serum TC. Mean uric acid concentration increased by 0.22 (95% CI 0.15–0.30) mg/dL per unit change in ln PFOA. A concentration-response relationship was indicated across all quartiles. In addition, an elevated hyperuricemia risk was observed with increasing serum PFOA concentration (OR 1.43, 95% CI 1.16–1.76).

Glomerular Filtration Rate

High-exposure community studies. Watkins et al. (2013) evaluated the cross-sectional association between PFOA exposure and kidney function among children aged 1<18 years (mean 12.4 ± 3.8 years) enrolled in the C8 Health Project. A total of 9,660 participants had data available on serum PFOA (median 0.0283 $\mu\text{g/mL}$), as well as serum creatinine and height, which were used to calculate an estimated glomerular filtration rate (eGFR). Linear regression was used to evaluate the association between quartiles of measured serum PFOA concentration and eGFR. A shift from the lowest to the highest quartile of measured, natural log-transformed concentrations of PFOA in serum [IQR $\ln(\text{PFOA}) = 1.63$] was associated with a decrease in eGFR of 0.75 mL/min/1.73 m^2 (95% CI: -1.41, -0.1; $p = 0.02$) adjusting for age, gender, race, smoking status, and household income. With increasing quartile of serum PFOA concentrations, eGFR decreased monotonically, although the change was slight and did not attain statistical significance (p for trend across quartiles = 0.30). PFOS also was associated with a decrease in eGFR and showed a dose-related trend. Modeled predicted serum PFOA and PFOS concentrations were not associated with eGFR.

General population studies. Shankar et al. (2011) also used data from the NHANES to determine whether there was a relationship between serum PFOA levels and chronic kidney disease defined as eGFR (determined from serum creatinine) of less than 60 mL/min/1.73 m^2 . Serum PFOA levels were categorized into quartiles: Q1 = <0.0028 $\mu\text{g/mL}$; Q2 = 0.0028–0.0041 $\mu\text{g/mL}$; Q3 = 0.0042–0.0059 $\mu\text{g/mL}$; Q4 = >0.0059 $\mu\text{g/mL}$. The adjusted OR for chronic kidney disease for individuals in Q4 was 1.73 (95% CI: 1.04, 2.88; p for trend = 0.015) compared with individuals in Q1. The logistic regression model was adjusted for age, gender, race/ethnicity, education, smoking, alcohol consumption, BMI, systolic blood pressure, diastolic blood pressure, diabetes, serum TC, and glycohemoglobin. Although a similar increase in OR was seen for PFOS, additional adjustment for serum PFOS did not alter the association with PFOA. In addition, the inverse association of eGFR with serum PFOA was observed over all quartiles of PFOA, as well as among individuals both with and without chronic kidney disease. Although the possibility of reverse causality could not be excluded, the association between serum PFOA and eGFR among participants without chronic kidney disease suggests a PFOA-related effect on kidney function.

Overall, studies of occupational cohorts (Costa et al. 2009), a highly exposed community (Steenland et al. 2010; Watkins et al. 2013), and the U.S. general population (Shankar et al. 2011) that evaluated uric acid levels or eGFR as a measure of kidney function found associations with decreased function, although reverse causality as an explanation cannot be ruled out. Since the URAT transporter functions in the renal resorption of PFOA, the increase in serum uric acid could be a reflection of systemic transport pharmacodynamics rather than formation biochemistry.

Kidney Disease

The occupational mortality studies have produced generally negative results with respect to the association between PFOA and mortality due to chronic kidney disease (Steenland et al. 2015; Steenland and Woskie 2012; Raleigh et al. 2014). The most recent update of incidence of chronic kidney disease in the workers in the C8 West Virginia community identified 43 cases (with medical validation) (Steenland et al. 2015); no association was seen with cumulative exposure when analyzed without a lag (HRs by quartile 1.0, 0.50, 0.69, 0.67; trend $p = 0.92$ for log cumulative exposure), or using a 10-year lag (HRs by quartile 1.0, 1.32, 0.50, and 0.67; trend $p = 0.99$).

In 2012, the C8 Science Panel concluded that there is no probable link between PFOA and chronic kidney disease. Their conclusion was based on findings in combined general population and worker cohorts, data on children enrolled in the C8 Health Project, and published data from NHANES.

3.1.1.5 Immunotoxicity

Immune suppression

Immune function—specifically immune system suppression—can affect numerous health outcomes, including risk of common infectious diseases (e.g., colds, flu, otitis media) and some types of cancer. The World Health Organization (WHO) guidelines for immunotoxicity risk assessment recommend measures of vaccine response as a measure of immune effects, with potentially important public health implications (WHO 2012).

Associations between prenatal PFOA exposure and risk of infectious diseases (as a marker of immune suppression) were not seen in two studies, although there was some indication of effect modification by gender (i.e., associations seen in females but not in males). Fei et al. (2010a) examined hospitalizations for infectious diseases in early childhood in a Danish birth cohort. Mean maternal PFOA concentration was 0.0056 $\mu\text{g/mL}$. A slightly higher risk for hospitalizations was observed in females with higher maternal PFOA concentrations (incidence rate ratio [IRR] = 1.00, 1.20, 1.63, 1.74 for Q1, Q2, Q3, and Q4, respectively), and the risk for males was below 1.0 for each quartile. Overall, there was no association between hospitalizations due to infectious diseases and maternal PFOA exposure; similar results were found with PFOS.

Okada et al. (2012) examined history of otitis media (and of allergic conditions) in children up to the age of 18 months. Mean maternal PFOA concentration was 0.0014 $\mu\text{g/mL}$. Cord blood immunoglobulin E (IgE) level decreased significantly with high maternal PFOA concentration among female infants, but not male infants. No significant associations were observed between maternal PFOA levels (and PFOS) with the incidence of otitis media (or specific types of allergies or wheeze). Two other studies, described below, examined reported history of colds and gastroenteritis in children up to age 3 years (Granum et al. 2013) or colds and flu in adults (Looker et al. 2014). Granum et al. (2013) observed associations between prenatal PFOA exposure and frequency of colds or gastroenteritis episodes, but not with a variable based on “ever had” this condition in the past year. Looker et al. (2014) did not observe associations between serum PFOA and “ever had” or frequency of colds or flu in the past year.

In 2012, the C8 Science Panel (2012) concluded that there is no probable link between PFOA and common infections, including influenza, in children or adults. The panel based their

conclusions on a subset of adult members of the cohort, a subset of mother-child pairs, and published data from other researchers.

Three studies have examined response to one or more vaccine (e.g., measured by antibody titer) in relation to higher exposure to PFOA in children (Grandjean et al. 2012; Granum et al. 2013) or adults (Looker et al. 2014); the latter study was conducted in the high-exposure C8 community population (Table 3-6).

Table 3-6. Summary of Epidemiology Studies of PFOA and Immune Suppression (Vaccine Response)

Reference and Study Details	PFOA Level	Results		
High-Exposure Community: Adults				
Looker et al. 2014 C8 Health Project, West Virginia 2005-2006 enrollment and baseline blood sample and questionnaires; 2010 follow-up n = 411 with prevaccination blood sample – flu vaccination – 21-day post vaccination blood sample Linear regression: antibody titer rise Logistic regression: seroconversion and seroprotection	Median 0.032 µg/mL	(Percentage positive) OR (95% CI), by influenza strain:		
	Q1: 0.0025-0.0137	Seroconversion (fourfold increase in antibody titer)	Seroprotection (antibody titer 1:40 following vaccine)	
	Q2: 0.0138 – 0.0315	Influenza B	(62%)	(66%)
	Q3: 0.0316 – 0.0903	PFOA continuous	0.80 (0.53, 1.21)	1.04 (0.68, 1.60)
	Q4: 0.0904 – 2.14	Q1	1.0 (referent)	1.0 (referent)
		Q2	1.43 (0.76, 2.70)	0.76 (0.40, 1.45)
		Q3	1.39 (0.73, 2.66)	1.13 (0.57, 2.23)
		Q4	0.71 (0.38, 1.36)	0.77 (0.39, 1.50)
		A/H1N1	(84%)	(96%)
		PFOA continuous	(84%)	(96%)
		Q1	1.0 (referent)	1.0 (referent)
		Q2	0.74 (0.34, 2.70)	0.74 (0.17, 3.28)
		Q3	1.11 (0.73, 2.66)	1.59 (0.33, 7.70)
		Q4	2.23 (0.38, 1.36)	6.47 (0.91, 45.9)
	A/H3N2	(65%)	(84%)	
	PFOA continuous	0.76 (0.51, 1.15)	0.66 (0.39, 1.12)	
	Q1	1.0 (referent)	1.0 (referent)	
	Q2	0.90 (0.48, 1.68)	0.34 (0.14, 0.83)	
	Q3	1.13 (0.59, 2.17)	0.28 (0.11, 0.70)	
	Q4	0.62 (0.33, 1.66)	0.36 (0.15, 0.99)	
General Population: Children				
Grandjean et al. 2012 Faroe Islands Birth cohort, follow-up to age 7 yrs n = 587 Age 5 prebooster (e.g., tetanus, diphtheria) and 4 weeks after booster and age 7 PFOA in 3 rd trimester blood sample and in child (age 5) Linear regression, adjusted for gender, age, birth weight, maternal smoking, breast-feeding, and PCBs (and time since booster for post-booster analysis)	Geometric mean Maternal sample 0.0032 µg/mL	Log PFOA and Log antibody Beta (95% CI) [% change in antibody titer per twofold increase in PFOA]		
	Child's sample 0.004 µg/mL	Maternal PFOA	Tetanus	Diphtheria
		Prebooster	-10.5 (-28.2, 11.7)	-16.2 (-34.2, 6.7)
		Postbooster	14.5 (-10.4, 46.4)	-6.2 (-22.4, 13.3)
		Year 7 (adjusted for age 5)	12.3 (-8.6, 38.1)	-16.8 (-32.9, 3.3)
		Child's PFOA	Tetanus	Diphtheria
		Prebooster	-13.3 (-31.6, 9.9)	-6.8 (-28.3, 21.0)
		Postbooster	-9.7 (-30.7, 17.7)	-6.1 (-23.6, 15.5)
		Year 7 (adjusted for age 5)	-28.2 (-42.7, -10.1)	-23.4 (-39.3, -3.4)
			Similar results seen with PFOS	
Granum et al. 2013 Norway Birth cohort, Norwegian Mother and Child Cohort Study n = 56 with maternal blood at delivery and child blood samples at 3 yrs Linear regression, considered potential confounders	Mean 0.001 µg/mL	Beta (95% CI) (p-value), PFOA and antibody titer		
		Rubella	-0.40 (-0.64, -0.17)	(p = 0.001)
		Measles	-0.13 (-0.35, 0.09)	(p = 0.24)
		Tetanus	0.01 (-0.009, 0.10)	(p = 0.92)
		Hib	-0.05 (-3.85, 3.74)	(p = 0.98)
		Similar results for other PFAS		

A cohort of 411 adult members of the C8 Health Project was evaluated in 2010 for an association between serum PFOA levels and antibody response following vaccination with an inactivated trivalent influenza vaccine (Looker et al. 2014). A prevaccination serum sample was collected at the time of vaccination and the postvaccination serum sample was collected 21 ± 3 days later. The geometric mean serum PFOA level was $0.0337 \mu\text{g/mL}$ (95% CI 0.0298, 0.0382) and participants were divided into quintiles for analyses. PFOA was negatively associated with geometric mean A/H3N2 antibody titer rise, but no association was found with antibody titers for A/H1N1 and influenza type B. No association was found between antibody titers and PFOS levels.

Antibody responses to diphtheria and tetanus toxoids following childhood vaccinations were assessed in context of exposure to five perfluorinated compounds (Grandjean et al. 2012). The prospective study included a birth cohort of 587 singleton births during 1999–2001 from the National Hospital in the Faroe Islands. Serum antibody concentrations were measured in children at age 5 years prebooster, approximately 4 weeks after the booster, and at age 7 years. Prenatal exposures to perfluorinated compounds were assessed by analysis of serum collected from the mother during week 32 of pregnancy (PFOA geometric mean $0.0032 \mu\text{g/mL}$; IQR 0.00256–0.00401); postnatal exposure was assessed from serum collected from the child at 5 years of age (PFOA geometric mean $0.00406 \mu\text{g/mL}$; IQR 0.00333–0.00496). Multiple regression analyses with covariate adjustments were used to estimate the percent difference in specific antibody concentrations per twofold increase in PFOA concentration in both maternal and 5-year serum. Maternal PFOA serum concentration was negatively associated with antidiphtheria antibody concentration (-16.2%) at age 5 before booster. The biggest effect was found in comparison of antibody concentrations at age 7 with serum PFOA concentrations at age 5 where a twofold increase in PFOA was associated with differences of -36% (95% CI, -52%–14%) and -25% (95% CI, -43%–2%) for tetanus and diphtheria, respectively. Additionally at age 7, a small percentage of children had antibody concentrations below the clinically protective level of 0.1 international unit (IU) /mL. The ORs of antibody concentrations falling below this level were 4.20 (95% CI, 1.54–11.44) for tetanus and 3.27 (95% CI, 1.43–7.51) for diphtheria when age 7 antibody levels were correlated with age 5 PFOA serum concentrations. Maternal and child PFOS levels also were negatively associated with antibody titers in children.

The effects of prenatal exposure to perfluorinated compounds on vaccination responses and clinical health outcomes in early childhood were investigated in a subcohort of the Norwegian Mother and Child Cohort Study (Granum et al. 2013). A total of 56 mother-child pairs, for whom both maternal blood samples at delivery and blood samples from the children at 3 years of age, were evaluated. Antibody titers specific to measles, rubella, tetanus, and influenza were measured as these vaccines are part of the Norwegian Childhood Vaccination Program. Serum IgE levels also were measured. Clinical health outcomes, including common colds and gastroenteritis, at ages 1, 2, and 3 years were assessed by means of a questionnaire sent to participants. Mean maternal plasma PFOA concentration was $0.0011 \mu\text{g/mL}$ at delivery; the PFOS level was $0.0056 \mu\text{g/mL}$ and PFNA and PFHxS were below the LOQ. PFOA levels in the children were not measured. No associations were found with PFOA or any perfluorinated compound and antibody levels to the vaccines with one exception. A slight, but significant, inverse relationship between maternal PFOS level and anti-rubella antibodies in children at 3 years was found ($\beta = -0.8$ [95% CI -0.14, -0.02]). Maternal PFOA levels were not associated with adverse childhood health outcomes.

In summary, three studies have reported decreases in response to one or more vaccines (e.g., measured by antibody titer) in relation to higher exposure to PFOA in children (Grandjean

et al. 2012; Granum et al. 2013) and adults (Looker et al. 2014). In the two studies examining exposures in the background range (i.e., general population exposures, < 0.010 µg/ml), the associations with PFOA also were seen with other correlated PFASs. This limitation was not present in the study in adults in the high-exposure C8 community population. Serum PFOA levels in this study population were approximately 0.014–0.090 µg/mL.

Asthma

The association between serum levels of perfluorinated compounds and childhood asthma was investigated by Dong et al. (2013). The cross-sectional study included a total of 231 children aged 10–15 years with physician-diagnosed asthma and 225 age-matched nonasthmatic controls. Between 2009 and 2010, asthmatic children were recruited from two hospitals in Northern Taiwan, while the controls were part of a cohort population in seven public schools in Northern Taiwan. Serum was collected for measurement of 10 perfluorinated compounds, absolute eosinophil counts, total IgE, and eosinophilic cationic protein. A questionnaire was administered to asthmatic children to assess asthma control and to calculate an asthma severity score (e.g., frequency of attacks, use of medicine, and hospitalization) during the previous 4 weeks. Associations of perfluorinated compound quartiles with concentrations of immunological markers and asthma outcomes were estimated using multivariable regression models. Nine of 10 perfluorinated compounds were detectable in ≥84.4% of all children with levels generally higher in asthmatic children than in nonasthmatics. Serum concentrations of PFOA in asthmatic and nonasthmatic children were 0.0015 ± 0.0013 µg/mL and 0.0010 ± 0.0011 µg/mL, respectively; four other compounds were measured at higher concentrations with the highest levels for PFOS and perfluorotetradecanoic acid. The adjusted ORs for asthma association with the highest versus lowest quartile levels were significantly elevated for seven of the compounds. For PFOA, the OR was 4.05 (95% CI: 2.21, 7.42). In asthmatic children, absolute eosinophil counts, total IgE, and eosinophilic cationic protein concentration were positively associated with PFOA levels with a significant monotonic trend with increasing serum concentration. None of these biomarkers were significantly associated with PFOA levels in nonasthmatic children. Serum PFOA levels were not significantly associated with asthma severity scores among the children with asthma, although four other compounds did show an association.

Humblet et al. (2014) evaluated a cohort from NHANES to investigate children's PFAS serum levels, including PFOA, and their association with asthma-related outcomes. Sera were analyzed for 12 PFASs with focus on PFOA, PFOS, PFHxS, and PFNA. A total of 1,877 children aged 12–19 years with at least one serum sample available were included. Asthma and related outcomes were self-reported. Median serum PFOA levels were 0.0043 µg/mL for those ever having asthma and 0.0040 µg/mL for children without asthma. In the multivariable adjusted model, a doubling of PFOA level was associated with an increased odds of ever having asthma (OR=1.18, 95% CI 1.01, 1.39). PFOS was inversely associated with asthma and no associations were found between the other PFAS and outcome.

On the basis of epidemiological and other data available, the C8 Science Panel (2012) found no probable link between PFOA and asthma in children and adults and chronic obstructive pulmonary disease (COPD) in adults.

Autoimmune conditions

The most recent report on the worker cohort initially described by Leonard et al. (2008) included 6,026 workers evaluated for disease incidence, not just mortality (Steenland et al.

2015). Lifetime serum cumulative dose was estimated by combining occupational and nonoccupational exposures. Median measured serum level was 0.113 µg/mL based on samples collected in 2005. Statistically significant positive trends were found between log of cumulative exposure and ulcerative colitis and rheumatoid arthritis. Rate ratios for the highest quartile compared to the lowest quartile were 2.74 (95% CI 0.78, 9.65) for ulcerative colitis and 4.45 (95% CI 0.99, 19.9) for rheumatoid arthritis.

The C8 Science Panel (2012) combined these data with findings from the C8 general population cohort and concluded that there is a probable link between PFOA and ulcerative colitis. Using historical estimates for serum PFOA, the C8 Science Panel found a significant positive, dose-response trend with a relative risk (RR) for the highest quartile compared to the lowest of 3.18 (95% CI 1.84, 5.51). The panel concluded that there was no probable link between PFOA and autoimmune diseases, including rheumatoid arthritis, lupus, type1 diabetes, Crohn's disease, or multiple sclerosis. The C8 Science Panel also concluded that there is no probable link between PFOA and osteoarthritis. These analyses by the panel included both worker and general population cohorts.

3.1.1.6 Thyroid Effects

Several epidemiology studies have evaluated thyroid function and/or thyroid disease and its association with serum PFOA concentrations. Thyroid disease is more common in females than in males. Among the PFOA studies, the three most highly powered studies with the largest number of participants are one from the general U.S. population (Melzer et al. 2010) and two from highly exposed individuals within the C8 population (Lopez-Espinosa et al. 2012; Winquist and Steenland 2014b). Two of these studies are of adults (Melzer et al. 2010; Winquist and Steenland 2014b) and one is of children/adolescents (Lopez-Espinosa et al. 2012). Hypothyroidism is characterized by elevated thyroid stimulating hormone (TSH) and low T4; elevated TSH in conjunction with normal T4 and triiodothyronine (T3) is defined as subclinical hypothyroidism. Hyperthyroidism is characterized by elevated T4 and low TSH; low levels of TSH in conjunction with normal T4 and T3 is defined as subclinical hyperthyroidism. Some studies focused on the prevalence of clinically defined disease (or the subclinical state), and others examined variations in TSH, T4, and T3 measurements among people who have not been diagnosed with a thyroid disease. Both hypothyroidism and hyperthyroidism can result from an autoimmune pathogenesis involving destruction of thyroid tissue. A summary of the studies on PFOA's association with thyroid disease or changes in thyroid hormones follows, and is depicted in Table 3-7 (studies in adults) and Table 3-8 (studies in special populations—children and pregnant females).

Occupational exposure studies. Serum PFOA levels were obtained from volunteer workers of the Cottage Grove, Minnesota, PFOA plant in 1993 (n = 111) and 1995 (n = 80) as part of the medical surveillance program and analyzed to determine a relationship between TSH and PFOA concentration (Olsen et al. 1998). Employees were placed into four exposure categories based on their serum PFOA levels: 0–1 µg/mL, 1– < 10 µg/mL, 10– < 30 µg/mL, and >30 µg/mL. Statistical methods used to compare PFOA levels and hormone values included multivariable regression analysis, ANOVA, and Pearson correlation coefficients. TSH was significantly (p = 0.002) elevated in 10–<30 µg/mL exposure category for 1995 only (mean serum TSH level was 2.9 ppm). However, mean TSH levels for the other exposure categories, including the ≥30 µg/mL category, were all the same (1.7 ppm). In 1993, TSH was elevated in this same exposure category, but was not statistically significant (p = 0.09) when compared to the other exposure categories.

Table 3-7. Summary of Epidemiology Studies of PFOA and Thyroid Effects in Adults

Reference and Study Details	PFOA Level	TSH	T3	T4
Occupational Exposure Studies				
Olsen and Zobel 2007 3M. Antwerp, Cottage Grove, Decatur combined; 50-65% participation rate n= 506 Mean age: 40 yrs Mean duration: not reported Linear regression adjusting for ln age, ln BMI, ln alcohol (Related references: Olsen et al. 1998, 2003)	Mean (range) 2.21 (0.01–92.03) µg/mL	Beta (±SE) (p-value), ln PFOA and ln TSH: 0.0360 (± 0.0207) (p = 0.08)	Beta (±SE) (p-value), ln PFOA and ln T3: 0.0105 (± 0.0053) (p = 0.05)	Beta (±SE) (p-value), ln PFOA and ln T4: -0.0057 (± 0.0054) (p = 0.29) Beta (±SE) (p-value), ln PFOA and ln FT4: -0.0117 (± 0.0043) (p = 0.01)
Steenland et al. 2015 n = 3,713 workers Data collected in 2005-2006 and 2008-2011 n = 82 cases in men, 77 cases in women	In 2005-2006: mean 0.325 µg/mL, median 0.113 µg/mL	HR (95% CI), for self-reported thyroid disease, with medical record validation (incidence based on year of diagnosis). Cumulative exposure quartile, no lag In men: In women: 1.0 (referent) 1.0 (referent) 1.64 (0.82, 3.29) 1.00 (0.54, 1.87) 1.13 (0.50, 2.54) 1.02 (0.48, 2.17) 2.16 (0.98, 4.77) 0.33 (0.08, 1.26) (<i>P</i> _{trend} = 0.98) (<i>P</i> _{trend} = 0.97)		
Adults: High-Exposure Community Studies				
Emmett et al. 2006 n = 371, aged 2–89 yrs, median 50 yrs (317 from stratified random population sample) t-test, PFOA in abnormal vs normal TSH levels	0.354 µg/mL	6% abnormal; p-value of t-test comparing PFOA in abnormal and normal = 0.59	Not measured	Not measured
Winquist and Steenland 2014b n = 32,254 (including 3,713 workers) Data collected in 2005-2006 and 2008-2011 n = 2,008 cases in primary analysis n = 454 cases in prospective analysis (diagnoses after 2005-2006) Stratified by gender; also conducted separate analyses for hyperthyroidism and hypothyroidism	In 2005-2006: mean 0.0866 µg/mL, median 0.0261 µg/mL	HR (95% CI), incident thyroid disease (with medical record validation), primary analysis: Cumulative exposure quintiles Year exposure quintiles: Full sample Men Women Full sample Men Women 1.0 (referent) 1.0 1.0 1.0 (referent) 1.0 1.0 1.21 1.12 1.24 1.23 1.13 1.26 1.17 0.83 1.27 1.24 1.11 1.28 1.27 1.01 1.36 1.10 1.06 1.11 1.2 1.05 1.37 1.28 1.04 1.38 (<i>P</i> _{trend} = 0.03) (<i>P</i> _{trend} = 0.85) (<i>P</i> _{trend} = 0.03) (<i>P</i> _{trend} = 0.04) (<i>P</i> _{trend} = 0.97) (<i>P</i> _{trend} = 0.008)		

Reference and Study Details	PFOA Level	TSH	T3	T4
		Diagnoses after 2005: Cumulative exposure quintiles Full sample Men Women Year exposure quintiles: 1.0 (referent) 1.0 1.0 Full sample Men Women 1.23 1.35 1.23 0.80 1.32 0.74 1.00 1.37 0.93 0.91 2.09 0.76 1.06 1.44 1.00 0.93 1.83 0.82 1.12 1.85 0.96 0.91 1.76 0.80 ($P_{trend} = 0.73$) ($P_{trend} = 0.09$) ($P_{trend} = 0.55$) ($P_{trend} = 0.86$) ($P_{trend} = 0.54$) ($P_{trend} = 0.53$)		
Adults: General Population Studies				
Bloom et al. 2010 United States (New York; New York State Anglers Cohort Study) n = 31 (4 women) Mean age: 39 yrs (31–45 years) Linear regression, adjusted PFOA-PFOS correlation r = 0.35	Geometric mean 0.0013 µg/mL	Log-PFOA and log-TSH: Beta = -0.06 (-0.78, 0.67) (p = 0.87)	Not measured	Log-PFOA and log-T4: Beta = -0.01 (-0.16, 0.14) (p = 0.89)
Shrestha et al. 2015 United States (Upper Hudson River Valley) n = 87 (with serum for analyses); excluded if taking thyroid medicine Aged: 55–74 yrs PFOA-PFOS correlation r = 0.52 Linear regression, adjusted	Geometric mean (IQR) 0.0092 (0.0071–0.0131) µg/mL	Log-PFOA and log-TSH: Beta = 0.102 (-0.047, 0.25) (p = 0.18)	Log-PFOA and log-T3: Beta 3.03 (-1.73, 7.79) (p = 0.21)	Log-PFOA and log-T4: Beta = 0.38 (-0.07, 0.83) (p = 0.97) Log-PFOA and log-FT4: Beta = 0.016 (-0.036, 0.069) (p = 0.54)
Melzer et al. 2010 United States, NHANES 1999–2000, 2003–2004, and 2005–2006 n = 3,974 adults, ages ≥ 20 yrs Linear regression, stratified by gender, adjusted	Men (µg/mL) Q1: 0.0001–0.0036 Q2: 0.0037–0.0052 Q3: 0.0053–0.0072 Q4: 0.0073–0.0459 Similar cut-points in women	Thyroid Disease, self-reported, with medication use: Men Women 1 (referent) 1 (referent) 1.17 (0.64–2.15) 0.98 (0.65–1.50) 0.58 (0.21–1.59) 1.09 (0.66–1.81) 1.58 (0.79–3.16) 1.63 (1.07–2.47)		
Wen et al. 2013 United States, NHANES 2007-2008, 2009-2010 n = 1181, adults, aged ≥ 20 yrs Linear regression, adjusted, with sampling weights	Mean 0.004 µg/mL	Beta (95% CI) (p-value) Ln-PFOA and ln-TSH: Men 0004 (-0.081, 0.090) (p = 0.92) Women -0.030 (-0.2157, 0.154) (p = 0.73)	Beta (95% CI) (p-value) Ln-PFOA and ln-T3: Men 0.775 (-3.048, 4.598) (p = 0.67) Women 6.628 (0.545, 12.7) (p = 0.035) Ln-PFOA and ln-FT3: Men 0.016 (0.001, 0.031) (p = 0.04) Women 0.027 (0.009, 0.044) (p = 0.002)	Beta (95% CI) (p-value) Ln-PFOA and ln-T4: Men 0.000 (-0.28, 0.28) (p = 1.0) Women 0.082 (-0.369, 0.532) (p = 0.71) Ln-PFOA and ln-FT4: Men -0.010 (-0.041, 0.022) (p = 0.53) Women -0.004 (-0.047, 0.039) (p = 0.83)

Table 3-8. Summary of Epidemiology Studies of PFOA and Thyroid Effects in Special Populations

Reference and Study Details	PFOA Level	TSH	T3	T4
Children: High-Exposure Community				
Lopez-Espinosa et al. 2012 n = 10,725 children, aged 1-17 yrs C8 Health Project Reported thyroid disease based on parent- report of health care provider diagnosis of thyroid disease (and specific types); also included current use of thyroid medications Subclinical disease based on hormone levels excluding people with self-reported thyroid disease or taking thyroid medication (subclinical hypothyroidism = above age-specific reference range for TSH and total T4 within reference range; subclinical hyperthyroidism = below age-specific reference range for TSH and total T4 within or above reference range)	Modeled <i>in utero</i> PFOA: median 0.012 µg/mL Measured in children: median 0.0293 µg/mL	Beta (95% CI) for % change in TSH per IQR ln-PFOA: in utero -0.5 (-2.4, 1.5) in child 1.0 (-0.5, 2.7)	Not measured	Beta (95% CI) for % change in total T4 per IQR ln-PFOA: in utero -0.1 (-0.8, 0.6) in child 0.1 (-0.5, 0.6)
OR (95% CI) for thyroid disease per IQR ln-PFOA:				
<i>in utero</i> PFOA:				
Child's PFOA:				
Any thyroid disease (n = 27) 1.45 (0.95, 2.27) (n = 61) 1.44 (1.02, 2.03)				
Hypothyroidism (n = 20) 1.61(0.96, 2.63) (n = 39) 1.54 (1.00, 2.37)				
Subclinical hypothyroidism (n = 155) 0.94 (0.76, 1.16) (n = 365) 0.98 (0.86, 1.15)				
Subclinical hyperthyroidism (n = 31) 1.10 (0.69, 1.74) (n = 78) 0.81 (0.58, 1.15)				
Associations with any thyroid disease and hypothyroidism were not seen with PFOS				
Children: General Population Studies				
de Cock et al. 2014 Netherlands n = 83 newborns PFOA in cord blood samples T4 in heel prick blood Linear regression, stratified by gender; PFOA quartiles, adjusted	0.943 µg/L 0.000943 µg/mL	Not measured	Not measured	Beta T4 (nmol/L) (95% CI) Boys Q1: Referent Q2: 7.9 (-18.04, 33.92) Q3: -2.1 (-20.94, 16.7) Q4: 6.2 (-16.08, 28.50) Girls Q1: Referent Q2: -5.9 (-26.75, 14.94) Q3: 11.8 (-19.08, 42.72) Q4: 38.6 (13.34, 63.83)
Lin et al. 2013 Taiwan, Young Taiwanese Cardiovascular Cohort Study n = 545 (45 with elevated blood pressure); n = 18 hypothyroid- TSH > normal range Aged: 12-30 yrs	Geometric mean 0.00267 µg/mL Q1: <0.00364 Q2: 0.00364 – ≤0.00066 Q3: 0.00666 - ≤0.00971 Q4: >0.009.71	Mean (±SE) Ln TSH by PFOA quartile (adjusted) Q1: 0.48 (± 0.08) Q2: 0.45 (± 0.09) Q3: 0.36 (± 0.11) Q4: 0.41 (± 0.12) No association with risk of hypothyroidism	Not measured	Mean (±SE) free T4 by PFOA quartile (adjusted) Q1: 1.07 (± 0.01) Q2: 1.08 (± 0.02) Q3: 1.10 (± 0.02) Q4: 1.06 (± 0.02)

Reference and Study Details	PFOA Level	TSH	T3	T4
Pregnant Women: General Population Studies				
Chan et al. 2011 Canada n = 96 hypothyroxinemia cases (normal TSH with decreased free T4 – below 10 th percentile) and 175 controls (normal TSK and free T4 in 50 th –90 th percentile; matching based on referring physician and maternal age) 2 nd trimester blood sample (mean 18 weeks) Conditional logistic regression, adjusted PFOA-PFOS correlation $r = 0.5$	Geometric mean 0.00135 µg/mL	Ln PFOA OR (95% CI): 0.94 (0.74–1.18) With additional adjustment for PFOS and PFHxS: 0.87 (0.63–1.19)		
Wang et al. 2013 Norway (from case-control study of subfecundity in the Norwegian Mother and Child Cohort Study; cases and controls combined) n = 903 women 2 nd trimester blood sample (mean 18 weeks) Linear regression, adjusted	Median 0.00215 µg/mL	PFOA and ln-TSH Beta (95% CI) –0.0001 (–0.045, 0.044)	Not measured	Not measured
Berg et al. 2015 Norway, Northern Norway Mother and Child Contaminant Cohort Study n = 375 2 nd trimester blood sample (18 weeks) Thyroid hormones and anti-TPO antibodies measured at 18 weeks gestation and at day 3 and week 6 after delivery Mixed effects linear models Repeated measures of thyroid hormone levels were used in model PFOA-PFOS correlation $r = 0.65$	Median 0.00153 µg/mL	Highest quartile PFOA associated with higher TSH, but not significant when adjusted for PFOS (quantitative results not reported)	Quantitative results not reported (noted as no association)	Quantitative results not reported (noted as no association)
Webster et al. 2014 Canada (Vancouver Chemicals Health and Pregnancy Study) n = 152, not taking thyroid medicine 2 nd trimester blood samples (15 and 18 weeks) Mixed effects linear models, stratified by TPO antibody levels PFOA-PFOS correlation $r = 0.71$	Median 0.0017 µg/mL	Beta per IQR PFOA and TSH, (95% CI) (p-value) Normal TPO antibody 0.07 (-0.1, 0.2) (p = 0.41) High TPO antibody 0.7 (0.09, 1) (p = 0.02) Similar results for PFOS [IQR PFOA = 0.0014 µg/mL]	not measured	Beta per IQR PFOA and FT4, (95% CI) (p-value) Normal TPO antibody –0.03 (-0.3, 0.2) (p = 0.82) High TPO antibody –0.4 (-1, 0.5) (p = 0.35) [IQR PFOA = 0.0014 µg/mL]

In an expanded and refined analysis of the data reported in Olsen et al. 2003, Olsen and Zobel (2007) looked at the relationship between serum PFOA concentration and TSH, serum and free T4, and T3 levels in workers at the Decatur, Antwerp, and Cottage Grove production plants. The fluorochemical workers consisted of males (aged 21–67) from the Antwerp, Belgium (n = 196); Cottage Grove, Minnesota (n = 122); and Decatur, Alabama (n = 188) production facilities who volunteered to participate in the medical surveillance program in 2000. The mean serum PFOA concentration was 2.21 µg/mL for all sites combined. No association between TSH, serum T4, and PFOA concentration was observed. A negative association (p<0.01) between free T4 and serum PFOA concentration was observed in the unadjusted and adjusted (age, BMI, and alcohol consumption) models for all locations combined; no association was observed for the individual locations. A positive association (p<0.05) was observed between T3 and serum PFOA concentration in the unadjusted and adjusted models for all locations combined, the Antwerp plant, and the Decatur plant. The authors noted that the results were not considered clinically relevant because the results were within normal reference range. Steenland et al. (2015) did not find an association between self-reported thyroid disease and PFOA levels among 3,713 workers at the Washington Works plant in West Virginia who participated in the C8 Health Project.

Two studies measured thyroid hormones in PFOA-exposed workers, but did not present an analysis of the relation between PFOA exposure and hormone levels. Both studies noted that the thyroid hormone values were in the normal range (Costa et al. 2009; Sakr et al. 2007a).

High-exposure community studies. Emmett et al. (2006) examined the association of serum PFOA with thyroid disease in 371 residents of the Little Hocking, Ohio, water district as described previously. No association was observed between serum PFOA and thyroid disease. Serum PFOA was decreased (not significantly different) in subjects with self-reported disease (e.g., hyperthyroidism, goiter or enlarged thyroid, hypothyroidism) (0.387 µg/mL; n = 40) compared to subjects without thyroid disease (0.451 µg/mL; n = 331). No association was seen between serum PFOA and TSH when analyzed with linear regression or by t-test comparison of PFOA in the abnormal TSH (n = 24, 6%) and normal TSH groups (p = 0.59).

Participants in the C8 Health Project were examined for an association between PFOA levels and thyroid disease (Winquist and Steenland 2014b). The cohort included 28,541 community members and 3,713 workers who had completed study questionnaires during 2008–2011. The median serum PFOA level at enrollment in 2005–2006 was 0.0261 µg/mL for the combined cohort, 0.0242 µg/mL for the community members, and 0.1127 µg/mL for the workers. Retrospective serum levels for the community cohort, estimated from air and water concentrations, residential history, and water consumption rates, were used to estimate yearly intakes. For the workers, yearly serum estimates were modeled from work history information and job-specific concentrations. Cox proportional hazard models, stratified by birth year, were used to assess self-reported adult thyroid disease hazard in relation to time-varying yearly or cumulative (sum of yearly estimates) estimated PFOA serum concentration, controlling for gender, race, education, smoking, and alcohol consumption. For the combined cohort, quintiles for yearly exposure were 0.00011–<0.0047, 0.0047–<0.00849, 0.00849–<0.0216, 0.0216–<0.100, and 0.100–3.303 µg/mL; quintiles for cumulative exposure were 0.0001–<0.115, 0.115–<0.202, 0.202–<0.497, 0.497–2.676, and 2.676–97.396 µg/mL·year. As expected, the number of thyroid disease cases was higher among females than among males. Positive associations were seen with the cumulative exposure and the per-year exposure metrics for incidence of all thyroid disease (as well as for specific subtypes), with the observations seen primarily in females

(Table 3-7). When limited to disease occurring after the 2005–2006 serum collection, the number of incident cases was reduced from 2,008 to 454, and the patterns of associations were more variable. No associations between estimated serum PFOA level and thyroid disease were found in the analysis limited to workers in this study population (Steenland et al. 2015).

The C8 Science Panel (2012) used data from the C8 general population cohort and concluded that there is a probable link between PFOA and thyroid disease.

General population studies. Bloom et al. (2010) investigated the associations between serum PFAS, including PFOA, and TSH and free thyroxine (FT4). The serum samples came from 31 participants (27 males, 4 females; mean age 39 years) of the 1995–1997 New York State Angler Cohort Study Dioxin Exposure Substudy. The study subjects each completed a questionnaire and provided a blood sample for serum analysis. The questionnaire contained questions about sport-fish and game consumption, lifestyle, demographic factors, and medical history. The serum samples were analyzed for TSH and FT4 in 2003 by immunometric chemiluminescent sandwich assay and for PFAS in 2006 by ion pair extraction high-performance LC-MS/MS. Regression models were used to analyze the data and adjust for confounders. No subjects reported use of thyroid medication or physician-diagnosed goiter or thyroid conditions. Mean TSH concentration (range 0.43–15.70 $\mu\text{IU/mL}$) was within normal range (0.40–5.00 $\mu\text{IU/mL}$) with the exception of one subject. Mean FT4 (0.90–1.55 ng/dL) was within normal range (0.80–1.80 ng/dL) for all subjects. The mean serum PFOA concentration was 0.00133 $\mu\text{g/mL}$ and ranged from 0.00057 to 0.00258 $\mu\text{g/mL}$. The males had a significantly higher serum PFOA concentration than the females (0.00147 $\mu\text{g/mL}$ versus 0.00105 $\mu\text{g/mL}$; $p = 0.047$). There was no association between serum PFOA concentration (or PFOS) and TSH or FT4.

The relationship between serum levels of PFOA, PFOS and other persistent organic pollutants and thyroid biomarkers was investigated in older adults (Shrestha et al. 2015). Levels of TSH, FT4, T4, and T3 were measured in 51 males and 36 females with a mean age of 63.6 years. None of the participants had thyroid disease or were taking thyroid medication. Covariates in the analysis included age, gender, education level, the sum of polychlorinated biphenyls (ΣPCBs) and polybrominated diphenyl ethers (ΣPBDEs), smoking status, and alcohol consumption. The mean PFOA serum level was $0.0104 \pm 0.0057 \mu\text{g/mL}$ for all participants. In both unadjusted and adjusted models, PFOA was significantly ($p < 0.05$ or 0.01) and positively associated with T4 and T3; a possible dose-response was not evaluated in this small sample. A statistical interaction was detected between age and PFOA for effects on FT4 and T4 suggesting that the positive associations of PFOA were potentiated by age. PFOS was also positively associated with FT4 and T4.

Melzer et al. (2010) examined the association between serum PFOA concentration and thyroid disease in the general population of the United States by analyzing data from the 1999–2000, 2003–2004, and 2005–2006 NHANES. The population included 3,966 adults (2,066 females, 1,900 males) older than 18 years. Each of the participants answered a questionnaire, had a physical examination, and provided blood and urine samples for analysis. Serum samples were analyzed for PFOA concentration by solid-phase extraction coupled to isotope dilution/high-performance LC-MS/MS. Data on diseases diagnosed by a physician and confounding factors, including year of NHANES, age, gender, race/ethnicity, education, smoking status, BMI, and alcohol consumption were obtained from the questionnaire. Individuals were considered to have thyroid disease if they responded on the questionnaire to having a physician-diagnosed disease or if they were taking medication for either hypothyroidism or hyperthyroidism.

Regression models were used to analyze the data and adjust for confounders. Serum PFOA concentration was divided into quartiles for each gender. In females, serum PFOA concentration ranged from 0.0001–0.123 µg/mL (Q1 = 0.0001–0.0026; Q2 = 0.0027–0.004; Q3 = 0.0041–0.0057; Q4 = 0.0057–0.123), and in males, serum PFOA concentration ranged from 0.0001–0.0459 µg/mL (Q1 = 0.0001–0.0036; Q2 = 0.0037–0.0052; Q3 = 0.0053–0.0072; Q4 = 0.0073–0.0459). Females in PFOA Q4 were more likely to report current thyroid disease [OR = 2.24, 95% CI: 1.38–3.65, $p = 0.002$] compared to females in Q1 and Q2. No association between serum PFOA concentration and thyroid disease was observed in males. With PFOS, the opposite was found, with males in the highest quartile, but not females, more likely to report thyroid disease. Data interpretation was limited by the cross-sectional study design, lack of information on the specific thyroid disorder diagnosis in the questionnaire responses, and single serum samples for PFOA measurements taken at the same time disease status was ascertained through the questionnaire. Thus, the possibility of reverse causality cannot be eliminated.

Another study of 1,181 members of NHANES for survey years 2007–2008 and 2009–2010 examined the association between serum PFOA levels (and 12 other PFASs) and thyroid hormone levels (Wen et al. 2013). Multivariable linear regression models were used with serum thyroid measures as the dependent variable and individual natural log-transformed PFAS concentration as a predictor along with confounders. The geometric mean serum PFOA level was 0.00415 µg/mL. A positive association between PFOA level and free T3 (FT3) was found in females as a 1-unit increase in natural log-serum PFOA increased serum total T3 concentration by 6.628 ng/dL (95% CI 0.545, 12.712, $p = .035$). However, the association was no longer significant when PFOS, PFNA, and PFHxS levels were included in the model.

A different type of examination was undertaken by Pirali et al. (2009). The study measured intrathyroidal levels of PFOA (and PFOS) in thyroid surgical specimens to determine if a relationship existed between PFOA and the clinical, biochemical, and histological phenotype of thyroid disease patients. Serum PFOA concentration also was measured to determine if a relationship existed between thyroid tissue and serum PFOA levels. Patients ($n = 28$; 8 males, 20 females; 33–79 years) with benign multinodular goiters ($n = 15$), Graves' disease ($n = 7$), malignant papillary carcinoma ($n = 5$), and malignant follicular carcinoma ($n = 1$) were included in the study. Informed consent, clinical examination, work history, thyroid hormone and antibody measurements, thyroid ultrasound, fine-needle aspiration of nodules greater than 1 cm, and serum samples ($n = 21$) were performed or collected prior to surgery. The control group consisted of thyroid tissues collected at autopsy from subjects with no history of thyroid disease ($n = 7$; 5 males, 3 females; 12–83 years) and serum samples from 10 subjects with no evidence of thyroid disease. The student's t-test, Mann-Whitney U-test, Pearson and Spearman's correlation tests, and chi-square test with Fisher's correction were used to compare group results. Regression analysis was used to test the effect of different variables independently of a covariate.

The median concentration of PFOA in thyroid tissue was 2.0 ng/g (range = 0.4–4.6 ng/g). The patients were divided into three different groups: group I (toxic and nontoxic multinodular goiter, $n = 12$), group II (differentiated thyroid cancer, $n = 6$), and group III (Hashimoto's thyroiditis or Graves' disease, $n = 10$). Thyroid PFOA concentration for the control group, group I, group II, and group III ranged from 1.0–6.0, 0.4–4.4, 1.4–4.0, and 1.0–4.6 ng/g, respectively. Serum PFOA concentration for the control group, group I, group II, and group III ranged from 0.004–0.0137, 0.0012–0.0166, 0.0051–0.0096, and 0.0039–0.0125 µg/ml, respectively. The concentration of PFOA in the thyroid and serum was similar between control and thyroid patients at the time of measurement. Age, gender, residence, working activity, malignant /

nonmalignant conditions, antibodies, thyroid hormone concentrations, and ultrasound parameters were not associated with thyroid or serum PFOA concentration. There also was no correlation between serum and thyroid PFOA concentration. Similar results were obtained with PFOS.

Children. Three studies evaluated thyroid function in children (or children and young adults) (Table 3-8). In the children from the C8 cohort who were highly exposed to PFOA, Lopez-Espinosa et al. (2012) observed positive associations between prenatal PFOA (modeled maternal levels) and any thyroid disease or clinical hypothyroidism; similar results were seen with the child's PFOA level. Associations were not seen with subclinical hypothyroidism or hyperthyroidism, or TSH or total T4 levels among children without thyroid disease. In a study from the Netherlands of 52 males and 31 females, increasing T4 levels in females were associated with increasing prenatal PFOA concentrations (as measured in cord blood samples) (de Cock et al. 2014); no associations were reported in males. A study of adolescents and young adults (aged 12–30 years) from Taiwan did not observe associations between serum PFOA concentrations and TSH or T4 levels (Lin et al. 2013).

Pregnant females. Several studies of thyroid have been conducted in pregnant females (Table 3-8), mostly reporting null associations between maternal PFOA concentration and thyroid status during pregnancy (Berg et al. 2015; Chan et al. 2011; Wang et al. 2013). The exception to these results is the only study that included an analysis stratified by presence of antithyroid peroxidase (anti-TPO) antibodies (Webster et al. 2014), in which associations between PFOA and TSH were seen only among females with high autoantibody levels. This finding supports the importance of further research into the association between PFOA and autoimmunity and autoimmune conditions.

Chan et al. (2011) examined the association between hypothyroxinemia and serum PFOA concentration (and PFOS) in pregnant Canadian females ($n = 271$; 20.1–45.1 years of age, ≥ 22 weeks of gestation) in a matched case-control study. Maternal serum from the second trimester was collected between December 15, 2005, and June 22, 2006, as part of an elective prenatal screen for birth defects. Serum samples were analyzed for TSH and FT4 concentrations and PFOA. The cases of hypothyroxinemia ($n = 96$) had normal TSH concentrations and FT4 concentrations in the lowest 10th percentile (≤ 8.8 pmol/L). The controls ($n = 175$) had normal TSH concentrations and FT4 concentrations between the 50th and 90th percentiles (12–14.1 pmol/L). Maternal age, weight, and gestational age at blood draw and dichotomized at 50th percentiles were included as confounders, and race was included as a covariate. Chi-square tests and regression models were used to analyze the data. Overall, the geometric mean PFOA level was 0.00135 $\mu\text{g}/\text{mL}$. Statistical comparisons used the geometric mean serum PFOA concentration in the cases of 3.10 nmol/L and 3.32 nmol/L in the controls. There was no association between serum PFOA concentration (or PFOS) and hypothyroxinemia in pregnant females.

A cross-sectional study of 903 pregnant females evaluated the association between plasma PFOA levels and plasma TSH (Wang et al. 2013). Twelve other PFASs also were quantified and evaluated. The females were a cohort of the Norwegian Mother and Child Cohort Study and the blood samples were drawn at approximately week 18 of gestation. The median PFOA concentration was 0.0022 $\mu\text{g}/\text{mL}$ with an interquartile range of 0.00157–0.00295 $\mu\text{g}/\text{mL}$. No association was found between plasma levels of PFOA and TSH. PFOS was associated with higher TSH levels, but plasma levels of other PFASs were unrelated to TSH.

Expanding on the above study, Berg et al. (2015) investigated the association between a number of PFASs, including PFOA, and TSH, T3, T4, FT3, and FT4. A subset of 375 females in the Norwegian Mother and Child Cohort Study with blood samples at about gestational week 18 and at 3 days and 6 weeks after delivery were included. Seven compounds were detected in more than 80% of the blood samples, with PFOS present in the highest concentration followed by PFOA. The median PFOA level was 0.00153 µg/mL, and the females were assigned to quartiles based on the first blood sample at week 18 of gestation. Females in the highest quartile had significantly higher mean TSH than females in the first quartile; however, when PFOS concentration was included as a covariate, the association was not significant.

A study of Canadian females (n = 152) evaluated maternal serum PFOA levels (and PFHxS, PFNA, and PFOS) for associations with thyroid hormone levels during the early second trimester of pregnancy, weeks 15–18 (Webster et al. 2014). Mixed effects linear models were used to examine associations between PFOA levels and FT4, total T4, and TSH; associations were made for all females and separately for females with high levels of TPO antibody, a marker of autoimmune hypothyroidism. Median serum PFOA was 0.0017 µg/mL. No associations were found between levels of PFOA (or PFOS and PFHxS), and thyroid hormone levels in females with normal antibody levels. PFNA was positively associated with TSH. Clinically elevated TPO antibody levels were found in 14 (9%) of the study population. In the females with high antibody levels, PFOA, as well as PFNA and PFOS, was strongly and positively associated with TSH. An IQR increase in maternal PFOA concentrations was associated with a 54% increase in maternal TSH compared to the median TSH level. PFNA and PFOS concentrations were associated with 46% and 69% increases, respectively, in maternal TSH.

As illustrated above, numerous epidemiology studies have evaluated thyroid function and/or thyroid disease in association with serum PFOA concentrations (Tables 3-7 and 3-8). As noted previously, thyroid disease is more common in females. Several studies provide support for an association between PFOA exposure and incidence or prevalence of thyroid disease, and include large studies of representative samples of the general U.S. population (Melzer et al. 2010) and the high-exposure C8 community population (Lopez-Espinosa et al. 2012; Winquist and Steenland 2014b). Two of these studies are of adults (Melzer et al. 2010; Winquist and Steenland 2014b) and one is of children/adolescents (Lopez-Espinosa et al. 2012). The trend for an association with thyroid disease was seen in females in the C8 population (Winquist and Steenland 2014b) and the general population (Melzer et al. 2010), and in children (Lopez-Espinosa et al. 2012); this was most often hypothyroidism. Association between PFOA and TSH also was seen in pregnant females with anti-TPO antibodies (Webster et al. 2014). In contrast, generally null associations were found between PFOA and TSH or thyroid hormones (T3 or T4) in people who have not been diagnosed with thyroid disease.

3.1.1.7 Diabetes and Related Endpoints

Occupational exposure studies. Leonard et al. (2008) examined cause of death among former workers at the DuPont Washington Works plant in West Virginia. The cohort consisted of 6,027 employees (4,872 males and 1,155 females) who had worked at the plant from 1948 through 2002. The DuPont Epidemiology Registry and U.S. National Death Index were used to obtain causes of death. SMRs were estimated using three reference populations; the populations of the United States and West Virginia and the DuPont regional worker reference population excluding workers at the Washington Works plant. A significant increase in diabetes mortality was observed for Washington Works plant workers compared to the DuPont regional worker

reference population [SMR = 197, 95% CI: 123, 298]. However, no regression analyses were done with PFOA levels.

The Leonard et al. study (2008) was updated in a cohort mortality study conducted by Steenland and Woskie (2012) to include 5,791 individuals who had worked at the DuPont West Virginia plant for at least 1 year between 1948 and 2002. Mean duration of employment was 19 years. Deaths through 2008 were ascertained through either the National Death Index or death certificate data. Exposure quartiles were assessed by estimated cumulative annual serum levels based on blood samples from 1,308 workers taken during 1979–2004 and time spent in various job categories (ppm-years). Referent groups included both nonexposed DuPont workers in the same region and the U.S. population. Overall, the mean cumulative exposure was 7.8 ppm-years and the estimated average annual serum level was 0.35 µg/mL. Compared to the referent rates from other DuPont workers, cause-specific mortality rates were elevated for diabetes (n = 38; SMR=1.90; 95% CI 1.35, 2.61). These data are limited by the small number of cases and the restriction to mortality as an outcome.

The most recent report on the above cohort included 6,026 workers evaluated for disease incidence, not just mortality (Steenland et al. 2015). Lifetime serum cumulative dose was estimated by combining occupational and nonoccupational exposures. Median measured serum level was 0.113 µg/mL based on samples collected in 2005. No association was found between PFOA level and type II diabetes incidence rate.

High-exposure community studies. MacNeil et al. (2009) examined the association of PFOA with type II diabetes in adult participants of the C8 Health Project (n = 54,468; age 20 to >80 years). Serum PFOA concentration was divided into deciles using the population distribution. Other PFAS were not evaluated in this study. Serum PFOA (deciles), BMI, gender, family history of diabetes, race, use of cholesterol-lowering medicine, and use of blood pressure-lowering medicine were used to analyze the data in categorical and logistic regression models for the outcome of type II diabetes. Serum fasting glucose levels were the focus for a linear regression analysis of the study population (n = 21,643) excluding type II diabetics and those who had provided nonfasting blood samples. The mean serum PFOA concentration for the entire study population was 0.0868 µg/mL and 0.0913 µg/mL for subjects with type II diabetes validated by medical review (n = 3,539).

There was no association between serum PFOA concentration and fasting serum glucose level in subjects characterized as nondiabetic. The mean serum PFOA concentration was 0.0929 µg/mL in subjects who self-reported type II diabetes (n = 4,278) and 0.1227 µg/mL in subjects diagnosed in the last 10 years (n = 1,055). No association was observed between type II diabetes and serum PFOA concentration. The OR by decile was 1.00, 0.71, 0.60, 0.72, 0.65, 0.65, 0.87, 0.58, 0.62, and 0.72. The results of the analysis indicated that PFOA exposure is not associated with type II diabetes among the population studied. Data interpretation was limited by the cross-sectional study design, which made it difficult to determine if PFOA exposure preceded disease.

The C8 Science Panel (2012) combined these data from the C8 general population cohort with follow-up data and data from worker cohorts, and concluded that there is no probable link between PFOA and type II diabetes.

General population studies. Preconception serum levels of PFOA (and other PFASs) were evaluated in females attempting pregnancy in relation to risk of developing gestational diabetes

(Zhang et al. 2015). The 258 participants were members of the Longitudinal Investigation of Fertility and the Environment (LIFE) study with blood samples taken during 2005–2009. The ORs and 95% CIs of gestational diabetes associated with each SD increment of preconception serum PFOA concentration (log-transformed) (and six other PFASs) were estimated with the use of logistic regression after adjusting for confounders. Preconception mean serum PFOA levels were 0.0033 µg/mL for the entire cohort, 0.00394 µg/mL in females with gestational diabetes and 0.00307 µg/mL in females without gestational diabetes. A significant positive association was found between PFOA and risk of gestational diabetes in the fully adjusted model (OR=1.86; 95% CI 1.14, 3.02). Associations for six other PFAS were slightly increased (e.g., PFOS OR=1.13), but did not attain statistical significance.

Metabolic syndrome is a combination of medical disorders and risk factors that increase the risk of developing cardiovascular disease and diabetes. Lin et al. (2009) investigated the association between serum PFOA (plus three other PFASs) and glucose homeostasis and metabolic syndrome in adolescents (aged 12–20 years) and adults (aged >20 years) by analyzing the 1999–2000 and 2003–2004 NHANES data. The National Cholesterol Education Program Adult Treatment Panel III guidelines were used to define adult metabolic syndrome and the modified guidelines were used to define adolescent metabolic syndrome. The study population included 1,443 subjects (474 adolescents, 969 adults) at least 12 years of age who had a morning examination and triglyceride measurement. There were 266 male and 208 female adolescents and 475 male and 493 female adults. Multiple linear regression and logistic regression models were used to analyze the data. Covariates included age, gender, race, smoking status, alcohol intake, and household income. Log-transformed PFOA concentration was 1.51 and 1.48 ng/mL for adolescents and adults, respectively. In adults, serum PFOA concentration was associated with increased β -cell function (β coefficient 0.07, $p < 0.05$). Serum PFOA concentration was not associated with metabolic syndrome, metabolic syndrome waist circumference, glucose concentration, homeostasis model of insulin resistance, or insulin levels in adults or adolescents. Both PFOS and PFNA were positively associated with some of the endpoints associated with metabolic syndrome.

Nelson et al. (2010) examined the relationship between polyfluoroalkyl chemical serum concentration, including PFOA, and insulin resistance as previously described for data from NHANES. Fasting insulin and fasting glucose were used to determine the homeostatic model assessment for insulin resistance. No association was found between serum PFOA concentration, or any other PFAS, and insulin resistance.

Overall, these studies show a lack of association of PFOA with diabetes, metabolic syndrome, and related endpoints.

3.1.1.8 Reproductive and Developmental Endpoints

Several studies have examined the relationship between PFOA exposures and reproductive, gestational, and developmental endpoints as well as postnatal growth and maturation in humans. Pregnancy-related endpoints include gestational age (Nolan et al. 2009), measures of fetal growth (Apelberg et al. 2007; Fei et al. 2007, 2008a; Monroy et al. 2008; Nolan et al. 2009; Stein et al. 2009; Washino et al. 2009), miscarriage or preterm birth (Stein et al. 2009), birth defects (Stein et al. 2009), hypertension and preeclampsia (Darrow et al. 2013; Savitz et al. 2012a, 2012b; Stein et al. 2009), and fecundity (Fei et al. 2009; Vélez et al. 2015). Infant growth and development during the first 7 years (Andersen et al. 2010, 2013; Fei et al. 2008b, 2010a, 2010b; Høyer et al. 2015b) and postnatal growth and maturation, including neurodevelopment (Fei and

Olsen 2011; Hoffman et al. 2010; Høyer et al. 2015a; Liew et al. 2014; Stein et al. 2013) and risk of adult obesity (Halldorsson et al. 2012) also have been studied. Male reproductive endpoints evaluated in humans include sperm count and semen quality (Buck Louis et al. 2015; Joensen et al. 2009, 2013; Vested et al. 2013). Female pubertal development was examined in three studies (Christensen et al. 2011; Kristensen et al. 2013; Lopez-Espinosa et al. 2011). As noted previously, the focus of this review is on pregnancy-related outcomes, specifically pregnancy-related hypertension and preeclampsia, measures of fetal growth, and pubertal development. Within each section, the discussion is divided into occupational exposure studies (if applicable), the C8 high-exposure community studies, and general population studies.

Several analyses are based on the Danish National Birth Cohort (Andersen et al. 2010, 2013; Fei et al. 2007, 2008a, 2008b, 2009, 2010a, 2010b; Fei and Olsen 2011). The females (n = 1,400) and their infants were randomly selected, and the study included those who provided their first blood samples between gestational weeks 4 and 14 and gave birth to a single live-born child without congenital malformation. The females participated in telephone interviews—at 12 and 30 weeks gestation, when the children were 6 and 18 months of age, and when the children were 7 years of age—and filled out a food frequency questionnaire. As the children aged, more questionnaires were completed by the mothers with regard to behavioral health and motor coordination. Highly structured questionnaires were used to gather information on possible confounders, including infant gender, maternal age, parity, socio-occupational status, prepregnancy BMI, and smoking during pregnancy. The National Hospital Discharge Register was used to obtain birth weight, gestational age, placental weight, birth length, head and abdominal circumference data, Apgar scores based on heart rate, respiratory effort, reflex, irritability, muscle tone, and skin color. Plasma PFOA concentration was determined from the first blood samples of 1,399 females, from the second blood samples of 200 females, and from cord blood samples of 50 infants by solid-phase extraction high-performance LC-MS/MS. PFOA concentrations were divided into quartiles (Fei et al. 2009, 2010b), with the lowest quartile designated as the reference group, as follows: <lower limit of quantification– (LLOQ–) 0.00390, 0.00391–0.00520, 0.00521–0.00696, and ≥ 0.00697 $\mu\text{g/mL}$. Regression models were used to analyze the data. Results of these studies are included in the following discussion of results for specific endpoints.

Pregnancy-related hypertension and preeclampsia. There are no occupational exposure and general population studies examining pregnancy-related hypertension and preeclampsia in relation to PFOA exposure. The only data available come from the high-exposure C8 Health Project study population (Table 3-9).

Several studies, using different designs and exposure measures, have examined birth outcomes, including pregnancy-induced hypertension or preeclampsia in infants born to mothers in the high-exposure C8 community population in West Virginia and Ohio (information obtained from questionnaire-based pregnancy histories or from linkage to birth records) (Table 3-9). Stein et al. (2009) used an exposure measure based on individual serum PFOA levels obtained in the 2005–2006 baseline survey to examine birth outcomes (based on self-report) in 1,845 births in the 5 years preceding the PFOA measurement. Savitz et al. (2012a, 2012b) included births from 1990 to 2004, modeling exposure based on the serum measurements in 2005, information obtained in the 2005 baseline questionnaire regarding residential history, information on historical environmental releases, and PKs. In one of the analyses (study II in Savitz et al. 2012b), linkage with birth records was used to verify the preeclampsia outcome.

Table 3-9. Summary of Epidemiology Studies of PFOA and Pregnancy-Induced Hypertension or Preeclampsia

Study	PFOA Level	Results
Stein et al. 2009 United States (C8 Health Project) n = 1,845 pregnancies in the 5 years before enrollment Exposure based on serum collected in 2005 Outcome based on pregnancy history collected in 2005	Median 0.0212 µg/mL	OR (95% CI), preeclampsia per IQR (lnPFOA) increase in PFOA: 1.1 (0.9, 1.3) [IQR(lnPFOA)=0.0395 µg/mL] < 50 th percentile 1.0 (referent) ≥ 50 th 1.3 (0.9, 1.9) < 50 th percentile 1.0 (referent) 50-75 th 1.5 (1.0, 2.3) 75-90 th 1.2 (0.7, 2.1) > 90 th 0.9 (0.5, 1.8)
Savitz et al. 2012a United States (C8 Health Project) n = 11,737 pregnancies in 1990-2006 Modeled exposure based on serum collected in 2005, residential history, and other data Outcome based on pregnancy history collected in 2005		OR (95% CI), preeclampsia per IQR(lnPFOA) increase in PFOA: 1.13 (1.00–1.28) [IQR (lnPFOA)=0.00219 µg/mL] per 0.100 µg/mL increase in PFOA: 1.08 (1.01–1.15) < 40 th percentile 1.0 (referent) 40-60 th 1.2 (1.0, 1.5) 60-80 th 1.1 (0.9, 1.4) ≥ 80 th 1.2 (1.0, 1.6) Also noted stronger associations with Bayesian calibration of exposure and among women with highest quality residential history
Savitz et al. 2012b United States (C8 Health Project) n = 4,547 pregnancies in 1990-2004 Modeled exposure based on serum collected in 2005, residential history, and other data Outcome based on linkage to birth records	Median 0.0134 µg/mL	With Bayesian calibration of exposure: OR (95% CI) per IQR (lnPFOA) increase in PFOA: 1.13 (0.92, 1.37) [IQR (lnPFOA)=0.00192 µg/mL] per 0.100 µg/mL increase in PFOA: 0.97 (0.85, 1.11) < 40 th percentile 1.0 (referent) 40-60 th 1.0 (0.7, 1.4) 60-80 th 1.5 (1.1, 2.1) ≥ 80 th 1.2 (0.8, 1.7)
Darrow et al. 2013 United States (C8 Health Project) n = 1,330 pregnancies in 2005-2010; 770 first pregnancies after PFOA measures; 947 (pregnancies in 2005-2007) Exposure based on serum collected in 2005	Geometric mean 0.016 µg/mL Mean 0.031	OR (95% CI) per log unit increase in PFOA Full analysis: 1.27 (1.05, 1.55) (adjusted for PFOS) 1.22 (0.99, 1.51) By quintile: Q1 up to 0.0069 µg/mL 1.0 (referent) Q2 0.0069 – < 0.0111 2.39 (1.05, 5.46) Q3 0.0111 – < 0.0189 3.43 (1.50, 7.82) Q4 0.0189 – < 0.0372 3.12 (1.35, 7.18) Q5 ≥ 0.0372 3.16 (1.35, 7.38) First pregnancy after PFOA measure 1.23 (0.92, 1.64) Pregnancies in 2005-2007: 1.35 (1.04, 1.76)

Darrow et al. (2013) examined birth outcomes in births that occurred in the 5 years after the PFOA measurement. In this study, reproductive history in a follow-up interview in 2010 was collected from females who had provided serum for PFOA measurement in 2005–2006. Singleton live births among 1,330 females after January 1, 2005, were linked to birth records to identify outcomes of pregnancy-induced hypertension and other outcomes (e.g., preterm birth, low birth weight, and birth weight among full-term infants). Thus there is a progressively greater refinement and reduction in misclassification (or exposure and outcome) among this set of

studies. Each of these studies provides some evidence of an association between PFOA exposure and risk of pregnancy-induced hypertension or preeclampsia, with the most robust findings from the methodologically strongest study (Darrow et al. 2013). Maternal serum PFOA levels were positively associated with pregnancy-induced hypertension, with an adjusted OR per log unit increase in PFOA of 1.27 (95% CI: 1.15, 1.55). PFOS also was positively associated with pregnancy-induced hypertension.

The C8 Science Panel (2012) considered both hypertension and preeclampsia together in determining a link between PFOA and pregnancy-induced hypertension. Some studies conducted by the panel found no associations while others showed positive associations. Among the studies with positive associations, no clear dose response was indicated. However, the panel decided that the evidence was sufficient to conclude that PFOA has a probable link to pregnancy-induced hypertension.

Fetal growth. Many different measures of fetal growth can be used in epidemiology studies. Birth weight is widely available (as it is routinely collected in medical records and birth certificates). Low birth weight (defined as < 2,500 g) can be a proxy measure for preterm birth (particularly when accurate gestational age dating is not available). Other measures of fetal growth such as small for gestation age might more accurately reflect fetal growth retardation.

Both birth weight and gestational age are characterized as two-part distributions, with a larger Gaussian portion representing term births and a longer tail representing preterm births. Increased risks of complications, including infant mortality, are seen in preterm births (or low birth-weight births). When analyzed as a continuous measure, changes in birth weight might not be clinically significant, as small changes in the distribution among term infants do not result in a shift into the distribution seen in preterm infants (Savitz 2007; Wilcox 2010). This consideration differs from that of some other types of continuous measures, such as neurodevelopment scales, blood pressure, or cholesterol, in which shifts in the distribution are expected to move a greater proportion of the population into an “at risk” or “abnormal” level.

High-exposure community studies. As noted in the previous discussion of preeclampsia, several studies using different designs and exposure measures have examined birth outcomes in infants born to mothers in the high-exposure C8 community population in West Virginia and Ohio (Darrow et al. 2013; Nolan et al. 2009; Savitz et al. 2012a, 2012b; Stein et al. 2009). These studies include analyses of birth weight and of low birth weight, and have not observed associations between PFOA and either birth weight among term births or the risk of low birth weight among all (singleton) births (Table 3-10).

Based on these data, as well as continued follow-up of the community cohort, the C8 Science Panel (2012) concluded that there is no probable link between PFOA and low birth weight.

General population studies. Two studies examined associations between maternal PFOA levels and birth weight among term infants (Fei et al. 2007; Monroy et al. 2008). The larger of these is from the Danish National Birth Cohort by Fei et al. (2007) (Table 3-10). In this study of 1,207 term births, the change in birth weight per log unit increase in PFOA was -9 g (95% CI: -20, 2 g).

Table 3-10. Summary of Epidemiology Studies of PFOA and Birth Weight

Study	PFOA Level	Results
<i>High-Exposure Community</i>		
Darrow et al. 2013 United States (C8 Health Project) n = 1,629 pregnancies in 2005-2010; 770 first pregnancies after PFOA measures; 947 (pregnancies in 2005-2007) Exposure based on serum collected in 2005	Geometric mean 0.0162 µg/mL Mean 0.031 µg/mL	Change in birth weight per log unit increase (95% CI) Full analysis: -8 (-28, 12) g (adjusted for PFOS) -4 (-25, 17) g First pregnancy after PFOA measure 5 (-22, 33) g Pregnancies in 2005-2007: -10 (-34, 14) g OR (95% CI) for low birth weight (< 2500 g) per log unit increase Full analysis: 0.94 (0.75, 1.17) (adjusted for PFOS) 0.91 (0.72, 1.16) First pregnancy after PFOA measure 1.07 (0.78, 1.47) Pregnancies in 2005-2007: 0.91 (0.70, 1.17) [Similar results in Nolan et al. 2009; Savitz et al. 2012a, 2012b; Stein et al. 2009]
<i>General Population: Birth Weight Among Term Births</i>		
Fei et al. 2007 Denmark n = 1,207 (term births) Blood sample at 4-14 weeks	0.0056 µg/mL	Change in birth weight per unit increase (95% CI) -8.7 (-19.5, 2.1)
Monroy et al. 2008 Canada n = 101 Cord blood sample	0.0019 µg/mL (cord blood)	Change in PFOA per g change in birth weight: Beta = 0.000171 (p = 0.65)
<i>General Population: Birth Weight or Low Birth Weight Among All Births (by time of blood collection)</i>		
Fei et al. 2007 Denmark Blood sample at 4-14 weeks n = 1,399 (full sample) 3.8% preterm	0.0056 µg/mL	Change in birth weight per unit increase (95% CI) -10.6 (-20.8, -0.47) g OR (95% CI) for low birth weight (< 2500 g) by quartile Q1 up to 0.00390 µg/mL 1.0 (referent) Q2 0.00391-0.00520 4.3 (0.51, 37) Q3 0.00521-0.00696 3.7 (0.42, 32) Q4 ≥ 0.00697 2.4 (0.27, 22) (Trend p = 0.94)
Hamm et al. 2010 Canada n = 252 Blood sample at 15-16 weeks 8.3% preterm	0.0021 µg/mL	Change in birth weight per ln unit increase (95% CI) -37.4 (-86.0, 11.2) g
Whitworth et al. 2012 Norway n = 849 Blood sample at around 17 weeks 3.9% preterm	0.0021 µg/mL	Change in birth weight z-score per unit increase (95% CI) -0.03 (-0.10, 0.04)
Maisonet et al. 2012 United Kingdom n = 395 Blood sample at 10-28 weeks 3.1% preterm	0.0037 µg/mL	Change in birth weight per log unit increase -34.2 (-54.8, -13) g
Washino et al. 2009 Japan n = 428 Blood sample at 23-35 weeks % preterm not reported	0.0014 µg/mL	Change in birth weight per log unit increase (95% CI) -75 (-191, 42) g

Study	PFOA Level	Results
Apelberg et al. 2007 United States (Baltimore) n = 293 Cord blood sample 13% preterm	0.0016 µg/mL (cord blood)	Change in birth weight per log unit increase (95% CI) -104 (-213, 5) g
Chen et al. 2012 Taiwan n = 429 Cord blood sample 9.3% preterm	0.0018 µg/mL (cord blood)	Change in birth weight per log unit increase (95% CI) -19 (-63, 25) g

Fei et al. (2007, 2008a), and other studies in the general population have examined PFOA in relation to birth weight or risk of low birth weight (or other measures of fetal growth), without restriction to term births (Table 3-10). These studies vary in size from approximately 250 to 1,400 births, and also in terms of timing of exposure measure. Fei et al. (2007, 2008a) used blood samples collected early in pregnancy (4–14 weeks), three studies used samples collected in the second trimester (Hamm et al. 2010; Maisonet et al. 2012; Whitworth et al. 2012), Washino et al. (2009) used samples collected in the third trimester, and two studies used cord blood samples (Apelberg et al. 2007; Chen et al. 2012). These studies also differed in the percent of births that were preterm (ranging from approximately 3% to 13%), and presented results using different types of analyses (i.e., the form of the exposure and outcome variables, continuous, ln-transformed, categorical, etc). Each of the analyses indicates a negative association between PFOA levels and birth weight (i.e., a decrease in birth weight with increase in PFOA), although CIs were wide.

In a systematic review based on the Navigation Guide methods (Woodruff and Sutton 2014), Johnson et al. (2014) identified the general population studies shown in Table 3-10 and the high-exposure C8 Health Project studies published through 2012. The results from the meta-analysis showed that a 0.001 µg/mL increase in serum or plasma PFOA was associated with a -18.9 g (95% CI -29.8, -7.9) difference in birth weight.

Preeclampsia is a condition that causes the pregnant female to be hypertensive because of reduced renal excretion associated with a decrease in GFR. Preeclampsia is often accompanied by low birth weight (Whitney et al. 1987). Morken et al. (2014) used a subset of the Norwegian Mother and Child Cohort to evaluate the relationship between GFR and fetal size. Participants included 470 preeclamptic patients and 483 nonpreeclamptic females; plasma creatinine measured during the second trimester was used to estimate GFR. For the overall cohort, for each mL/min increase in GFR, infant weight at birth increased 0.73–0.83 g, depending on the method used to calculate GFR. The increases were greater and statistically significant in females with preeclampsia. Differences were not statistically significant for the nonpreeclamptic group. Morken et al. (2014) was not a study of perfluorochemicals and there were no serum measurements of any PFASs. However, because PFOA/PFOS serum levels are expected to be higher with a lower GFR, the finding stimulated examination of the GFR as it relates to serum PFAS levels and the low birth weight identified in the epidemiology studies (Verner et al. 2015; Vesterinen et al. 2014).

The evidence for an inverse association between PFOA levels and birth weight raised the question of whether reverse causality linked to maternal GFR played a role in the association of low birth weight with serum PFOA. PFOA excretion by the kidney is dependent, in part, on the

GFR. Conditions that result in impairment of GFR (and thus increased serum PFOA) also could be related to fetal growth restriction, confounding the association between serum PFOA and decreased birth weight. Vesterinen et al. (2014) examined evidence pertaining to the relationship between fetal growth and maternal GFR using Navigation Guide systematic review methods. They identified 35 relevant studies published between 1954 and 2012 that met the Navigation Guide criteria for inclusion in the analysis. All studies were rated as “low” or “very low” quality due to inconsistency of findings among studies, small sample sizes resulting in large CIs around a mean, and high risk of bias in conduct of the study. The quality rating led to the conclusion that data were “inadequate” to determine an association between fetal growth and GFR. However, a more recent publication described below, expanded the database on the relationship between GFR and fetal size.

Verner et al. (2015) modified the human pregnancy/lactation PK model of PFOA by Loccisano et al. (2013) described in section 2.6.1 to evaluate the association between GFR, serum PFOA levels, and birth weight. When GFR was accounted for in the model simulations, the reduction in birth weight associated with increasing serum PFOA was less than that found by the author’s meta-analysis of the same data. This finding suggests that a portion of the association between prenatal PFOA and birth weight is confounded by maternal GFR differences within the populations studied. The true association for each 1 ng/mL increase in PFOA could be closer to a 7-g reduction (95% CI -8, -6) compared to the 14.72-g reduction (95% CI: -8.92, -1.09) predicted by meta-analysis of the epidemiology data without a correction for low GFR as observed in individuals with pregnancy-induced hypertension or evidence of preeclampsia.

Other pregnancy outcomes. Gestational age and preterm birth and risk of miscarriage were not associated with PFOA in the studies examining pregnancy outcomes in the high-exposure community (Darrow et al. 2014; Nolan et al. 2009, 2010). In contrast, PFOS was positively associated with miscarriage (Darrow et al. 2014).

Congenital anomalies were diagnosed in 1.8%, 1.9%, and 2.0% of the mothers with water provided completely, partially, or not at all by LHWA, respectively (Nolan et al. 2010). When adjusted for confounders, no statistically significant differences were found. Complications with labor and delivery were observed in 32.5%, 35.9%, and 41.9% of the mothers with water provided completely, partially, or not at all by LHWA, respectively. Mothers with water provided by LHWA did have an increased likelihood of having dysfunctional labor, but the number of reported cases was low. Mothers with one or more maternal risk factors were 37.5%, 34.4%, and 39.3% of the populations with water provided completely, partially, or not at all by LHWA, respectively. Adjusted regression models showed no statistical differences across water service status. An increased likelihood of anemia (crude OR 11, 95% CI: 1.8–64) and dysfunctional labor (crude OR 5.3, 95% CI: 1.2–24) in mothers with water provided by LHWA was found, but the number of reported cases was low. No association was found between PFOA and increased incidence of congenital anomalies, other labor and delivery complications, or maternal risk factors.

The C8 Science Panel (2012) concluded that there is no probable link between PFOA and birth defects, miscarriage, preterm birth, or stillbirth. Their conclusion was based on findings in Nolan et al. (2010), Stein et al. (2009), and other data available to the panel. These other data included historical estimates of serum PFOA generated by the panel based on amounts released from the plant and an individual’s residential history.

Fei et al. (2009) examined the association between plasma PFOA concentration and longer time to pregnancy (TTP) as a measure of fecundity in 1,240 females. TTP was categorized as follows: immediate pregnancy (<1 month), 1–2, 3–5, 6–12, and >12 months. Having >12 months TTP or having used fertility treatment to get pregnant were used to define infertility. A total of 620 females had a TTP within the first 2 months of trying to conceive and 379 had a TTP of ≥ 6 months with 188 of those females having a TTP of >12 months. The mean plasma PFOA concentration was 0.0056 $\mu\text{g}/\text{mL}$ for females who planned their pregnancies, and 0.0054, 0.0060, and 0.0063 $\mu\text{g}/\text{mL}$ for TTPs <6 months, 6–12 months, and >12 months, respectively. Plasma PFOA concentration was significantly greater ($p < 0.001$) in females who had TTPs >6 months than those with TTPs <6 months. The females with TTPs >6 months were more likely to be older, have middle socio-occupational status, and have a history of spontaneous miscarriage or irregular menstrual cycles. The adjusted odds for infertility increased 60–154% among females with $>0.00391 \mu\text{g}/\text{mL}$ plasma PFOA concentration compared to females with $<0.00391 \mu\text{g}/\text{mL}$ plasma concentration. The fecundity OR was 0.72, 0.73, and 0.60 for the three highest PFOA concentration quartiles. In the likelihood ratio test, the trend was significant ($p < 0.001$). Both TTP and infertility also were positively associated with serum PFOS levels in this study. Although the results of the study suggest that plasma PFOA concentration could reduce fecundity, the authors noted that selection bias, the unknown quality of the sperm, unknown frequency and timing of intercourse, and abnormal hormone levels might have an impact on the results and fecundity.

Participants enrolled in the Maternal-Infant Research on Environmental Chemicals Study, a Canadian pregnancy and birth cohort, were evaluated for an association between serum PFOA levels (as well as PFOS and PFHxS) and TTP (Vélez et al. 2015). A total of 1,743 females, enrolled between 2008 and 2011 and having a blood sample collected during the first trimester were included. Infertility was defined as having a TTP of >12 months or requiring infertility treatment for the current pregnancy. The geometric mean plasma PFOA level was 0.00166 $\mu\text{g}/\text{mL}$. The crude fecundity OR per one SD increase in log-transformed serum concentration was significantly lower for PFOA (OR=0.91, 95% CI 0.86, 0.96) (and for PFHxS). In fully adjusted models, PFOA (and PFHxS) was associated with an 11% reduction in fecundability per one SD increase in log-transformed serum concentration (OR=0.89; 95% CI 0.83, 0.94). The adjusted odds of infertility increased by 31% per one SD increase of PFOA (OR=1.31; 95% CI 1.11–1.53) (and of PFHxS). No significant associations were observed for PFOS.

Fei et al. (2010b) reported on the effects of PFOA and PFOS on the length of breast-feeding. Self-reported data on the duration of breast-feeding were collected during the telephone interviews with each mother at 6 and 18 months after birth of the child. Higher levels of PFOA were significantly associated with a shorter duration of breast-feeding. In multiparous females, the adjusted OR for weaning before 6 months was 1.23 (95% CI, 1.13–1.33) for each 1-ng/mL increase in PFOA concentration in the maternal blood and the increase was dose-related. A similar association was observed with PFOS levels. No association was found between length of breast-feeding and PFOA levels in females having their first child. The authors speculate that the observed associations might be noncausally related to previous length of breast-feeding or to reduction of PFOA and PFOS through lactation.

Pubertal development. Two studies examined development of puberty in females in relation to prenatal exposure to PFOA as measured through maternal or cord blood samples (Christensen et al. 2011; Kristensen et al. 2013), and another study examined PFOA exposure measured concurrently with the assessment of pubertal status in females and in males (Lopez-Espinosa et al. 2011) (Table 3-11).

Table 3-11. Summary of Epidemiology Studies of PFOA and Pubertal Development

Study	PFOA Level	Results
Prenatal Exposure: General Population		
Christensen et al. 2011 United Kingdom Pregnancy cohort, with case-control of early menarche in follow-up n = 218 cases (menarche before age 11.5 yrs) and 230 controls	0.0036-0.0039 µg/mL (maternal)	Median (75 th percentile) in cases: 3.9 (5.0) controls: 3.6 (4.7) (p = 0.15) OR (95% CI) above versus below median 1.29 (0.86, 1.93) per ln-unit increase in PFOA 1.01 (0.61, 1.68)
Kristensen et al. 2013 Denmark Pregnancy cohort, with follow-up of 343 (79% of eligible) daughters at age 20 Health questionnaire and exams/hormone measurements (for n = 254)	0.0036 µg/mL (maternal)	Difference in age at menarche (months) by exposure group low (0.001–0.003 µg/mL) 0.0 (referent) medium (0.003–0.0043 µg/mL) 0.9 (-3.0, 4.8) high (0.0044–0.0198 µg/mL) 5.3 (1.3, 9.3) continuous 1.01 (0.22, 1.89)
Peripubertal Exposure: High-Exposure Community		
Lopez-Espinosa et al. 2011 United States (C8 Health Project) n = 2,931 girl and 3,076 boy, aged 8-18 yrs Self-reported menarche (girls) and free or total testosterone (boys)	Median 0.058 µg/mL	Prevalence of menarche in girls OR 95% CI days delay Q1: 1.0 (referent) Q2: 1.01 (0.65-1.58) -4 Q3: 1.00 (0.64-1.58) -1 Q4: 0.75 (0.49-1.15) 69 Prevalence of delayed puberty in boys OR 95% CI days delay Q1: 1.0 (referent) Q2: 0.54 (0.35-0.84) 142 Q3: 0.50 (0.32-0.87) 163 Q4: 0.57 (0.37-0.89) 130 Results were broadly similar when the analysis was based on estradiol levels to define menarche or when the models included PFOA and PFOS jointly, though significance was reduced in some comparisons.

Christensen et al. (2011) used data from a prospective cohort study in the United Kingdom to perform a nested case-control study examining the association between age at menarche and gestational exposure to perfluorinated chemicals, including PFOA and PFOS. The study population from the Avon Longitudinal Study of Parents and Children included single-birth female subjects who had completed at least two puberty staging questionnaires between the ages of 8 and 13 years and whose mothers provided at least one analyzable prenatal serum sample. If more than one serum sample was available, the earliest sample provided was used for analysis. The study does not provide information as to when samples were collected. The females were divided into two groups: those who experienced menarche prior to age 11.5 years (n = 218) and a random sample of those who experienced menarche after age 11.5 (n = 230). Confounders such as the mother’s prepregnancy BMI, age at delivery, age at menarche, educational level, and the child’s birth order and ethnic background were included in linear and logistic regression models used to analyze the data. The median maternal serum PFOA concentrations were 0.0039 and 0.0036 µg/mL for the early menarche and nonearly menarche groups, respectively. The authors noted a modest nonsignificant association between the odds of earlier menarche and prenatal serum PFOA concentrations above the median. For all models, the CIs included the null value of 1.0. Similar results were obtained for PFOS.

Effects of prenatal exposure to PFOA (and PFOS) on female and male reproductive function was evaluated in 343 females and 169 males whose mothers participated in a cohort in 1988–1989 (Kristensen et al. 2013; Vested et al. 2013). Maternal blood samples were collected during week 30 of gestation. Follow-up was initiated in 2008 when the offspring were ~20 years old. Median serum PFOA level was 0.0036 µg/mL for the mothers with daughters evaluated. In adjusted regression analysis, daughters from mothers in the highest PFOA tertile had a 5.3-month later age at menarche (95% CI 1.3, 9.3) than those in the lowest tertile. No association was found between prenatal exposure to PFOS and age of menarche. No statistically significant relationships were found between PFOA (or PFOS) exposure and cycle length, reproductive hormone levels, or number of follicles assessed by ultrasound (Kristensen et al. 2013).

Lopez-Espinosa et al. (2011) examined the association of serum PFOA concentration and the age of puberty in exposed children of the Mid-Ohio Valley. Data from the C8 Health project (e.g., sex steroid hormone levels, self-reported menarche status) along with detailed date of birth information were used to determine age of puberty in males (n = 3,076) and females (n = 2,931) aged 8–18 years. Serum PFOA concentrations were divided into quartiles: <0.0114, 0.0114–0.023, >0.023–0.058, and >0.058 µg/mL. Confounders such as age at survey, BMI, BMI z-score, height, family income, ethnicity, smoking status, alcohol consumption, and date and time of sample collection were included in the logistic regression models used to analyze the data. The median PFOA concentrations were 0.026 and 0.020 µg/mL in males and females, respectively. No association between PFOA concentration and puberty was observed for males. Reduced odds of having reached puberty was associated with higher PFOA exposure in females (OR=0.57, 95% CI 0.37–0.89). There were 130 days of delay between the highest and lowest quartile. Reduced odds of experiencing menarche at a younger age (10–15 years) also was observed (OR 0.83, 95% CI 0.74–0.93). The results suggested that PFOA was associated with a later age of menarche. PFOS was associated with delayed puberty in both males and females. The authors expressed caution in interpretation of the data because of lack of serum PFOA concentration prior to puberty, PFOA concentration having been measured after the attainment of puberty, and lack of secondary sexual maturation data (i.e., physical, Tanner criteria, and biomarker measurements).

Male reproductive effects. Joensen et al. (2009) examined the association between PFASs, including PFOA, and testicular function in 105 Danish males who provided semen and blood samples as part of reporting for the military draft in 2003. The males chosen for the study had the highest testosterone concentrations (ranging from 30.1 to 34.8 nmol/L; n = 53; 18.2–24.6 years) and lowest testosterone concentrations (ranging from 10.5 to 15.5 nmol/L; n = 52; 18.2–25.2 years). Regression models were used to analyze associations between PFOA and testicular function. Median serum PFOA concentration was 0.0044, 0.0050, and 0.0049 µg/mL in the high testosterone, low testosterone, and combined groups, respectively. A nonsignificant negative association was observed between serum PFOA concentration and semen volume, sperm concentration, sperm count, sperm motility, or sperm morphology. No association was observed between serum PFOA concentration and testosterone, estradiol, sex hormone-binding globulin (SHBG), luteinizing hormone (LH), follicle-stimulating hormone (FSH), and inhibin B. However, significantly fewer (p<0.05) morphologically normal sperm were seen in males with high combined levels of PFOA/PFOS (6.2 million spermatozoa) than in males with low PFOA/PFOS levels (15.5 million spermatozoa).

In a slightly expanded study, Joensen et al. (2013) investigated the associations between PFASs, including serum PFOA concentration, and reproductive hormones and semen quality in

247 healthy young Danish males (mean age 19.6 years). Serum samples were analyzed for PFOA as well as total testosterone (T), estradiol, SHBG, LH, FSH, and inhibin-B. The mean PFOA level was 0.0035 µg/mL. No associations were found between PFOA levels (or 12 other PFAS) and any hormone level or semen quality parameters. PFOS levels were negatively associated with testosterone.

An association between serum levels of seven PFASs and 35 semen quality parameters was evaluated in 462 males enrolled in the LIFE study cohort (Buck Louis et al. 2015). The males were from Michigan and Texas with a mean age of 31.8 years and mean PFOA levels 0.00429–0.00509 µg/mL. PFOA was significantly associated with a lower percentage of sperm with coiled tails, an increased curvilinear velocity, and a slightly larger acrosome area of the head. In total, six PFASs (including PFOA) were associated with changes in 17 semen quality endpoints.

Effects of prenatal exposure to PFOA (and PFOS on male reproductive function was evaluated in 169 males whose mothers participated in a cohort in 1988–1989 (Vested et al. 2013). Maternal blood samples were collected during week 30 of gestation. Follow-up was initiated in 2008 when the offspring were ~20 years old. Median serum PFOA level was 0.0038 µg/mL for mothers with sons evaluated. Multivariable regression models showed significant negative trends for sperm concentration and total sperm count in association with *in utero* exposure to PFOA. A 34% reduction in sperm concentration (95% CI 58, 5%) and a 34% reduction in total count (95% CI 62, 12%) were estimated for the highest exposure tertile compared with the lowest tertile. Maternal PFOA level also was positively associated with higher FSH and LH levels in the sons. No associations were found between PFOA level and percentage of progressive sperm, sperm morphology, semen volume, or testicular volume. PFOS was not associated with any outcome (Vested et al. 2013).

3.1.1.9 Steroid Hormones

Occupational exposure studies. Olsen et al. (1998) examined several hormones, including cortisol, estradiol, FSH, dehydroepiandrosterone sulfate, 17 gamma-hydroxyprogesterone (a testosterone precursor), free testosterone, T, LH, prolactin, and SHBG in male workers at the Cottage Grove, Minnesota, production plant for 1993 and 1995. This was the same population used for the thyroid hormone study described above for 111 workers in 1993 and 80 in 1995. Employees were placed into four exposure categories based on their serum PFOA levels: 0–1 µg/mL, 1– < 10 µg/mL, 10– < 30 µg/mL, and >30 µg/mL. Statistical methods used to compare PFOA levels and hormone values included multivariable regression analysis, ANOVA, and Pearson correlation coefficients. No association between serum PFOA and any hormone was observed, but some trends were observed. When the mean measures of the various hormones were compared by exposure categories, there was a statistically significant elevation in prolactin ($p = 0.01$) in 1993 only for the 10 workers whose serum PFOA levels were between 10 and 30 µg/mL compared to the lower two exposure categories.

Estradiol levels in the >30 µg/mL PFOA group in both years were 10% higher than in the other PFOA groups, but the difference was not statistically significant. These results were confounded by estradiol being correlated with BMI ($r = 0.41$, $p < 0.001$ in 1993, and $r = 0.30$, $p < 0.01$ in 1995). The authors postulated that the study might not have been sensitive enough to detect an association between PFOA and estradiol because measured serum PFOA levels were likely below the observable effect levels suggested in animal studies (e.g., 55 µg/mL PFOA in the CD rat). Only three employees in this study had PFOA serum levels that high. They also

suggest that the higher estradiol levels in the highest exposure category could suggest a threshold relationship between PFOA and estradiol.

In the Sakr et al. study (2007a) of 1,025 workers at the DuPont Washington Works facility in West Virginia, an association was observed between serum PFOA and serum estradiol ($p = 0.017$) and testosterone ($p = 0.034$) in male workers; however, circadian variations of hormones were not taken into consideration during analysis. The biological significance of the results is unknown.

Costa et al. (2009) found no association between serum PFOA concentration and estradiol or testosterone in 53 male workers at a PFOA production plant in Italy based on medical surveillance data collected between 2000 and 2007.

High-exposure community studies. Knox et al. (2011) examined the endocrine disrupting effects of perfluorocarbons in females from the C8 Health Project by analyzing the relationship between serum PFOA, serum estradiol concentration, and menopause onset. The population included females over age 18 years ($n = 25,957$). Serum PFOA and estradiol concentrations were determined from blood samples. Females who were pregnant; had had full hysterectomies; and were taking any prescription hormones, selective estrogen receptor modulators, and/or fertility agents were excluded from estradiol analysis. Serum PFOA concentrations were grouped into quintiles (natural log-transformation)—Q1 = 0.00025–0.0112; Q2 = 0.0113–0.0198; Q3 = 0.0199–0.0367; Q4 = 0.0368–0.0849; and Q5 = 0.0850–22.412 $\mu\text{g/mL}$. Estradiol analysis was calculated by age group—18–42 years, $>42 \leq 51$ years, and $>51 \leq 65$ years. Menopause was determined by questionnaire. Menopause analysis was calculated by age group—30–42 years, $>42 \leq 51$ years, and $>51 \leq 65$ years—and excluded those who reported having had hysterectomies. Logistic regression models were adjusted for smoking, age, BMI, alcohol consumption, and regular exercise. PFOA concentration in females who had had hysterectomies was significantly higher than in females who had not had hysterectomies. Serum PFOA and estradiol concentrations were not associated, while PFOS levels were negatively associated with estradiol. The odds of attaining menopause analysis in the oldest group of females, showed that all quintiles were significantly higher for all quintiles than the lowest, and in females between the ages of 42 and 51 years, Q3, Q4, and Q5 were significantly higher than the lowest. PFOS also was associated with increased odds of attaining menopause in women 42–51 years and >51 years. Data interpretation was limited by the cross-sectional study design and survey-reported menopause without age or independent confirmation.

3.1.1.10 Neurodevelopment

High-exposure community studies. A subset of 321 children enrolled in the C8 Health Project was assessed for neurobehavioral development 3–4 years after enrollment (Stein et al. 2013). The children had serum samples collected at enrollment in 2005–2006 with the current follow-up evaluation conducted in 2009–2010, when the children were 6–12 years old. Both the mother and teacher completed surveys to elicit information on each child's executive function, attention deficit hyperactivity disorder- (ADHD-) like behavior, and behavioral problems. Information on family demographics and other health conditions of the child were included as confounders. Linear regression was used to determine the association between PFOA levels and mother and teacher reports.

The median PFOA level was 0.0351 µg/mL with an IQR of 0.0158–0.0941 µg/mL. When comparing the highest to the lowest PFOA quartile, survey results from the mother for both executive function and ADHD showed a favorable association for males, but an adverse association for females. These findings were not replicated when males and females were analyzed together or with results from the teacher surveys. No association was found between PFOA levels and either mother or teacher scores for behavioral problems in females and males.

In 2012, the C8 Science Panel concluded that there is no probable link between PFOA exposure and neurodevelopmental disorders in children, including attention deficit disorders and learning disabilities. Their conclusion was based on epidemiology studies conducted by the panel and other data available.

General population studies. Fei et al. (2008b) examined the association between plasma PFOA concentration in pregnant females and motor and mental developmental milestones of their children. The mothers self-reported the infant's fine and gross motor skills and mental development at 6 and 18 months of age. There was no association between maternal plasma PFOA concentration and Apgar score or between maternal plasma PFOA concentration and fine motor skills, gross motor skills, or cognitive skills at 6 and 18 months of age. The children born to females having higher plasma PFOA concentrations reached developmental milestones at the same times as children born to females having lower plasma PFOA concentrations. The authors concluded that there was no association between maternal early pregnancy levels of PFOA and motor or mental developmental milestones in offspring. However, in children at 18 months, mothers with higher PFOS levels were slightly more likely to report that their babies started sitting without support at a later age.

A subset of the Danish National Birth Cohort was evaluated for an association between prenatal PFAS exposure and the risk of cerebral palsy (Liew et al. 2014). A total of 156 cases of cerebral palsy were identified and matched to 550 randomly selected controls. Stored maternal plasma samples were analyzed for 16 PFAS and six compounds were quantifiable in >90% of the samples. For the cerebral palsy cases and matched controls, median maternal PFOA levels were 0.00456 and 0.00400 µg/mL, respectively, for males and 0.00390 and 0.00404 µg/mL, respectively, for females. Per natural-log unit increase in maternal PFOA level, the risk of developing cerebral palsy in males was significantly increased (RR=2.1; 95% CI 1.2, 3.6). Positive associations were also found with PFOS and perfluoroheptane sulfonate. No association was found between any PFAS level and risk of cerebral palsy in females.

Fei and Olsen (2011) examined the association between prenatal PFOA (and PFOS) exposure and behavior or coordination problems in children at age 7. The children and their mothers were part of the Danish National Birth Cohort. Behavioral problems were assessed using the Strengths and Difficulties Questionnaire (SDQ), and coordination problems were assessed using the Developmental Coordination Disorder Questionnaire (DCDQ) completed by the mothers. A total of 787 mothers completed the SDQ and 537 completed the DCDQ for children aged 7.01–8.47 years (mean age 7.15 years). The mean maternal PFOA concentration was 0.0057 µg/mL, and PFOA levels were divided into quartiles: <LLOQ–0.00395, 0.00396–0.00532, 0.00535–0.00711, and 0.00714–0.02190 µg/mL. A child having higher scores in total difficulties, emotional symptoms, and hyperactivity was negatively associated with the second or third PFOA quartiles (OR=0.56, 95% CI 0.27–1.19; p<0.05 and OR=0.36, 95% CI 0.15–0.82; p<0.05, respectively) when compared with females in the lowest quartile. ORs adjusted for parity, maternal age, prepregnancy BMI, pregnancy smoking and alcohol consumption, socio-occupational status, child gender, breast-feeding, birth year, home density, gestational age at blood draw, and

parental behavior problem as children did not show a positive association between prenatal PFOA exposure and behavior or coordination problems. Overall, no significant association between behavioral or coordination problems in children 7 years of age and prenatal PFOA (and PFOS) exposure was found.

Similar to the above study, the association between maternal PFOA (and PFOS) levels and offspring behavior and motor development was investigated in a subset of the Biopersistent Organochlorines in Diet and Human Fertility study (INUENDO) birth cohort (Høyer et al. 2015a). Pregnant females were enrolled between May 2002 and February 2004 with a total of 1,106 mother-child pairs at follow-up between January 2010 and May 2012, when the children were 7–9 years old. The study population consisted of 526 pairs from Greenland, 89 pairs from Poland, and 491 pairs from Ukraine. Maternal blood samples for measurement of plasma PFOA levels were taken any time during pregnancy. Behavior of children was assessed with SDQ score, and logistic regression models were used in the analyses of PFOA tertile levels and behavioral problems. Motor development was assessed with DCDQ score, and linear regression was used for analyses. All analyses were performed on the entire cohort as well as by country, except that not all analyses could be performed on the Polish subset because of the small number of cases. The median maternal plasma PFOA level was 0.0014 µg/mL for the combined population and 0.0018, 0.001, and 0.0027 µg/mL for the pregnant females from Greenland, Ukraine, and Poland, respectively.

No associations were found between PFOA (and PFOS) levels and motor development score. Total SDQ score was not associated with PFOA levels; however, the OR of having an abnormal total SDQ score was 2.7 (95% CI 1.2, 6.3) for all groups combined. PFOS levels were associated with higher total SDQ score only in Greenland. The highest PFOA tertile was associated with a 0.5-point higher hyperactivity score in both the combined analysis and in Greenland, but no associations were found in Poland and Ukraine. The OR for hyperactive behavior in the combined analysis was 3.1 (95% CI 1.3, 7.2) for the highest tertile compared to the lowest PFOA tertile. In Greenland, the ORs for hyperactivity were increased for the middle (OR=5.4, 95% CI 1.1, 25.6) and highest (OR=6.3, 95% CI 1.3, 30.1) tertiles (Høyer et al. 2015a).

Hoffman et al. (2010) examined the associations between perfluorochemicals, including PFOA, and diagnosis of ADHD using the NHANES data from 1999–2000 and 2003–2004. The study population comprised 571 children aged 12–15 years, including those who had been diagnosed as having ADHD (n = 48) and/or were taking ADHD medications (n = 21). Age, gender, and race/ethnicity were included as covariates; and socioeconomic status, health insurance coverage and having a routine health care provider, living with someone who smokes, birth weight, admittance to a neonatal intensive care unit, maternal smoking, and preschool attendance were confounders. Regression models were used to analyze the data. The median serum PFOA level was 0.0044 µg/mL and ranged from 0.0004 to 0.0217 µg/mL. Serum PFOA was positively associated with parental report of ADHD (OR=1.12, 95% CI 1.01–1.23). The OR for serum PFOA and parental report of ADHD and ADHD medication use was 1.19 (95% CI 0.95–1.49). Both PFOS and perfluorohexane sulfonate also were positively associated with parentally reported ADHD. Data interpretation was limited by the cross-sectional study design, random misclassification error resulting from using current PFOA levels as proxy measures of etiologically relevant exposures, and other confounders not included in the available data.

3.1.1.11 Postnatal Development

General population studies. Andersen et al. (2010) examined the association between maternal plasma PFOA concentration and offspring weight, length, and BMI at 5 and 12 months of age. The mothers (n = 1,010) reported the information during an interview, and weight and length measurements were used to calculate BMI. The median PFOA level was 0.0052 µg/mL with a range of 0.0005–0.0219 µg/mL. Maternal plasma PFOA concentration was inversely associated with weight at 5 months (β -30.2, 95% CI -59.3–1.1), BMI at 5 months (β -0.067, 95% CI -0.129–0.004), weight at 12 months (β -43.1, 95% CI -82.9–3.3), and BMI at 12 months in male children (β -0.078, 95% CI -0.144–0.011) in models adjusted for maternal age, parity, prepregnancy BMI, smoking, gestational age at blood draw, socioeconomic status, and breastfeeding. Similar inverse associations were found with PFOS. No associations were observed between maternal plasma PFOA concentration and the endpoints for female children in the adjusted models.

The latest report on the Danish National Birth Cohort evaluated an association between maternal plasma PFOA levels and the children's BMI, waist circumference, and risk of being overweight at 7 years of age (Andersen et al. 2013). From the subset of 1,400 females who provided blood samples during their first trimester, children were included if they had weight and height information (n = 811) or waist measurements (n = 804) at age 7 years. The median PFOA level was 0.0053 µg/mL with a range of 0.0005–0.0219 µg/mL. Maternal PFOA levels were inversely associated with all of the children's anthropomorphic endpoints, but statistical significance was not attained and a dose response was not observed. Maternal PFOA (or PFOS) did not affect the risk of being overweight in either males or females.

The association between maternal PFOA (and PFOS) levels and prevalence of offspring that are overweight plus waist-to-height ratio >0.5 was investigated in a subset of the INUENDO birth cohort (Høyer et al. 2015b). Pregnant females were enrolled between May 2002 and February 2004 with a total of 1,022 mother-child pairs at follow-up between January 2010 and May 2012, when the children were 7–9 years old. The study population consisted of 531 pairs from Greenland and 491 pairs from Ukraine. Maternal blood samples for measurement of plasma PFOA levels were taken at a mean gestational age of 24 weeks. Each child's weight and height were measured and BMI calculated. All analyses were performed on the entire cohort as well as by country.

The median maternal plasma PFOA level was 0.0018 µg/mL in pregnant females from Greenland and 0.0010 µg/mL in pregnant females from Ukraine. No associations were found between PFOA (and PFOS) levels and risk of being overweight in the combined analysis or in Ukraine. In Greenland, the risk of being overweight was slightly increased only for females (RR=1.81, 95% CI 1.04, 3.17). PFOA association with risk of having waist-to-height ratio >0.5 was slightly increased for the combined analysis (RR=1.30, 95% CI 0.97, 1.74), but statistical significance was not attained. PFOS levels were significantly associated with waist-to-height ratio >0.5 in the combined analysis (Høyer et al. 2015b).

Halldorsson et al. (2012) examined prenatal exposure to PFASs, including PFOA, and the risk of being overweight at 20 years of age in a prospective study. A birth cohort consisting of 665 mother-offspring pairs was recruited from a midwife center in Aarhus, Denmark. Maternal PFOA levels were measured in serum samples collected during week 30 of gestation for assessment of *in utero* PFOA exposure and offspring anthropometry at 20 years. The median PFOA concentration was 0.0037 ± 0.0020 µg/mL with quartiles of 0.0024 ± 0.0006 , $0.0033 \pm$

0.0004, 0.0042 ± 0.0005 , and 0.0058 ± 0.0019 $\mu\text{g/mL}$. Three PFASs, including PFOS, perfluorooctane sulphonamide, and perfluorononanoate, increased across quartiles of PFOA concentration, but eight other PFASs did not. In covariate-adjusted analyses, female offspring whose mothers were in the highest quartile had 1.6 kg/m^2 higher BMI (95% CI: 0.6, 2.6) and 4.3 cm larger waist circumference (95% CI: 1.4, 7.3) than offspring whose mothers were in the lowest quartile. Female offspring of mothers in the highest versus lowest PFOA quartile were also more likely to be overweight [RR 3.1 (95% CI: 1.4, 6.9)] and to have a waist circumference >88 cm at 20 years of age [3.0 (95% CI: 1.3, 6.8)]. Among female participants who provided blood samples at clinical examination ($n = 252$), maternal PFOA concentration was positively associated with insulin, leptin, and the leptin-adiponectin ratio; and inversely associated with adiponectin levels. PFOA was not associated with being overweight or obesity in male offspring. The other PFASs were not significantly associated with any endpoint after adjustment for PFOA.

Geiger et al. (2014b) used data from the NHANES to determine whether there was a relationship between serum PFOA levels and hypertension in children. A total of 1,655 participants (aged 12–18 years) from the 1999–2000 and 2003–2008 cycles of the survey who had PFOA measurements available were examined. Blood pressure was measured to determine the presence of hypertension, and linear regression modeling was used to study the association between increasing quartiles of serum PFOA and mean changes in systolic and diastolic blood pressures. Mean PFOA level was 0.0044 ± 0.0001 $\mu\text{g/mL}$. No association was found between serum PFOA (or PFOS) levels and hypertension in either unadjusted or multivariable-adjusted analyses. Compared with the lowest quartile, the multivariable-adjusted OR (95% CI) of hypertension in the highest quartile of exposure was 0.69 (0.41–1.17) (P -trend >0.30).

3.1.1.12 Summary and Conclusions from the Human Epidemiology Studies

Numerous epidemiology studies have been conducted of workers, a large highly exposed community (the C8 Health Project), and the general population to evaluate the association of PFOA exposure to a variety of health endpoints. Health outcomes assessed include blood lipid and clinical chemistry profiles, thyroid effects, diabetes, immune function, birth and fetal and developmental growth measures, and cancer.

Serum lipids. The association between PFOA and serum lipids has been examined in several studies in different populations. Cross-sectional and longitudinal studies in occupational settings (Costa et al. 2009; Olsen et al. 2000, 2003; Olsen and Zobel 2007; Sakr et al. 2007a, 2007b; Steenland et al. 2015) and in the high-exposure community (the C8 Health Project study population) (Fitz-Simon et al. 2013; Frisbee et al. 2010; Steenland et al. 2009; Winquist and Steenland 2014a) generally observed positive associations between serum PFOA and TC in adults and children (aged 1– <18 yrs); most of these effect estimates were statistically significant. Although exceptions to this pattern are present (e.g., some of the analyses examining incidence of self-reported high cholesterol based on medication use [Steenland et al. 2015; Winquist and Steenland 2014a]), the results are relatively consistent and robust. Similar associations were seen in analyses of LDL, but were not seen with HDL. The range of exposure in occupational studies is large (with means varying between 0.4 and >12 $\mu\text{g/mL}$), and the mean serum levels in the C8 population studies were around 0.08 $\mu\text{g/mL}$. Positive associations between serum PFOA and TC (i.e., increasing lipid level with increasing PFOA) were observed in most of the general population studies at mean exposure levels of 0.002–0.007 $\mu\text{g/mL}$ (Eriksen et al. 2013; Fisher et al. 2013; Geiger et al. 2014a; Nelson et al. 2010; Starling et al. 2014). The interpretation of results for these general population studies is limited, however, by the moderately strong correlations (Spearman $r > 0.6$) and similarity in results seen for PFOS and

PFOA. Additionally, many of the C8 studies do not appear to have controlled for the impact of diet on serum lipids.

Liver disease and liver function. Few studies of the relationship between PFOA and liver disease are available, but the C8 Health Project did not observe associations with hepatitis, fatty liver disease, or other types of liver disease. In the studies of PFOA exposure and liver enzymes (measured in serum), positive associations were seen. The results of the occupational studies provide evidence of an association with increases in serum AST, ALT, and GGT, with the most consistent results seen for ALT. The associations were not large and might depend on the covariates in the models, including BMI, use of lipid lowering medications, and triglycerides (Costa et al. 2009; Olsen et al. 2000, 2003; Olsen and Zobel 2007; Sakr et al. 2007a, 2007b). Two population-based studies of highly exposed residents in contaminated regions near a fluorochemical industry in West Virginia have evaluated associations with liver enzymes, and the larger of the two studies reported associations of increasing serum ln ALT and ln GGT levels with increasing serum PFOA concentrations (Emmett et al. 2006; Gallo et al. 2012). A cross-sectional analysis of data from the NHANES, representative of the U.S. national population, also found associations with ln PFOA concentration with increasing serum ALT and ln GGT levels. Serum bilirubin was inversely associated with serum PFOA in the occupational studies. A U-shaped exposure-response pattern for serum bilirubin was observed among the participants in the C8 Health Project, which might explain the inverse associations reported for occupational cohorts. Overall, an association of serum PFOA concentration with elevations in serum levels of ALT and GGT has been consistently observed in occupational, highly exposed residential communities, and the U.S. general population. The associations are not large in magnitude, but indicate the potential of PFOA to affect liver function.

Immune function. Associations between prenatal, childhood, or adult PFOA exposure and risk of infectious diseases (as a marker of immune suppression) have not been consistently seen, although there was some indication of effect modification by gender (i.e., associations seen in female children but not in male children) (Fei et al. 2010a; Granum et al. 2013; Looker et al. 2014; Okada et al. 2012). Three studies have examined associations between maternal and/or child serum PFOA levels and vaccine response (measured by antibody levels) in children (Grandjean et al. 2012; Granum et al. 2013) and in adults (Looker et al. 2014). The study in adults was part of the high-exposure community C8 Health Project. A reduced antibody response to one of the three influenza strains tested after subjects received the flu vaccine was seen with increasing levels of serum PFOA; these results were not seen with PFOS. The studies in children were conducted in general populations in Norway and in the Faroe Islands. Decreased vaccine response in relation to PFOA levels was seen in these studies, but similar results also were seen with correlated PFASs (e.g., PFOS).

Thyroid. Three large studies provide support for an association between PFOA exposure and incidence or prevalence of thyroid disease in women or children, but not in men (Lopez-Espinosa et al. 2012; Melzer et al. 2010; Winquist and Steenland 2014b). In addition, associations between PFOA and TSH were seen in pregnant females with anti-TPO antibodies (Webster et al 2014). In contrast, generally null associations were found between PFOA and TSH in people who had not been diagnosed with thyroid disease.

Diabetes. No associations were observed between serum PFOA levels and type II diabetes incidence rate in general or worker populations with mean serum PFOA up to 0.0913–0.113 µg/mL (MacNeil et al. 2009; Steenland et al. 2015). PFOA was not associated with measures of metabolic syndrome in adolescents or adults (Lin et al. 2009). However, one study found an

increased risk for developing gestational diabetes in females with mean serum PFOA (measured preconception) of 0.00394 µg/mL (Zhang et al. 2015).

Fertility, pregnancy, and birth outcomes. There are no occupational exposure or general population studies examining pregnancy-related hypertension and preeclampsia in relation to PFOA exposure. The only data available come from the high-exposure C8 Health Project study population. Several studies, using different designs and exposure measures, have examined that outcome in this population (Darrow et al. 2013; Savitz et al. 2012a, 2012b; Stein et al. 2009). There is a progressively greater refinement and reduction in misclassification (or exposure and outcome) among this set of studies. Each of the studies provides some evidence of an association between PFOA exposure and risk of pregnancy-induced hypertension or preeclampsia, with the most robust findings from the methodologically strongest study (Darrow et al. 2013).

The association between PFOA and birth weight was examined in numerous studies. Most studies measured PFOA using maternal blood samples taken in the second or third trimester or in cord blood samples. Studies on the high-exposure C8 community population did not observe associations between PFOA and either birth weight among term births or the risk of low birth weight among all (singleton) births (Darrow et al. 2013; Nolan et al. 2009; Savitz et al. 2012a, 2012b; Stein et al. 2009). In contrast, several analyses of general populations indicate a negative association between PFOA levels and birth weight (Apelberg et al. 2007; Fei et al. 2007; Maisonet et al. 2012), while others did not attain statistical significance (Chen et al. 2012; Hamm et al. 2010; Monroy et al. 2008; Washino et al. 2009). A meta-analysis of many of these studies found a mean birth weight reduction of 19 g (95% CI: -30, -9) per each one unit (ng/mL) increase in maternal or cord serum PFOA levels (Johnson et al. 2014). It has been suggested that GFR can impact birth weight (Morken et al. 2014). Verner et al (2015) conducted a meta-analysis based on PBPK simulations and found that some of the association reported between PFOA and birth weight is attributable to GFR and that the actual association could be closer to a 7-g reduction (95% CI: -8, -6). Verner et al. (2015) showed that, in individuals with low GFR, there are increased levels of serum PFOA and lower birth weights. While there is some uncertainty in the interpretation of the observed association between PFOA and birth weight given the potential impact of low GFR, the available information indicates that the association between PFOA exposure and birth weight for the general population cannot be ruled out. In humans with low GFR (which includes females with pregnancy-induced hypertension or preeclampsia), the impact on body weight is likely due to a combination of the low GFR and the serum PFOA.

Two studies examined development of puberty in females in relation to prenatal exposure to PFOA as measured through maternal or cord blood samples in follow-up of pregnancy cohorts conducted in England (Christensen et al. 2011) and in Denmark (Kristensen et al. 2013). The results of these two studies are conflicting, with no association (or possible indication of an earlier menarche seen with higher PFOA) in Christensen et al. (2011), and a later menarche seen with higher PFOA in Kristensen et al. (2013). Another study examined PFOA exposure measured concurrently with the assessment of pubertal status (Lopez-Espinosa et al. 2011). An association between later age at menarche and higher PFOA levels was observed, but the interpretation of this finding is complicated by the potential effect of puberty on the exposure biomarker levels (i.e., reverse causality).

Studies found a positive association with ADHD in children in the highly exposed community (Stein et al. 2013) and the general population (Hoffman et al. 2010). No other behavior endpoints in children were associated with maternal PFOA levels in either population.

Limited data suggest a correlation between higher PFOA levels (>0.02 $\mu\text{g}/\text{mL}$) in females and decreases in fecundity and fertility (Fei et al. 2009; Vélez et al. 2015), but there are no clear effects of PFOA on male fertility endpoints (0.0035 – 0.005 $\mu\text{g}/\text{mL}$) (Joensen et al. 2009, 2013).

C8 Science Panel conclusions. As part of the C8 Health Project, the C8 Science Panel used epidemiological and other data available to them to assess probable links between PFOA exposure and disease (C8 Science Panel 2012). Analyses conducted by the C8 Science Panel used historical serum PFOA estimates over time, which were developed based on estimated intake of contaminated drinking water. The panel concluded that a probable link existed between PFOA exposure and ulcerative colitis, high cholesterol, pregnancy-induced hypertension, and thyroid disease.

The C8 Science Panel found no probable link between PFOA exposure and multiple other conditions, including birth defects, other autoimmune diseases (e.g., rheumatoid arthritis, lupus, type I diabetes, Crohn's disease, MS), type II diabetes, high blood pressure, coronary artery disease, infectious disease, liver disease, Parkinson's disease, osteoarthritis, neurodevelopmental disorders in children (e.g., ADHD, learning disabilities), miscarriage or stillbirth, chronic kidney disease, stroke, asthma or COPD, and preterm birth or low birth weight (C8 Science Panel 2012).

3.1.2 Cancer

Occupational exposure studies. Several occupational studies examining cancer mortality have been conducted at 3M's Cottage Grove facility in Minnesota and at the DuPont Washington Water Works plant in West Virginia. These studies have focused on kidney, bladder, liver, pancreatic, testicular, prostate, thyroid, and breast cancers. For cancers with a high survival rate (i.e., bladder, kidney, prostate, testicular, thyroid, and breast cancer), studies that use mortality data provide a more limited basis for drawing conclusions than studies that use incidence data. The discussion in this section summarizes the design and results of the available studies, focusing on the most recent update of occupational cohorts. Table 3-12 presents results for studies of kidney and testicular cancer.

Raleigh et al. (2014) is the latest update of the analyses of mortality in the 3M Cottage Grove workers, previously analyzed in Lundin et al. (2009) and Gilliland and Mandel (1993). Raleigh et al. (2014) followed 4,668 Cottage Grove workers through 2008, using an improved exposure reconstruction method and adding a nonexposed worker referent group from a different 3M plant. In addition to the mortality data, incidence data based on state cancer registries also were included. Exposure estimates for inhalation exposures were calculated from work history records and industrial hygiene monitoring data; blood levels were not included. No associations were found between PFOA exposure and the risk of dying from any cancer type (see Table 3-12 for bladder, kidney, and testicular cancer results). The mean age of the workers was 29 years at the start of employment and 63 years at the end of follow-up.

Table 3-12. Summary of PFOA Epidemiology Studies of Kidney and Testicular Cancer

Reference and Study Details	Analysis Group	Kidney	Testicular
Occupational Settings			
Raleigh et al. 2014 3M, Minnesota n = 4,668, follow-up through 2008 Mean age: 29 yrs at start of employment Mortality and incidence Comparison based on another (non-PFOA) 3M plant in Minnesota (n = 4,359) Cumulative exposure level based on industrial hygiene data (air monitoring), and PFOA production levels [update of Gilliland and Mandel 1993 and Lundin et al. 2009]	All (Minnesota referent) By quartile, mortality analysis 1 up to 0.000026 µg/m3-yr 2 up to 0.00014 3 up to 0.00073 4 maximum not reported By quartile, incidence analysis 1 up to 0.000029 µg/m3-yr 2 up to 0.00015 3 up to 0.00079 4 maximum not reported	0.53 (0.20, 1.16) (n = 6) Mortality 0.32 (0.01, 1.77) (n = 1) 0.74 (0.09, 2.69) (n = 2) 1.66 (0.08, 2.38) (n = 2) 0.42 (0.01, 2.34) (n = 1) Incidence 1.07 (0.36, 3.16) (n = 4) 1.07 (0.36, 3.17) (n = 4) 0.98 (0.33, 2.92) (n = 4) 0.73 (0.21, 2.48) (n = 4)	n = 5 incident cases reported; no further analysis done
Steenland and Woskie 2012 DuPont Washington Water Works, West Virginia n = 5,791, follow-up through 2007 Mortality [update of Leonard et al. 2008, which did not include analysis by cumulative exposure] [Steenland and Woskie 2012 examined incidence of bladder, colorectal, and prostate cancers, and of melanoma]	DuPont referent (plants from 8 surrounding states) U.S. referent Cumulative exposure (ppm-yr) 0 - < 904 904 - < 1,520 15,20 - < 2,720 ≥ 2720	1.28 (0.66, 2.24) (n = 12) 1.09 (0.56, 1.90) (n = 12) 1.07 (0.02, 3.62) (n = 1) 1.37 (0.28, 3.99) (n = 3) -- (0.0, 1.42) (n = 0) 2.66 (1.15, 5.24) (n = 8)	1.80 (0.05, 10.03) (n = 1)
High-Exposure Community			
Vieira et al. 2013 C8 Health Project population (Ohio and West Virginia) Incidence Modeled estimates for 1951–2008 using residence at time of diagnosis and emissions data and environmental characteristics	Total for 6 water districts (median serum level ranged from 5 to 125 µg/l) Annual serum levels (µg/l); assumed 10-year residence and 10-year latency (Ohio) Unexposed Low: 3.7 - 12. Medium: 12.9 - 30.7 High: 30.8 - 109 Very high: > 100	1.1 (0.9, 1.4) (n = 94) 1.0 (referent) 0.8 (0.4, 1.5) (n = 11) 1.2 (0.7, 2.0) (n = 17) 2.0 (1.3, 3.2) (n = 22) 2.0 (1.0, 3.9) (n = 9)	(0.6, 1.8) (n = 18) (referent) 0.2 (0.0, 1.6) (n = 1) 0.6 (0.2, 2.2) (n = 3) 0.3 (0.0, 2.7) (n = 1) 2.8 (0.8, 9.2) (n = 6)
Barry et al. 2013 C8 Health Project population (Ohio and West Virginia) Case-control (n varies by cancer) Incidence Modeled estimates for 1951–2008 using individual-level data on residential history, drinking water source, tap water consumption, emissions data, environmental characteristics, water pipe installation, PK data, and workplace water consumption (and for workers, workplace exposure based on job exposure matrix and modeling using serum samples from 1979–2004 and job history data.	Full sample Cumulative exposure, quartiles (cutpoints based on cancer-specific case distribution; approximate midpoints) 1 (30-50 µg/mL-yr) 2 (90-200 µg/mL-yr) 3 (800-1400 µg/mL-yr) 4 (100,000 µg/mL-yr)	1.09 (0.97, 1.21) (n = 105) (referent) 0.99 (0.53, 1.85) 1.69 (0.3, 3.07) 1.43 (0.76, 2.69) trend p = 0.34 community cohort; HR = 1.0, 0.94, 1.08, 1.50, trend p = 0.02; worker cohort HR = 1.0, 1.22, 3.27, 0.99, trend p = 0.42	1.28 (0.95, 1.73) (n = 17) 1.0 (referent) 0.87 (0.15, 4.88) 1.08 (0.20, 5.90) 2.36 (0.41, 13.7) trend p = 0.02 15 of the cases from the community sample; HR = 1.0, 0.98, 1.54, 4.66, trend p = 0.02

Steenland and Woskie (2012) updated the cohort study by Leonard et al. (2008) of employees at the DuPont Washington Works plant in West Virginia (see Table 3-12 for bladder, kidney, and testicular cancer results). This study included 5,791 individuals who had worked at the DuPont West Virginia plant for at least 1 year between 1948 and 2002. Mean duration of employment was 19 years. Deaths through 2008 were ascertained through either the National Death Index or death certificate data. Exposure quartiles were assessed by estimated cumulative annual serum levels based on blood samples from 1,308 workers taken during 1979–2004 and time spent in various job categories (ppm-years). Referent groups included both nonexposed DuPont workers in the same region and the U.S. population. Overall, the mean cumulative exposure was 7.8 ppm-years and the estimated average annual serum level was 0.35 µg/mL. A significant positive trend was found for kidney cancer with the SMR=2.66 (n = 8; 95% CI 1.15, 5.24) for workers in the highest quartile. The most recent report on the same cohort included 6,026 workers evaluated for disease incidence, based on self-report with validation from medical records (Steenland et al. 2015). Lifetime serum cumulative dose was estimated by combining occupational and nonoccupational exposures. Median measured serum level was 0.113 µg/mL based on samples collected in 2005. Bladder cancer incidence (n = 29 cases) decreased with increased PFOA levels (RR 1.0, 0.55, 0.47, and 0.31 across quartiles, trend p = 0.03). Prostate cancer risk increased in Q1 compared to Q2 (n = 1.92), and remained at this level in the remaining quartiles (RR 1.89 and 2.15 in Q3 and Q4, respectively, trend p = 0.10).

Cholecystokinin (CCK) is a peptide hormone that stimulates the digestion of fat and protein, causes the increased production of hepatic bile, and stimulates contraction of the gall bladder. Research in rats suggests that pancreas acinar cell adenomas observed in rodents might be the result of increased CCK levels secondary to blocked bile flow (Obourn et al. 1997). CCK was measured in male workers (n = 74 males) at the 3M's Cottage Grove plant in 1997 as part of the medical surveillance program (Olsen et al. 1998, 2000). Employees' serum PFOA levels were stratified into three categories (<1, 1– <10, and ≥10 ppm). The mean CCK values for the three PFOA categories were 33.4, 28.0, and 17.4 pg/mL, respectively. The means in the two serum categories < 10 ppm were at least 50% higher than in the ≥ 10 ppm category. A statistically significant negative association between mean CCK levels and the three PFOA categories was observed (p = 0.03). A multiple regression model of the natural log of CCK and serum PFOA levels continued to display a negative association after adjusting for potential confounders. As stated previously (Olsen et al. 2000), no abnormal liver function, hypolipidemia, or cholestasis was observed in the workers. The authors suggested that the lack of a positive association between PFOA and CCK in workers could have resulted from serum PFOA levels too low to cause an increase in CCK provided that the same mechanism that increases CCK levels in rodents exists in humans.

High-exposure community studies. Vieira et al. (2013) investigated the relationship between PFOA exposure and cancer among the residents living near the DuPont plant in Parkersburg, West Virginia. This analysis included incident cases of 18 cancers diagnosed from 1996–2005 in five Ohio counties and eight West Virginia counties that included public water districts contaminated with PFOA. The dataset included 7,869 cases from Ohio geocoded to residence and 17,238 cases from West Virginia linked to water district. Exposure levels and serum PFOA concentrations were estimated based on residence at time of diagnosis, using modeled data based on previous work in the C8 study population (Shin et al. 2011). Individual-level exposure was categorized as very high, high, medium, low, or unexposed based on serum concentrations of >0.110 µg/mL, 0.0308–0.109 µg/mL, 0.0129–0.0307 µg/mL, 0.0037–0.0129 µg/mL, and unexposed (background levels not given), respectively. Logistic regression was applied to

individual-level data to calculate ORs and CIs for each cancer category. Data were first analyzed by water district. The adjusted ORs were increased for testicular cancer and for kidney cancer (OR: 5.1, 95% CI: 1.6, 15.6; n = 8 and OR: 1.7, 95% CI: 0.4, 3.3; n = 10, respectively) in the Little Hocking water district and for kidney cancer (OR: 2.0, 95% CI: 1.3, 3.1; n = 23) in the Tupper Plains water district. Both districts are in Ohio. Residents of Little Hocking also had increased OR for non-Hodgkin lymphoma (OR: 1.6, 95% CI: 0.9, 2.8; n = 14) and prostate cancer (OR: 1.4, 95% CI: 0.9, 2.3; n = 36). The analysis by exposure level for kidney and testicular cancers is shown in Table 3-12. Kidney cancer was positively associated with very high and high exposure categories (OR: 2.0, 95% CI: 1.0, 3.9; n = 9 and OR: 2.0, 95% CI: 1.3, 3.2; n = 22, respectively), while ORs for medium and low exposure categories were close to the null when compared to the unexposed category. The largest OR was for testicular cancer with the very high exposure category (OR: 2.8, 95% CI: 0.8, 9.2; n = 6), but the estimate was imprecise because of the small numbers. ORs for the other exposure categories were all <1.0. Ovarian cancer, non-Hodgkin's lymphoma, and prostate cancer were positively associated with the very high exposure category, but showed weaker or negative associations for the other exposure categories (Vieira et al. 2013).

Barry et al. (2013) extended the study of cancer incidence in the C8 Health Project population in an analysis of data from 32,254 study participants; there is some overlap in the cases included in Vieira et al (2013) and in Barry et al. (2013). The cohort included 3,713 current and former DuPont Washington Works employees, but results for this subset were limited by the small sample size for cancers of interest. Median serum PFOA levels, measured in 2005–2006 at enrollment in C8, were 0.024 and 0.113 µg/mL for community and worker populations, respectively. A proportional hazard regression model was run for each cancer type with the cancer as the outcome, time-varying cumulative PFOA serum concentration as the independent variable, and age as the time scale. Cumulative PFOA serum concentrations were estimated based on historical regional monitoring data and individual residential histories. Self-reported cancers were validated through a cancer registry or medical record. Confounders included smoking, alcohol consumption, gender, education, and 5-year birth year period. Testicular cancer risk was significantly increased with an increase in the log of estimated cumulative PFOA serum level (HR: 1.34, 95% CI: 1.00, 1.79; n = 17). Using estimated cumulative PFOA serum concentration quartiles, a significant monotonic trend was found for testicular cancer. Slight nonsignificant increases were seen for kidney cancer (HR: 1.10, 95% CI: 0.98, 1.24; n = 105) and for thyroid cancer (HR: 1.10, 95% CI: 0.95, 1.26; n = 86) (Barry et al. 2013).

Members of the C8 Health Project were evaluated for an association between serum PFOA levels and incidence of colon or rectal cancer (Innes et al. 2014). This cross-sectional study compared serum PFOA (and PFOS) levels at enrollment with diagnosis of primary colorectal cancer; 47,151 cancer-free adults and 203 cases were included. Serum PFOA levels ranged from <0.0005 to 22.4 µg/mL, with an average of 0.0866 µg/mL. An inverse relationship was found between PFOA level and diagnosis of colorectal cancer with OR = 0.64 (95% CI 0.44, 0.94; highest to lowest quartile, p for trend = 0.002). A concentration-related inverse association also was found between PFOS and colorectal cancer.

In 2012, the C8 Science Panel concluded that there is a probable link between exposure to PFOA and testicular and kidney cancer, but no other types of cancers. Their conclusion was based on the studies presented above, other epidemiology studies on cancer incidence in the mid-Ohio population, worker cohorts, and published data. Panel studies addressed 21 different

categories of cancer and looked for positive trends with increasing exposure as measured by cumulative serum levels.

General population studies. Eriksen et al. (2009) examined the association between plasma PFOA concentration and the risk of cancer in the general Danish population. The study population was chosen from individuals (aged 50–65 years) who had enrolled in the prospective Danish cohort Diet, Cancer and Health study between December 1, 1993, and May 31, 1997. The Danish Cancer Registry and Danish Pathology Data Bank were used to identify cancer patients diagnosed between December 1, 1993, and July 1, 2006. The cancer patients (n = 1,240) consisted of 1,111 males and 129 females whose median age was 59 years and who had prostate cancer (n = 713), bladder cancer (n = 332), pancreatic cancer (n = 128), or liver cancer (n = 67). The individuals (n = 772) in the subcohort comparison group were randomly chosen from the cohort study and consisted of 680 males and 92 females whose median age was 56 years. The participants each answered a questionnaire upon enrollment in the cohort study, and data on known confounders were obtained from the questionnaires. The plasma PFOA concentrations, based on blood samples provided by cancer patients at enrollment (1993–1997) were as follows: males 0.0068 µg/mL, females 0.0060 µg/mL, prostate cancer 0.0069 µg/mL, bladder cancer 0.0065 µg/mL, pancreatic cancer 0.0067 µg/mL, and liver cancer 0.0054 µg/mL. The plasma PFOA concentrations for the subcohort comparison group were 0.0069, 0.0054, and 0.0066 µg/mL for males, females, and combined, respectively. IRRs, crude and adjusted for confounders, did not indicate an association between plasma PFOA concentration and prostate, bladder, pancreatic, or liver cancer (see Table 3-12 for bladder cancer results). The plasma PFOA levels in the population were lower than those observed in occupational cohorts. This study is novel in that it is the first to examine PFOA levels and cancer in the general population.

A subset of females enrolled in the Danish National Birth Cohort was evaluated for an association between plasma PFOA levels (as well as 15 other PFASs) measured during pregnancy and risk of breast cancer during a follow-up period of 10–15 years (Bonefeld-Jørgensen et al. 2014). A total of 250 females diagnosed with breast cancer were matched for age and parity with 233 controls. The mean PFOA level in the controls was 0.0052 µg/mL while levels in the cases were divided into quintiles ranging from <0.0037 up to >0.0065 µg/mL. No association was found between PFOA levels and breast cancer risk. A weak positive association was found only with perfluorooctane sulfonamide.

Hardell et al. (2014) investigated an association between prostate cancer and levels of perfluoroalkyl acids (PFAAs) in whole blood. Patients with newly diagnosed prostate cancer (n = 201) had median PFOA levels of 0.002 µg/mL while the case-control group (n = 186) had a median level of 0.0019 µg/mL. PFOA levels were not associated with higher risks of prostate cancer when compared to controls or when analyzed according to Gleason score (pathology grade) and prostate-specific antigen. A significantly higher risk for prostate cancer was found for PFOA levels above the median combined with a first-degree relative with prostate cancer, indicating a genetic risk factor.

Two studies found no differences in blood and tissue PFOA levels between cancer and noncancer patients; the types of cancer in the patients were not defined. Vassiliadou et al. (2010) found that median serum PFOA concentrations among 40 cancer patients (0.00227 µg/mL in males; 0.00185 µg/mL in females) were similar to two control groups (0.00314 and 0.00181 µg/mL in males; 0.0017 and 0.00171 µg/mL in females). Yeung et al. (2013) found similar PFOS levels in serum and liver tissue between controls and those with hepatocellular carcinoma. Median serum levels in controls (n = 25) and patients with liver cancer (n = 24) were 0.00234

and 0.0025 µg/mL, respectively, and liver tissue were 0.506 (n = 9) and 0.495 (n = 12) ng/g, respectively.

3.1.2.1 Summary and Conclusions from the Human Cancer Epidemiology Studies

Evidence of carcinogenic effects of PFOA in epidemiology studies is based on studies of kidney and testicular cancer. These cancers have relatively high 5-year survival rates of 73% for kidney cancer and 95% for testicular cancer (based on National Cancer Institute [NCI] Surveillance, Epidemiology, and End Results data for 2005–2011). Thus studies that examine cancer incidence are particularly useful for these types of cancer. The high-exposure community studies also have the advantage for testicular cancer of including the age period of greatest risk, as the median age at diagnosis is 33 years. The two occupational cohorts in Minnesota and West Virginia (most recently updated, respectively, in Raleigh et al. 2014 and Steenland and Woskie 2012) do not support an increased risk of these cancers, but each of them is limited by a small number of observed deaths and incident cases. Two studies involving members of the C8 Health Project showed a positive association between PFOA levels (mean at enrollment of 0.024 µg/mL) and kidney and testicular cancers (Barry et al. 2013; Vieira et al. 2013). There is some overlap in the cases included in these studies. None of the general population studies examined kidney or testicular cancer, but no associations were found in the general population between mean serum PFOA levels up to 0.0866 µg/mL and colorectal, breast, prostate, bladder, or liver cancer (Bonfeld-Jørgensen et al. 2014; Eriksen et al. 2009; Hardell et al. 2014; Innes et al. 2014).

As part of the C8 Health Project, the C8 Science Panel (2012) concluded that a probable link existed between PFOA exposure and testicular and kidney cancer.

A group of independent toxicologists and epidemiologists critically reviewed the epidemiological evidence for cancer based on 18 studies of occupational exposure to PFOA and general population exposure with or without coexposure to PFOS. The project was funded by 3M, but the company was not involved in the preparation or approval of the report. The authors evaluated the published studies based on the study design, subjects, exposure assessment, outcome assessment, control for confounding, and sources of bias. They followed the Bradford Hill guidelines on the strength of the association, consistency, plausibility, and biological gradient in reaching their conclusion. They found a lack of concordance between community exposures and occupational exposures one or two magnitudes higher than those for the general population. The discrepant findings across the study populations were described as likely due to chance, confounding, and/or bias (Chang et al. 2014).

3.2 Animal Studies

Acute and short-term studies in monkeys, rats, and mice provide data on systemic toxicity and MoA. Subchronic studies in monkeys and rats found decreased body weight, increased liver weight accompanied by microscopic lesions, and decreased serum cholesterol. The most prominent microscopic lesion of the liver in both monkeys and rats was centrilobular hepatocellular hypertrophy. Data from studies of inhalation and dermal exposures are limited.

Chronic exposure studies were conducted in monkeys, rats, and mice providing information on tumor incidences for both rats and mice. Effects on development and reproduction were found in both rats (a 2-generation study) and mice (male fertility) and included developmental delays and increased neonatal mortality. Many developmental studies focused on the impact of

gestational/lactational exposure on mammary gland development and effects observed in offspring at maturity.

3.2.1 Acute Toxicity

Oral Exposure

Dean and Jessup (1978) reported an oral lethal dose for 50% of animals (LD₅₀) of 680 mg/kg and 430 mg/kg PFOA for male and female CD rats, respectively. Glaza (1997) reported an oral LD₅₀ of greater than 500 mg/kg in male Sprague-Dawley rats and between 250 and 500 mg/kg in females. Gabriel (1976a) reported an oral LD₅₀ of less than 1,000 mg/kg for male and female Sherman-Wistar rats. According to the Hodge Sterner Scale, these LD₅₀ values suggest that PFOA can be classified as moderately toxic after acute oral exposures.

Rigden et al. (2015) exposed groups of five male Sprague-Dawley rats to doses of 0, 10, 33, and 100 mg/kg/day for 3 days and maintained them for 4 additional days with daily body weight measurement and overnight collection of urine. Following the recovery period, the animals were sacrificed with collection of serum samples for analysis. Major organs were weighed, and the liver homogenized. The serum samples, liver homogenate, and supernatant were kept frozen at -80°C until they were analyzed. Phase I and II drug metabolizing enzymes and palmitoyl-coenzyme A (-CoA) oxidase were measured in the liver homogenate. Urine was analyzed for malondialdehyde (MDA) and 8-hydroxydeoxyguanine. The results for PFOA were compared with those for 100-mg/kg/day doses of di(2-ethylhexyl) phthalate (DEHP) and fenofibrate, known inducers of PPAR α .

There was a dose-related statistically significant increase in palmitoyl-CoA oxidase and liver weight at all PFOA doses. The palmitoyl-CoA increase was not significant for DEHP and fenofibrate with 100-mg/kg doses; liver weight increased significantly for fenofibrate but not DEHP. The only serum parameter that showed a significant dose-related response with PFOA was a decrease in uric acid compared to controls. Serum was analyzed for several minerals, proteins, enzymes (e.g., ALP, AST, ALT), glucose, cholesterol, and triglycerides. Phase I drug metabolizing enzyme activities (ethoxyresorufin-O-deethylase [EROD] and pentoxyresorufin-O-depentilase [PROD]) were significantly increased at the 100-mg PFOA/kg/day dose, and glutathione-S-transferase (GST) activity was significantly decreased at the two highest doses, but not in a dose-related fashion. UDP-glucuronyltransferase (UDP-GT) was significantly lower than controls at all doses, but the changes did not demonstrate a dose-related response. There were no dose-related significant changes for the other analytes. The 10-mg PFOA/kg/day dose administered for 3 days was a LOAEL for effects on the liver associated with PPAR α activation and for a decrease in serum uric acid. PFOA at 10 mg/kg/day for 3 days had a stronger impact on liver weight and palmitoyl-CoA activation than 100 mg/kg/day of DEHP and fenofibrate for the same exposure duration (Table 3-13). The 10-mg/kg/day dose was a LOAEL for liver effects usually associated with PPAR α activation. The PFOA response was stronger than that for a 100-g/kg/day dose for the two known activators of PPAR- α .

Table 3-13. Comparison of PPAR- α Related Effects in Rats for PFOA, DEHP, and Fenofibrate after a 3-day Exposure

Chemical	Dose mg/kg/day	Liver wt. g	Palm. CoA abs/min/g prot	EROD nmol/min/mg prot	PROD nmol/min/mg prot	UDP-GT nmol/min/mg prot	GST nmol/min/mg prot
Control	0	4.28 \pm 0.20	1.02 \pm 0.37	0.066 \pm 0.022	0.045 \pm 0.012	1.69 \pm 0.12	1.21 \pm 0.11
PFOA	10	5.73 \pm 0.29*	3.17 \pm 0.65*	0.096 \pm 0.024	0.080 \pm 0.024	0.88 \pm 0.09*	1.11 \pm 0.09
PFOA	33	6.40 \pm 0.20*	4.89 \pm 0.79*	0.080 \pm 0.015	0.078 \pm 0.031	1.00 \pm 0.14*	0.88 \pm 0.12*
PFOA	100	6.62 \pm 0.47*	6.11 \pm 1.51*	0.113 \pm 0.025*	0.107 \pm 0.029*	1.12 \pm 0.20*	0.94 \pm 0.19*
DEHP	100	4.14 \pm 0.34	1.40 \pm 1.09	0.060 \pm 0.012	0.039 \pm 0.031	1.45 \pm 5031	1.27 \pm 0.11
Feno-fibrate	100	5.73 \pm 0.24*	1.71 \pm 0.58	0.060 \pm 0.016	0.046 \pm 0.020	1.09 \pm 0.14*	0.94 \pm 0.13*

Notes: Mean \pm SD

* Significant ANOVA followed by Dunnett post-hoc test $p < 0.05$.

Inhalation Exposure

Rusch (1979) reported no mortality in male or female Sprague-Dawley rats following inhalation exposure to 186,000 mg/m³ PFOA for 1 hour. Kennedy et al. (1986) reported a 4-hour lethal concentration for 50% of animals (LC₅₀) of 980 mg/m³ for groups of six male rats exposed to PFOA as a dust in air. As reported in a later publication (Kennedy et al. 2004), body weight loss, irregular breathing, and red discharge around the nose and eyes were observed. Corneal opacity and corrosion were seen at concentrations greater than or equal to 810 mg/m³.

Dermal/Ocular Exposure

The dermal LD₅₀ in New Zealand White rabbits was determined to be greater than 2,000 mg/kg (Glaza 1995). Kennedy (1985) determined a dermal LD₅₀ of 4,300 mg/kg for rabbits, 7,000 mg/kg for male rats, and 7,500 mg/kg for female rats. The animals lost body weight and exhibited lethargy, labored breathing, diarrhea, and severe skin irritation (Kennedy et al. 2004). PFOA is an ocular irritant in rabbits when the compound is not washed from the eyes (Gabriel 1976b), but is not an irritant in rabbits when washed from the eye (Gabriel 1976c). Markoe (1983) found PFOA to be a skin irritant in rabbits, while Gabriel (1976d) did not conclude that PFOA is a skin irritant.

3.2.2 Short-Term Studies

Oral Exposure

Monkey. In a range-finding study, Thomford (2001) administered PFOA to male cynomolgus monkeys as an oral capsule containing 0, 2, and 20 mg/kg/day PFOA for 4 weeks. There were three monkeys in the 2- and 20-mg/kg/day groups and one monkey in the control group. Animals were observed twice daily for mortality and moribundity and were examined at least once daily for signs of poor health or abnormal behavior. Body weights were recorded weekly and food consumption was assessed qualitatively. The monkeys were fasted overnight and blood samples were collected 1 week prior to the start of the study and on day 30 for measurement of serum PFOA, clinical hematology, and clinical chemistry, plus analysis for hormones (estradiol, estrone, estriol, TSH, total and FT3, and total and FT4). Blood samples also were collected from each animal on day 2 (approximately 24 hours after the first dose) for clinical chemistry measurements.

At scheduled necropsy, liver samples were collected for palmitoyl-CoA oxidase activity (a biomarker for peroxisome proliferation) and serum PFOA. Liver, testes, and pancreas were collected and assayed for cell proliferation using antibodies to proliferating cell nuclear antigen (PCNA). Bile was collected from each animal for measurement of bile acid. The adrenals, liver, pancreas, spleen, and testes from each animal were examined microscopically.

All animals survived to scheduled sacrifice. There were no clinical signs of toxicity in the treated groups and there was no effect on body weight. Low or no food consumption was observed for one animal given 20 mg/kg/day. There were no effects on the hormones measured with the exception of estrone, which was notably lower in the 2- and 20-mg/kg/day PFOA groups. There was no evidence of peroxisome proliferation or cell proliferation in the liver, testes, or pancreas of the treated monkeys. No adverse effects were noted in either the gross or clinical pathology evaluations. Under the conditions of this study, the NOAEL was 20 mg/kg and no LOAEL was established.

Rat. Pastoor et al. (1987) dosed male Crl:CD (SD) BR rats (n = 6 per group) for 1, 3, and 7 days with 0 and 50 mg PFOA/kg. Liver sections were collected at necropsy and stained with hematoxylin and eosin. Sections also were examined by electron microscopy. DNA content was also determined for the livers of rats dosed for 7 days. Treatment with 50 mg PFOA/kg for 7 days caused a 17% decrease ($p < 0.05$) in mean body weight. Pair-fed control rats had a 24% decrease in body weight. Body weight was no different in the rats treated for 1 and 3 days than in the control rats. Liver weight of rats treated for 1 day was no different than control liver weight. The relative liver weight of rats treated for 3 days was significantly increased ($p < 0.05$) compared to control relative liver weight. Absolute and relative liver weights were significantly increased ($p < 0.05$) after the 7-day treatment with PFOA. A 57% decrease ($p < 0.05$) was observed in relative hepatic DNA/g liver, but no difference was observed between total amount of hepatic DNA/liver and total amount of DNA/liver in control rats.

The hepatocytes of rats treated with PFOA for 3 days were enlarged with partially occluded sinusoids, and had numerous basophilic granules, eosinophilic granular material in the cytoplasm, and fewer perinuclear glycogen vacuoles compared to control hepatocytes. Enlarged hepatocytes with hyperplastic smooth endoplasmic reticulum (ER), increased mitochondria, increased peroxisomes, decreased rough ER, and increased autophagosomes with electron-dense material also were observed in the hepatocytes.

Loveless et al. (2008) administered 0, 0.3, 1, 10, and 30 mg linear PFOA/kg by oral gavage to groups of male CD rats (n = 10 per group) for 29 days. Body weight was recorded on days 0, 3, and 6–28. At necropsy, blood was collected for hematology, clinical chemistry, and corticosterone (CORT) measurements. Tissues were collected for weight and microscopic examination. Body weight, weight gain, hematocrit, and hemoglobin were reduced at ≥ 10 mg PFOA/kg/day. Increased reticulocytes and hematopoieses were observed in the rats dosed with 30 mg PFOA/kg/day. Total and non-HDL cholesterol were significantly reduced at 0.3 and 1 mg/kg/day compared to control. HDL cholesterol was significantly decreased at 0.3, 1, and 10 mg/kg/day. Triglyceride levels were significantly decreased at all doses except 1 mg/kg. Absolute liver weight (≥ 1 mg/kg/day) and relative liver weight (≥ 10 mg/kg/day) were significantly increased. Hepatocellular hypertrophy was graded as minimum to mild (0.3–1 mg/kg/day) and moderate (≥ 10 mg/kg/day), and focal necrosis was present at doses ≥ 10 mg/kg/day. Although not statistically significant, serum CORT was increased at ≥ 10 mg/kg/day. The decrease in cholesterol and triglycerides at the lowest dose are not necessarily adverse. The 1-mg/kg/day dose is classified as the NOAEL and the 10-mg/kg/day

dose as the LOAEL based on the observations of increased liver weight, hepatocellular hypertrophy, and hepatic necrosis at that dose. Data on several immunological endpoints were reported as part of the Loveless et al. (2008) publication. The immunological data from that study are included in section 3.3.2 of this report.

Cui et al. (2009) exposed male Sprague-Dawley rats (10 per group) to PFOA (96% active ingredient) at 0, 5, and 20 mg/kg/day for 28 days by gavage once daily. The activity of the rats was observed over the course of the study. All rats were sacrificed after the final exposure. The rats dosed with 5 mg/kg/day exhibited hypoactivity, decreased food consumption, cachexia, and lethargy during the third week of the study. Rats dosed with 20 mg/kg/day also exhibited sensitivity to external stimuli. The visceral index (i.e., hepatic, renal, gonad weight/animal's body weight) used to evaluate hyperplasia, swelling, or atrophy was significantly increased in the treated animals compared to control animals. In the liver, treatment with 5 or 20 mg PFOA/kg caused hepatic hypertrophy, fatty degeneration, and acidophilic lesions as well as angiectasis (gross dilation) and congestion in the hepatic sinusoid or central vein. In the lung, treatment with 5 or 20 mg PFOA/kg caused pulmonary congestion and focal or diffuse thickened epithelial walls. No histopathologic lesions were observed in the kidneys of the low-dose animals, but turbidness and swelling in the epithelium of the proximal convoluted tubule were observed at 20 mg PFOA/kg. Under the conditions of this study, the LOAEL was 5 mg/kg/day based on increased visceral indices, and liver and pulmonary lesions; no NOAEL was established.

Male Sprague-Dawley rats (n = 10 per group) were fed diets containing 0 and 300 ppm PFOA for 1, 7, and 28 days in two studies (Elcombe et al. 2010). The mean daily intake for study 1 and study 2 were 19 and 23 mg/kg/d, respectively. A group of rats was fed diets containing 50 ppm Wyeth 14,643, a PPAR α agonist, as a positive control. The animals were observed daily and body weights and food consumption were recorded. At necropsy, day 2, day 8, or day 29, the organs were weighed, examined for gross pathology and preserved for histopathology. In study 1, liver DNA content and concentration were determined, and plasma was collected for analysis of liver enzymes, cholesterol, triglycerides, and glucose. Hepatic cell proliferation and apoptosis also were determined.

In both studies, body weight significantly decreased ($p < 0.05$) after 7 and 28 days on the PFOA diet. Body weight was not affected by Wyeth 14,643. Absolute liver weight was significantly increased ($p < 0.05$) in rats fed PFOA diets for 7 days in the first study and in rats treated for 7 and 28 days in the second study (Table 3-14). The liver-to-body-weight ratio was significantly higher in rats fed PFOA diets for 7 and 28 days in both studies. Absolute liver weight and liver-to-body-weight ratios were significantly increased in rats fed the Wyeth 14,643 diet in both studies.

After 1 day of eating the PFOA diet, subjects' plasma AST was significantly decreased and triglycerides were significantly increased. After 7 and 28 days on the PFOA diet, TC, triglycerides, and glucose levels were significantly decreased. The AST response did not show a duration-related response because there was a significant decrease at 1 and 28 days, but not at 7 days on the PFOA diet. Liver DNA concentration was significantly decreased ($p < 0.05$) in all PFOA-exposed rats except those treated for 1 day in the second study, but liver DNA content was not altered by PFOA, suggesting that the increase in volume was responsible for the change in concentration.

Table 3-14. Hepatic Effects of Rats Exposed to PFOA

	Day	Study 1			Study 2		
		Control	300 ppm PFOA (19 mg/kg/day)	50 ppm Wyeth 14,643	Control	300 ppm PFOA (32 mg/kg/day)	50 ppm Wyeth 14,643
Liver weight (g)	1	13.6 ± 1.3	14.1 ± 2.4	15.7 ± 1.2	15.2 ± 1.9	14.4 ± 0.9	15.8 ± 1.4
	7	15.3 ± 1.3	19.2 ± 3.1*	23.1 ± 3.1*	16.6 ± 1.7	22.8 ± 2.6*	23.4 ± 2.5*
	28	18.3 ± 2.5	20.8 ± 3.2	30.6 ± 3.2*	17.2 ± 2.0	24.6 ± 2.2*	29.2 ± 4.0*
Liver-to-bw (g/kg)	1	4.25 ± .34	4.39 ± 0.44	4.64 ± 0.17*	4.39 ± 0.36	4.27 ± 0.14	4.49 ± 0.23
	7	4.10 ± 0.26	5.83 ± 0.55*	6.26 ± 0.48*	4.28 ± 0.24	6.56 ± 0.38*	6.34 ± 0.33*
	28	3.96 ± 0.36	5.83 ± 0.56*	7.09 ± 0.42*	3.70 ± 0.21	6.13 ± 0.53*	6.65 ± 0.59*
Labeling index (%)	1	0.22 ± 0.17	0.74 ± 0.55*	2.10 ± 1.10*	1.02 ± 0.37	2.18 ± 0.73*	4.54 ± 1.03*
	7	1.42 ± 0.65	5.94 ± 2.12*	12.56 ± 6.42*	2.57 ± 1.31	13.18 ± 3.18*	23.85 ± 7.02*
	28	ND	2.08 ± 1.03	10.15 ± 2.69	0.66 ± 0.45	1.74 ± 0.96*	5.34 ± 2.79*

Source: Elcombe et al. 2010

Notes: *Significantly different from control (p < 0.05); ND = No Data.

After 1 day on the Wyeth 14,463 diet, subjects' AST and TC were significantly decreased. After 7 and 28 days on the Wyeth 14,643 diet, subjects' ALT, TC, triglycerides, and glucose levels were significantly decreased. AST was not significantly decreased in rats fed Wyeth 14,643 diets for 28 days, but it was after 7 days. In the Wyeth 14,643 rats, liver DNA concentration was significantly decreased after 1 and 7 days in the first study and 7 and 28 days in the second study. Total liver DNA content in the Wyeth 14,643-treated rats was significantly increased after 7 and 28 days in both studies.

Labeling indices for hepatic cell proliferation, as measured by bromodeoxyuridine (5-bromo-2-deoxyuridine, BrdU) incorporation, was significantly increased after day 1 and 7 in study 1 in both PFOA (p<0.05) and Wyeth 14,643 (p<0.01) diet-fed rats. Samples from control livers at day 29 were not available for comparison. In study 2, labeling was significantly increased (p<0.05) at all time points in both groups of rats compared to labeling in control rats (Table 3-14). Apoptosis of hepatic cells was not altered by treatment with PFOA at any time point. In rats fed diets containing Wyeth 14,643 for 28 days, hepatic apoptosis was significantly decreased (p<0.01) compared to apoptosis observed in control livers.

Histological examination of the livers of PFOA and Wyeth 14,643 diet-fed rats showed decreased glycogen after 1, 7, and 28 days. An increase in hepatocellular hypertrophy was observed after 7 and 28 days on the diets, fatty vacuolation was observed after 7 days on the diets, and increased hepatocellular hyperplasia was observed after 28 days on the diets. The hepatic observations were similar in both studies, and findings in Wyeth 14,643 diet-fed rats were generally more pronounced or severe than those in PFOA diet-fed rats. Although there were many similarities in response to the PFOA and Wyeth 14,463 diets, the body weight and apoptosis responses differed.

Mouse. Kennedy (1987) fed male and female Crl:CD-1 mice diets containing 0, 30, 300, and 3,000 ppm PFOA for 14 days. At necropsy body weight and liver weight were recorded and analyzed. No histological evaluations were conducted. All mice died at 3,000 ppm. At 300 ppm, body weight was decreased and one female died. Both male and female mice had significantly increased absolute and relative liver weights at all doses (p<0.05) compared to the control. The

LOAEL was 30 ppm based on increased liver weight, and no NOAEL was established. Kennedy (1987) used lower doses in a follow-up study lasting 21 days. Male and female mice were fed diets containing 0, 0.01, 0.03, 0.1, 0.3, 1, 3, 10, and 30 ppm PFOA. Absolute and relative liver weights for male and female mice were significantly increased ($p < 0.05$) at ≥ 3 ppm PFOA. The LOAEL was 3 ppm based on increased liver weight, and the NOAEL was 1 ppm.

Loveless et al. (2008) administered 0, 0.3, 1, 10, and 30 mg linear PFOA/kg by oral gavage to groups of male CD-1 mice ($n = 20$ per group) for 29 days. Body weight was recorded on days 0, 3, and 6–28. At necropsy, blood was collected for hematology, clinical chemistry, and CORT measurements. Tissues were collected for weight and microscopic examination. Body weight was significantly reduced at 10 and 30 mg/kg/day. An increase in neutrophils and monocytes was observed at ≥ 10 mg/kg/day along with a decrease in eosinophils. Serum CORT levels were significantly increased in mice dosed with 10 mg/kg and elevated in those dosed with 30 mg/kg/day. Total serum cholesterol and triglycerides were significantly decreased at ≥ 10 mg/kg/day. HDL was significantly reduced at ≥ 1 mg/kg/day. In mice treated with 30 mg/kg and water, triglycerides and HDL levels were significantly decreased compared to control levels. Absolute and relative liver weights were significantly increased at ≥ 1 mg PFOA/kg/day. Increased incidences of microscopic lesions in the liver included mild hepatocellular hypertrophy at 0.3 mg/kg/day, moderate-to-severe hypertrophy and individual cell necrosis at ≥ 1 mg/kg/day, and increased hepatocellular mitotic figures, fatty changes, and bile duct hyperplasia at ≥ 10 mg/kg/day. The LOAEL for this study was 1 mg/kg/day based on increased liver weight, hepatocellular hypertrophy, and cell necrosis; the NOAEL was 0.3 mg/kg/day. Data on several immunological endpoints were reported as part of the Loveless et al. (2008) publication. The immunological data are included in section 3.3.2 of this report.

Some of the epidemiology studies report that evaluated serum lipids demonstrate a positive correlation between total serum cholesterol and triglycerides and serum PFOA. Tan et al. (2013) used male C57BL/6N mice to determine if dietary fat content could be an important variable influencing the impact of PFOA on serum lipids. Groups of seven or eight 4-month-old male mice were given either a liquid regular fat diet (RFD) or a high-fat diet (HFD), with or without PFOA, for 3 weeks. The RFD provided 12% and the HFD provided 35% of their calories from fat. Calories from protein (18%) were equivalent in both diets. The RFD provided 60% and the HFD provided 40% of their calories from carbohydrate. The fats were primarily monounsaturated (olive oil) or polyunsaturated (safflower and corn oil). PFOA was added to both diets for 3 weeks at a level that maintained a dose of 5 mg/kg/day to the mice. The PFOA-treated groups were fed *ad libitum*, and the control groups were given the amount consumed by the PFOA-treated groups the previous day. Body weight; liver weight; plasma ALT, AST, and ALP; total and direct bilirubin; free fatty acids and liver triglycerides; as well as subcutaneous and epididymal white adipose tissue were monitored. Statistical differences between groups ($p < 0.05$) were determined using one-way ANOVA. Liver and epididymal white fat tissue samples were examined histologically.

The fat content of the diets alone resulted in significant differences in body weight and subcutaneous white adipose tissue, but not in liver weight. The addition of PFOA to the RFD resulted in significant increases in body weight, liver weight, ALT, ALP, and plasma free fatty acids, but not in AST or bilirubin. The addition of PFOA to both the RFD and HFD resulted in decreases in the mass of both epididymal and subcutaneous white fat deposits.

The HFD alone did not result in definitive alterations in liver histopathology. When PFOA was added to the RFD, indications of hepatocyte hypertrophy, necrosis, and inflammatory cell

infiltration were observed. The liver damage in the animals being fed the HFD with PFOA was increased more than in the RFD-PFOA animals, as indicated by higher levels of necrosis and inflammation accompanied, in this case, by lipid droplet accumulation and significantly increased liver triglycerides, but not liver cholesterol or free fatty acids. In the epididymal adipose tissues, adipocyte size was increased in the HFD control compared to the RFD control but decreased with the addition of PFOA compared to both the RFD and HFD controls. Inflammatory cell infiltration was observed in the epididymal adipose tissues when PFOA was added to the HFD but not the RFD. No data for the subcutaneous white fat tissues was provided.

The authors evaluated the hepatic expression of 84 genes involved in the regulation of fatty acid metabolism using RT² Profiler PCR Arrays. HFD and/or PFOA altered the expression of 33 genes (> 1.5 fold). PFOA alone upregulated 13 genes (>1.5) and downregulated 4 (>1.5) genes with fatty acid and triglyceride catabolism. Eight fatty acid transport-related genes were upregulated by PFOA and one was downregulated. The study demonstrates the importance of the fat content of the diet as a modulator of the effects of PFOA on the liver in animals. Damage to the liver tissues was intensified in the presence of the HFD.

Son et al. (2008) administered 0, 2, 10, 50, and 250 mg/L PFOA (0, 0.49, 2.64, 17.63, and 47.21 mg/kg PFOA, respectively) in the drinking water to 4-week-old male imprinting control region (ICR) mice for 21 days. Food and water consumption, and body weight were recorded daily. At sacrifice, blood was collected and the liver and kidneys were removed and weighed. Plasma from the blood was used to determine levels of ALT, AST, BUN, and creatinine. Sections of the liver and kidney were processed and stained with hematoxylin and eosin or stained for caspase 3 (a biomarker for apoptosis). Expression of mRNA for tumor necrosis factor- α , interleukin-1 β , and transforming growth factor- β were determined using reverse transcription polymerase chain reaction (RT-PCR).

The mice exposed to 250 mg/L PFOA (47.21 mg/kg/day) had significantly reduced food and water consumption ($p < 0.05$), and body weight gain ($p < 0.05$) compared to the control mice. Body weight gain also was significantly reduced ($p < 0.05$) in mice receiving 50 mg/L PFOA in the drinking water. In all PFOA-exposed mice, relative liver weight was significantly increased in a dose-dependent manner ($p < 0.05$) compared to liver weight of the control mice. Relative kidney weight was not affected by PFOA exposure. At ≥ 10 mg/L PFOA (2.64 mg/kg/day), plasma ALT activity was significantly increased, and at ≥ 50 mg/L PFOA (17.63 mg/kg/day), plasma AST activity was significantly elevated compared to the activity level in the control mice. Exposure to PFOA did not affect BUN or creatinine.

The livers of mice exposed to ≥ 50 mg/L PFOA were characterized by enlarged hepatocytes with acidophilic cytoplasm and the presence of eosinophils. No apoptotic bodies were observed in the liver with staining for caspase 3. Exposure to PFOA did not affect kidney morphology and did not cause toxic damage or necrosis in the kidney. In the liver, tumor necrosis factor- α expression was significantly reduced at ≥ 50 mg/L PFOA, interleukin-1 β expression was significantly reduced at 250 mg/L PFOA, and transforming growth factor- β expression was significantly elevated at ≥ 50 mg/L PFOA. Under the conditions of this study, the LOAEL was 2 mg/L (0.49 mg/kg/day) based on increased liver weight, and no NOAEL was established. The LOAEL for increased plasma ALT was 2.64 mg/kg/day.

Wolf et al. (2008a) gavaged wild-type 129S1/SvImJ mice ($n = 7-8$ per group) and PPAR α -null mice (129S4/SvJae-PPAR $\alpha^{\text{tm1Gonz/J}}$, $n = 6-8$ per group) with 0, 1, 3, or 10 mg PFOA/kg or 50 mg Wyeth 14,643, a PPAR α agonist, and wild-type CD-1 ($n = 7-8$ per group)

with 0, 1, and 10 mg PFOA/kg for 7 days to characterize hepatic effects resulting from exposure. The mice were sacrificed 24 hours following the last dosing. Blood was collected for serum, and the livers were removed and weighed. Liver sections were stained with hematoxylin and eosin for examination by light microscopy and with uranyl acetate for transmission electron microscopy. Liver sections were also processed for immunohistochemistry of PCNA. Hepatocyte hypertrophy and vacuolation, observed in both strains of wild-type mice, were assigned a score from 0 to 4 based on severity, with 0 being no lesions observed and 4 being panlobular hypertrophy with cytoplasmic vacuolation. Hepatic lesions in PPAR α -null were assigned a score (0–4) based on cytoplasmic vacuolation as no hypertrophy was observed. The percentage labeling index was obtained by counting the number of positive PCNA cells in 900–1,000 hepatocyte nuclei per animal. Slides were read blind to treatment but with knowledge of genetic status.

Compared to control values, the absolute and relative liver weights, lesion score, and labeling index were significantly increased ($p < 0.05$) in a dose-dependent manner in both strains of wild-type mice exposed to PFOA and also were significantly increased ($p < 0.05$) in the wild-type 129S1/SvImJ mice exposed to Wyeth 14,643 (see Table 3-15). The absolute and relative liver weights and lesion score were significantly increased ($p \leq 0.05$) in a dose-dependent manner in all PFOA-exposed PPAR α -null mice. The labeling index was significantly increased ($p < 0.05$) in PPAR α -null mice exposed to 10 mg PFOA/kg. Absolute and relative liver weights, lesion score, and labeling index of PPAR α -null mice exposed to Wyeth 14,643 were no different from control values.

Table 3-15. Hepatic Effects in PFOA-Treated Mice

Group	Liver Weight (g)	Relative Liver Weight (%)	Lesion Score	Labeling Index
Wild-type CD-1 Mice				
Control	1.53 ± 0.14	4.5 ± 0.4	0.3 ± 0.5	0.6 ± 0.4
1 mg/kg/day PFOA	2.26 ± 0.24*	6.5 ± 0.5*	2.1 ± 0.9	0.7 ± 0.5
10 mg/kg/day PFOA	3.48 ± 0.54*	10.5 ± 0.8*	3.0 ± 0*	7.7 ± 3.0*
Wild-type 129S1/SvImJ Mice				
Control	0.87 ± 0.08	3.3 ± 0.4	0.3 ± 0.5	0.3 ± 0.2
1 mg/kg/day PFOA	1.22 ± 0.22*	1.6 ± 0.2*	2.0 ± 0.0*	0.7 ± 0.6
3 mg/kg/day PFOA	1.70 ± 0.12*	6.4 ± 0.4*	2.0 ± 0.0*	1.0 ± 0.4
10 mg/kg/day PFOA	2.20 ± 0.23*	8.3 ± 0.2*	4.0 ± 0.0*	2.4 ± 0.9*
50 mg/kg/day Wyeth 14,643	1.5 ± 0.13*	5.6 ± 0.1*	3.3 ± 0.5*	2.1 ± 1.2*
PPARα-null Mice				
Control	0.92 ± 0.08	3.4 ± 0.4	1.1 ± 0.4	0.2 ± 0.2
1 mg/kg/day PFOA	1.2 ± 0.14*	4.5 ± 0.2*	1.9 ± 0.6*	0.6 ± 0.4
3 mg/kg/day PFOA	1.46 ± 0.21*	5.8 ± 0.3*	3.0 ± 0.0*	0.6 ± 0.3
10 mg/kg/day PFOA	2.8 ± 0.18*	9.4 ± 0.6*	4.0 ± 0.0*	7.7 ± 3.0*
50 mg/kg/day Wyeth 14,643	1.07 ± 0.24	3.9 ± 0.5	1.4 ± 0.5	0.6 ± 0.5

Source: Wolf et al. 2008a

Note: * Statistically different from control, $p < 0.05$.

Ultrastructure evaluations were done on liver sections from wild-type 129S1/SvImJ mice and PPAR α -null mice, but not from CD-1 mice. There were the expected differences in the characteristics of hepatocytes from the control wild-type mice when compared to both the PFOA-treated and Wyeth 14,643 wild-type mice. In the PPAR α -null mice, the responses of the control and Wyeth 14,643-dosed animals were similar, but the response of the PFOA-dosed animals differed. Table 3-16 summarizes the cellular characteristics of the hepatocytes for the control, PFOA-treated, and Wyeth 14,643-treated wild-type and PPAR α -null mice on the basis of their glycogen content, Golgi bodies and associated rough ER, mitochondria, peroxisomes, and lipid-like cytoplasmic vacuoles.

Table 3-16. Mouse Hepatocyte Ultrastructure After PFOA or Wyeth 14,643 Treatment

Mouse/Treatment	Characteristics				
	Glycogen	Golgi/ Rough ER	Mitochondria	Peroxisomes	Lipid-like Vacuoles
Wild-type/Control	Prominent	Prominent	Numerous	Few	Rare
Wild-type/PFOA (10 mg/kg)	Negative	Nominal/ scarce ER	Numerous	Numerous	Scattered
Wild-type/Wyeth	Negative	Nominal/ scarce ER	Numerous	Numerous	Scattered
PPAR α -null/Control	Prominent	Prominent	Numerous	Absent	Scattered
PPAR α -null/PFOA (10 mg/kg)	Limited	Limited	Not reported	Not reported	Numerous ^a
PPAR α -null/Wyeth	Prominent	Prominent	Numerous	Absent	Scattered

Source: Wolf et al. 2008a

Note: ^a Described as electron-dense, nonmembrane-bound spaces morphologically consistent with lipids ranging from the size of mitochondria to the size of nuclei. The vacuoles were believed to be an accumulation of PFOA.

It is apparent from the data in Table 3-16 that PFOA and Wyeth 14,643 behaved similarly in the wild-type strains but differently in the PPAR α -null mice. The hepatocytes of PFOA-dosed PPAR α -null mice exhibited lower glycogen content, Golgi bodies, and associated rough ER than both the control and Wyeth 14,643 PPAR α -null mice. In addition, the PFOA-dosed PPAR α -null mice had numerous large nonmembrane-bound lipid-like vacuoles throughout the cytoplasm. At the high dose (10 mg/kg/day), there was an increase in the labeling index that was not observed with Wyeth 14,643. The authors concluded that the large lipid-like vacuoles in the hepatocytes of PFOA-dosed PPAR α -null mice were likely accumulations of PFOA. Under the conditions of this study, the LOAEL was 1 mg/kg/day based on increased absolute and relative liver weight and hepatic morphology changes; no NOAEL was established.

Nakamura et al. (2009) investigated the functional difference in PFOA response between mice and humans using a humanized PPAR α transgenic mouse strain (hPPAR α). Humanized PPAR α mice express a high level of human PPAR α protein in the liver. Male 8-week-old wild-type (mPPAR α) mice, PPAR α -null mice, and hPPAR α mice were gavage-dosed with 0, 0.1, and 0.3 mg/kg/day PFOA (n = 4–6 per group) for 2 weeks and sacrificed 18–20 hours following the last dose. Blood was collected and analyzed for triglyceride and cholesterol concentrations, and ALT measurements. Livers were collected and analyzed for triglyceride and cholesterol concentrations, plus histopathological changes. The differences in the observations for the three strains of mice are summarized in Table 3-17.

Table 3-17. Relative Response of hPPAR α , mPPAR α , and PPAR α -null Mice to PFOA

Parameter	hPPAR α	mPPAR α	PPAR α -null
Liver weight	ND	↑ compared to control (0.3 mg/kg/day)	↓ compared to control (0.1 mg/kg/day)
Liver/body weight ratio	ND	↑ compared to control (0.3 mg/kg/day)	ND
Hepatocyte hypertrophy	Mild (0.3 mg/kg/day)	Mild (0.3 mg/kg/day)	ND
ALT	ND	ND	ND
Plasma cholesterol	↑ compared to mPPAR α (all doses)	ND	ND
Liver cholesterol	↓ compared to PPAR α -null (0.1, 0.3 mg/kg/day), mPPAR α (0.3 mg/kg/day)	↑ compared to control (0.3 mg/kg/day)	ND
Plasma triglyceride	ND	ND	ND
Liver triglyceride	↓ compared to PPAR α -null (0.3 mg/kg/day)	↓ compared to PPAR α -null (0.1, 0.3 mg/kg/day; ↑ compared to control (0.3 mg/kg/day)	↑ compared to mPPAR α (all doses)

Source: Nakamura et al. 2009

Notes:

hPPAR α : transgenic mice (that express a high level of human PPAR α protein in the liver); mPPAR α : wild-type mice.

↑ = significant increase (p < 0.05).

↓ = significant decrease (p < 0.05)

ND = no differences.

Body weight of the hPPAR α mice was slightly lower than the mPPAR α and PPAR α -null mice prior to PFOA treatment and remained lower throughout the dosing regimen. Treatment with PFOA did not affect plasma ALT or triglyceride concentrations in any group. The hPPAR α mice differed from the wild-type mice in that their plasma cholesterol was significantly increased and their liver cholesterol and triglycerides significantly decreased at the highest dose (Table 3-17). In addition, the increases in absolute and relative liver weights were less than those observed in the wild-type mice. The PPAR α -null mice differed from the wild-type in that liver triglycerides were significantly increased. Comparable to the Wolf et al. (2008a) report, the cytoplasmic vacuoles were larger in the PPAR α -null mice than in the wild-type and hPPAR α mice. There were no other significant differences between PPAR α -null mice and wild-type mice.

Under the conditions of the study, the LOAEL for mPPAR α mice was 0.3 mg/kg/day of PFOA based on increased liver weight and increased liver triglyceride and cholesterol concentrations. The NOAEL for mPPAR α mice was 0.1 mg/kg/day of PFOA. The NOAEL for PPAR α -null mice was 0.3 mg/kg/day because the changes in absolute liver weight were not dose-related and the increase in relative liver weight was not significantly different from the control. The NOAEL for hPPAR α mice was 0.3 mg/kg/day of PFOA, the highest dose tested. However, a nonsignificant but dose-related increase was observed in plasma cholesterol.

Minata et al. (2010) examined hepatobiliary injury in mice treated with PFOA. Male wild-type 129S4/SvImJ mice (n = 39) and PPAR α -null (129S4/SvJae-Ppara^{tm1Gonz}/J mice (n = 40) were orally dosed with 0, 12.5, 25, and 50 μ mol/kg/day of PFOA (equivalent to ~0, 5.4, 10.8, and 21.6 mg/kg/day of PFOA) for 4 weeks. At the end of 4 weeks, animals were sacrificed and blood, liver, and bile were collected for clinical chemistry analysis and determination of PFOA concentration. Sections of the liver were processed for histological examination, oxidative DNA damage, and multidrug resistance protein 2 (Mdr2) and tumor necrosis factor α (TNF- α) mRNA

expression. Bile acid and phospholipid contents in bile were determined as well as the protein expression of canalicular bile salt export pump (BSEP) and canalicular MRP2.

Absolute and relative liver weights in all PFOA treated wild-type and PPAR α -null mice were significantly increased ($p < 0.05$) at sacrifice compared to control liver weight. Plasma AST was significantly increased in wild-type mice at 25 and 50 $\mu\text{mol/kg/day}$ (equivalent to 10.8 and 21.6 mg/kg/day) and in PPAR α -null mice at 50 $\mu\text{mol/kg/day}$ compared to the concentrations of their respective controls. Plasma ALT was no different from control in the treated mice. In wild-type mice, total bilirubin was significantly decreased at 12.5 $\mu\text{mol/kg/day}$ and significantly increased at 50 $\mu\text{mol/kg/day}$. In PPAR α -null mice, total bilirubin was significantly increased at 50 $\mu\text{mol/kg/day}$. Total bile acid was significantly increased at 50 $\mu\text{mol/kg/day}$ in PPAR α -null mice. TC was significantly decreased in wild-type mice at 25 and 50 $\mu\text{mol/kg/day}$, and total triglyceride was significantly increased at 12.5 and 25 $\mu\text{mol/kg/day}$. TC was significantly decreased at 12.5 and 25 $\mu\text{mol/kg/day}$ and significantly increased at 50 $\mu\text{mol/kg/day}$ in PPAR α -null mice. In PPAR α -null mice, total triglycerides were significantly increased at all doses.

Hepatocellular hypertrophy was observed in wild-type mice treated with 12.5, 25, and 50 $\mu\text{mol/kg/day}$ (equivalent to 5.4, 10.8 and 21.6 mg/kg/day). A dose-dependent increase in eosinophilic cytoplasmic changes consistent with peroxisome proliferation was observed in liver parenchyma, but no fat droplets or focal necrosis were observed in wild-type mice. An increase in bile duct epithelium thickness suggested slight cholangiopathy in wild-type mice at 25 and 50 $\mu\text{mol/kg/day}$. Increased apoptosis in hepatic cells, hepatic arterial walls, and bile duct epithelium was observed at 25 and 50 $\mu\text{mol/kg/day}$ in wild-type mice. Ultrastructure examination of livers from PFOA-treated wild-type mice showed decreased glycogen granules, degranulated or disrupted rough ER, nuclear vacuoles, extensive peroxisome proliferation, and slight mitochondria proliferation.

In PPAR α -null mice treated with 12.5, 25, and 50 $\mu\text{mol/kg/day}$ of PFOA (equivalent to 5.4, 10.8 and 21.6 mg/kg/day), hepatocellular hypertrophy, cytoplasmic vacuolation, and increased microvesicular steatosis were observed. These observations are consistent with Wolf et al. (2008a). At 50 $\mu\text{mol/kg/day}$, focal necrosis was observed. Areas of bile fibrosis and bile plaque and few inflammatory cells were observed in the bile ducts of PPAR α -null mice at 25 and 50 $\mu\text{mol/kg/day}$. Increased apoptosis was observed in bile duct epithelium at 25 and 50 $\mu\text{mol/kg/day}$ in PPAR α -null mice. Ultrastructure examination of livers from PFOA-treated PPAR α -null mice showed decreased glycogen granules, degranulated or disrupted rough ER, increased cytoplasmic lipid accumulation, mitochondria proliferation, and mitochondrial changes (e.g., swelling and decreased matrix density). Peroxisome proliferation was not observed. Ultrastructure of bile duct showed degradation of cytoplasmic structure, vacuolization, disintegration of nuclei and organelles, periductal infiltration of fibroblasts and macrophages, and fibrosis.

The marker for oxidative damage, 8-hydroxydeoxyguanosine (8-OH-dG), and TNF- α were not elevated or upregulated in wild-type mice. In PPAR α -null mice, 8-OH-dG was elevated in the liver at 21.6 mg/kg/day and TNF- α mRNA was significantly increased at 10.8 and 21.6 mg/kg/day. The transporter Mdr2 moves biliary phospholipids from hepatocytes to bile and was significantly upregulated in wild-type mice at all doses, but only at 5.4 mg/kg/day in PPAR α -null mice. The BSEP transports bile acid from hepatocytes to bile and was significantly decreased in wild-type mice at 21.6 mg/kg/day, significantly increased in PPAR α -null mice at 5.4 mg/kg/day, and significantly decreased at 21.6 mg/kg/day. The transporter MRP2 also transports bile acid and was significantly decreased at 21.6 mg/kg/day in both groups of mice.

Under the conditions of the study, the LOAEL for male wild-type and PPAR α -null mice was 5.4 mg/kg/day of PFOA based on increased liver weight. A NOAEL was not established. At the LOAEL, the difference between the PPAR α -null mice and the wild-type mice was the presence of cytoplasmic vacuoles and microvesicular steatosis in addition to hypertrophy in the PPAR α -null mice.

The effects of gavage exposure on groups of six male Klunming mice (8 weeks old) to doses of 0, 2.5, 5, and 10 mg PFOA/kg/day for 14 days on the testes and epididymis was examined by Liu et al. (2015). The lowest dose tested was a LOAEL for dose-related effects on decreased sperm count, testicular superoxide dismutase (SOD), catalase, nuclear respiratory factor 2 (NRF2), and BAX expression ($0 < 0.05$) plus increases in MDA, hydrogen peroxide, BAX and BCL expression ($p < 0.05$). There was no effect on relative testes weight at any dose. Some effects were observed on testicular morphology at the lowest dose, including atrophy of the seminiferous tubules, depletion of spermatogonial cells, detachment of germ cells from the seminiferous epithelium, and decreased sperm production. The severity of the testicular morphological changes increased with dose. Six animals per dose group were used for the evaluation of testicular weight and 4 animals per dose group were used for the other assays. The increase in MDA and hydrogen peroxide accompanied by the decrease in SOD and carnitine acyltransferase (CAT) activity and NRF2 expression indicate that oxidative stress played a major role in the observed toxicity. NRF2 plays an important role as a messenger that upregulates genes involved in response to oxidative stress.

Lu et al. (2015) reported on the testicular effects of PFOA on the blood testes barrier after a 28-day exposure of BALBL/c male mice (14 days old) to gavage doses of 0, 1.25, 5, and 20 mg/kg/day (3–5 animals per dose group). The blood testes barrier divides the seminiferous epithelium into apical and basolateral compartments and plays an important role in germinal cell development and male fertility. The barrier prevents the passage of large molecules from one compartment to the other. At termination of the exposure, the animals were sacrificed and the testes recovered for analysis. A second component of this study examined the impact of the PFOA treatment on male fertility and is reported in section 3.2.6.

The blood testes barrier integrity was weakened at the lowest dose tested and in a dose-dependent manner as indicated by the passage of a red fluorescent dye injected into the interstitium and concentrations of IgG measure in gel electrophoresis columns visualized by chemiluminescence (three per dose group). Membrane integrity is dependent on coexisting tight junctions, basal ectoplasmic specializations, and gap junctions. Accompanying *in vitro* assays of cultured sertoli cells demonstrated downregulation of key proteins associated with the tight junction and gap junction intercellular communication (GJIC) and regulation of the ectoplasmic specialization protein N-cadheran. Tumor necrosis factor actin protein in the testes increased in a dose-related fashion at 5 and 20 mg/kg/day on observation of three per dose group. The authors identified the 5-mg/kg/day dose as a LOAEL for PFOA effects on the blood testes barrier and the 1.25-mg/kg/day dose as a NOAEL, apparently based on the results for the key protein biomarkers for cellular intercommunication rather than the IgE and fluorescence results where 1.25 mg/kg/day was a LOAEL.

Li et al. (2011) investigated the involvement of mouse and human PPAR α in PFOA-induced testicular toxicity. Wild-type, PPAR α -null, and humanized PPAR α male 129/Sv mice were given PFOA daily by gavage at doses of 0, 1, and 5 mg/kg/day for 6 weeks. Body weight and testis weight were not affected by treatment in any group. Absolute and relative-to-body weights of the epididymis and seminal vesicle plus prostate gland were decreased only in high-dose wild-type

mice compared to the wild-type controls. No effects on sperm count and motility were seen in any group. Sperm abnormalities were significantly increased in both treated groups of wild-type and humanized PPAR α mice, but not in the PPAR α -null mice. Plasma testosterone levels were slightly decreased in low-dose wild-type mice, and significantly decreased in high-dose wild-type and low- and high-dose humanized PPAR α mice compared to the control groups. Testosterone levels were slightly reduced in a dose-related manner in the PPAR α -null mice, but statistical significance was not attained.

Using real-time quantitative PCR, the mRNA levels for several genes associated with testicular cholesterol synthesis, transport, and testosterone biosynthesis were examined. Levels of 3-hydroxy-3-methylglutaryl coenzyme A (HMG-CoA) synthase, HMG-CoA reductase, and aromatase were not changed after treatment in any group. Expression of steriodogenic acute regulatory protein (which transports cholesterol into mitochondria) was inhibited in wild-type mice at the high dose and in humanized PPAR α mice at both doses; peripheral benzodiazepine receptor level was decreased only in high-dose humanized PPAR α mice; cytochrome P450 side-chain cleavage enzyme was decreased in both groups of wild-type mice; cytochrome P450 17 α -hydroxylase/C17-20 lyase was inhibited at the high dose in both wild-type and humanized PPAR α mice; and 3 β -hydroxysteroid dehydrogenase was decreased in both treated groups of humanized PPAR α mice. Decreased expression of 17 β -hydroxysteroid dehydrogenase was the only change found in treated PPAR α -null mice.

In the mitochondria, carnitine palmitoyltransferase (CPT) was decreased in both groups of wild-type and high-dose humanized PPAR α mice, and SOD levels were reduced in all treated wild-type and humanized PPAR α mice. Histopathological lesions of the testes, including abnormal seminiferous tubules, lack of germ cells, or necrotic cells, were observed in high-dose wild-type and humanized PPAR α mice. No morphological changes were observed in the testes from PFOA treatment in PPAR α -null mice. The 1-mg/kg/day dose was the LOAEL for significant ($p < 0.05$) sperm abnormalities, decreased testosterone, and several biochemical alterations in the PPAR α and hPPAR α mice, but not in the PPAR α -null mice. There were dose-related decreases in testosterone in the PPAR α -null mice, but they did not achieve statistical significance.

Inhalation Exposure

No data on the effects of short-term inhalation exposures to PFOA were identified in the literature.

Dermal Exposure

Fairley et al. (2007) investigated the role of dermal exposure to PFOA in an experiment to evaluate toxicity in BALB/c mice. The mice were exposed to 0, 0.01%, 0.1%, 0.25%, 0.5%, 1.0%, and 1.5% PFOA (equivalent to 0, 0.25, 2.5, 6.25, 12.5, 25, and 50 mg/kg PFOA). It was applied to the dorsal surface of both ears daily for 4 days. The mice were sacrificed 6 days later. Dermal PFOA exposure did not cause reductions in body weight or signs of inflammation at the application site. A significant increase in liver weight was observed in mice dosed with ≥ 6.25 mg/kg PFOA ($p < 0.01$) compared to control liver weight. Under the conditions of the study, the LOAEL was 6.25 mg/kg PFOA based on increased liver weight, and the NOAEL was 2.25 mg/kg PFOA.

3.2.3 Subchronic Studies

Oral Exposure

Monkey. Goldenthal (1978) administered rhesus monkeys (two per gender per group) doses of 0, 3, 10, 30, and 100 mg/kg/day PFOA by gavage for 90 days. Animals were observed twice daily and body weights were recorded weekly. Blood and urine samples were collected once during a control period, and at 1 and 3 months for hematology, clinical chemistry, and urinalysis. Organs and tissues from animals that were sacrificed at the end of the study and from animals that died during the treatment period were weighed, examined for gross pathology, and processed for histopathology.

All monkeys in the 100-mg/kg/day group died between weeks 2–5 of the study. Signs and symptoms that first appeared during week 1 included anorexia, frothy emesis, swollen face and eyes, decreased activity, prostration, and body trembling. Three monkeys from the 30-mg/kg/day group died during the study. Beginning in week 4, all four animals showed slight to moderate, and sometimes severe, decreased activity. One monkey had emesis and ataxia, swollen face, eyes, and vulva. Beginning in week 6, two monkeys had black stools and one monkey had slight-to-moderate dehydration. No monkeys in the 3- or 10-mg/kg/day groups died during the study. One monkey in the 10-mg/kg/day group was anorexic during week 4, had a pale and swollen face in week 7, and had black stools for several days in week 12. Animals in the 3-mg/kg/day group occasionally had soft stools or moderate-to-marked diarrhea and frothy emesis.

Changes in body weight were similar to the controls for animals from the 3- and 10-mg/kg/day groups. Monkeys from the 30- and 100-mg/kg/day groups lost body weight after week 1. At the end of the study, this loss was statistically significant for the one surviving male in the 30-mg/kg/day group and reflected in body weight (2.30 kg versus 3.78 kg for the control). The results of the urinalysis, and hematological and clinical chemistry analyses were comparable for the control and the 3- and 10-mg/kg/day groups at 1 and 3 months.

At necropsy, there were significant decreases in the absolute heart and brain weight and relative liver weight in 10-mg/kg/day females. At 3 mg/kg/day, the relative pituitary weight in males was significantly increased. The biological significance of these weight changes is difficult to assess, as they were not accompanied by morphologic changes.

In animals that died, one male and two females from the 30-mg/kg/day group and all animals from the 100-mg/kg/day group had marked diffuse lipid depletion in the adrenal glands. All males and females from the 30- and 100-mg/kg/day groups also had slight to moderate hypocellularity of the bone marrow and moderate atrophy of lymphoid follicles in the spleen. One female from the 30-mg/kg/day group and all animals in the 100-mg/kg/day group had moderate atrophy of the lymphoid follicles in the lymph nodes.

The one male in the 30-mg/kg/day group that survived until terminal sacrifice had slight-to-moderate hypocellularity of the bone marrow and moderate atrophy of lymphoid follicles in the spleen. Under the conditions of this study, the male LOAEL was 3 mg/kg/day based on increased relative pituitary weight, and no NOAEL was established. The female LOAEL was 10 mg/kg/day based on decreased heart and brain weight, and the NOAEL was 3 mg/kg/day.

Rat. In a dietary study reported by Perkins et al. (2004), male ChR-CD rats (45–55 per group) were administered concentrations of 1, 10, 30, and 100 ppm PFOA for 13 weeks. These doses are equivalent to 0.06, 0.64, 1.94, and 6.50 mg/kg/day. There were two control groups—a nonpair-fed control group and a pair-fed control group for the 100-ppm dose group); both were fed the basal diet. Following the 13-week exposure period, 10 animals per group were fed basal diet for an 8-week recovery period. The animals were observed twice daily for clinical signs of toxicity, and body weights and food consumption were recorded weekly. Food consumption was recorded daily for the pair-fed animals.

A total of 15 animals per group were sacrificed following 4, 7, and 13 weeks of treatment; 10 animals per group were sacrificed after 13 weeks of treatment and an 8-week recovery period. Serum samples collected from 10 animals per group at each scheduled sacrifice during treatment and from five animals per group during recovery were analyzed for estradiol, T, LH, and PFOA. The level of palmitoyl-CoA oxidase was analyzed from a section of liver that was obtained from five animals per group at each scheduled sacrifice. Weights of the brain, liver, lungs, testis, seminal vesicle, prostate, coagulating gland, and urethra were recorded, and these tissues also were examined histologically. In addition, the brain, liver, lungs, testis, seminal vesicle, and prostate were preserved in glutaraldehyde for electron microscopic examination.

In the analysis of the data, animals exposed to 1, 10, 30, and 100 ppm PFOA were compared to the control animals in the nonpair-fed group, while the data from the pair-fed control animals were compared to animals exposed to 100 ppm PFOA. At 100 ppm, significant reductions in body weight and body weight gain were seen compared to the pair-fed control group during week 1 and the nonpair-fed control group during weeks 1–13. Body weight data in the other dosed groups were comparable to controls. At 10 and 30 ppm, mean body weight gains were significantly lower than for the nonpair-fed control group at week 2. These differences in body weight and body weight gains were not observed during the recovery period. Animals fed 100 ppm consumed significantly less food during weeks 1 and 2 than the nonpair-fed control group. Overall, there was no significant difference in food consumption. There were no significant differences among the groups for any of the hormones evaluated, although there was some indication of elevated estradiol for the 100 ppm group at week 4. The elevated estradiol for the high-dose group at week 4 should be interpreted with caution because most of the measurements for control and treated groups were below the level of detection at all other timepoints (Perkins et al. 2004).

Significant dose-related increases in absolute and relative liver weights and hepatocellular hypertrophy were observed at weeks 4, 7, and 13 in the 10, 30, and 100 ppm groups (Table 3-18). There was no significant evidence of any dose-related degenerative changes. Hepatic palmitoyl-CoA oxidase activity was significantly increased at weeks 4, 7, and 13 in the 30 and 100 ppm groups. At 10 ppm, hepatic palmitoyl-CoA oxidase activity was significantly increased at week 4 only. At 13 weeks, the palmitoyl-CoA oxidase activity was lower than it was at weeks 4 and 7 for the 10, 30, and 100 ppm dose groups, possibly suggesting attenuation of the peroxisomal response. Histologically, liver effects were limited to minimal or slight coagulative necrosis observed in 0/45, 1/45, 0/45, 2/45, and 3/44 in the control, 1, 10, 30, and 100 ppm groups, respectively.

Table 3-18. Liver Effects in Male Rats

Parameter	Week	Dose (mg/kg/day)					
		0 ^a	0 ^b	0.06 (1 ppm)	0.64 (10 ppm)	1.94 (30 ppm)	6.5 (100 ppm)
Palmitoyl-CoA Oxidase (IU/g)	4	8 ± 0.5	8 ± 0.4	9 ± 1.7	14 ± 3.6 ^c	24 ± 11.4 ^c	37 ± 14.8 ^{c,d}
	7	7 ± 1.5	7 ± 1.5	7 ± 0.8	16 ± 5.5	32 ± 12.2 ^c	54 ± 35.3 ^{c,d}
	13	8 ± 0.9	5 ± 1.1	8 ± 1.9	10 ± 2.1	14 ± 3.4 ^c	17 ± 4.5 ^{cd}
Hepatocellular Hypertrophy	4	0/15	0/15	0/15	12/15	15/15	14/15
	7	0/15	0/15	0/15	12/15	15/15	15/15
	13	0/15	0/15	0/15	13/15	14/15	15/15
Hepatocellular Necrosis, Coagulative	4	0/15	1/15	0/15	0/15	1/15	2/14
	7	0/15	0/15	0/15	0/15	0/15	1/15
	13	0/15	0/15	1/15	0/15	1/15	0/15
Absolute Liver Weight (g)	4	16.34 ± 2.14	15.83 ± 1.13	15.45 ± 1.71	17.89 ± 2.13	23.23 ± 2.83 ^c	25.44 ± 1.89 ^c
	7	17.78 ± 2.12	16.91 ± 2.22	17.68 ± NA	19.42 ± 2.10	27.76 ± 3.51 ^c	27.76 ± 3.51 ^c
	13	19.73 ± 2.01	16.30 ± 1.62	18.03 ± 2.81	20.44 ± 2.87	22.74 ± 4.21	26.78 ± 5.47 ^c
Mean Body Weight (g)	4	388 ± 21	365 ± 11	388 ± 23	383 ± 25	380 ± 27	356 ± 27 ^c
	7	457 ± 29	434 ± 19	461 ± 30	458 ± 30	448 ± 31	432 ± 39 ^c
	13	541 ± 41	508 ± 22	548 ± 37	551 ± 42	531 ± 46	494 ± 64 ^c
Liver/Body Weight (%)	4	3.97 ± 0.37	4.07 ± 0.27	3.73 ± 0.23	4.49 ± 0.32 ^c	5.77 ± 0.60 ^c	6.73 ± 0.49 ^c
	7	3.75 ± 0.29	3.76 ± 0.37	3.64 ± 0.33	4.12 ± 0.37	5.14 ± 0.53 ^c	6.06 ± 0.72 ^c
	13	3.53 ± 0.28	3.24 ± 0.23	3.24 ± 0.30 ^c	3.69 ± 0.32	4.21 ± 0.56 ^c	5.50 ± 0.84 ^c

Source: Perkins et al. 2004

Notes: Mean ± SD; NA= not available.

^a Nonpair-fed controls.

^b Pair-fed controls.

^c Statistically significant (p < 0.05) with nonpair-fed control.

^d Statistically significant (p < 0.05) with pair-fed control.

Under the conditions of this study, the authors identified the LOAEL as 10 ppm (0.64 mg/kg/day) based on increases in absolute and relative liver weight and hepatocellular hypertrophy (Perkins et al. 2004). The NOAEL identified was 1.0 ppm (0.06 mg/kg/day). However, the liver weight and palmitoyl-CoA responses were associated with the activation of PPAR α and were not accompanied by significant dose-related changes that would classify them as adverse for humans (e.g., fibrosis, macrovesicular steatosis, inflammation) as enumerated by Hall et al. (2012). Therefore, for the current assessment, the LOAEL is identified as 1.94 mg/kg/day based on a slight increased incidence of coagulative necrosis in the liver. The NOAEL is 0.64 mg/kg/day.

Serum samples were collected from 8 to 10 animals prior to each sacrifice. PFOA concentrations in serum increased with the dose, but all dose levels appeared to have reached steady state by the first sacrifice at week 4. Following the 8-week recovery period, serum levels were below detection for many animals and consistent with a half-life of about seven days in male ChR-CD rats.

Inhalation and Dermal Exposure

No data on the effects of subchronic inhalation or dermal exposures to PFOA were identified in the literature.

3.2.4 Neurotoxicity

Johansson et al. (2008) gave male neonatal Naval Medical Research Institute (NMRI) mice (3–4 litters, ~5–6 male pups per litter) a single gavage dose of 0, 0.58, and 8.7 mg PFOA/kg in a lecithin/peanut oil emulsion on PND 10, the approximate peak time of rapid brain growth in mice. Spontaneous behavior (e.g., locomotion, rearing, and total activity) and habituation in response to a placement in unfamiliar environment were tested in 10 mice in each group at ages 2 and 4 months. Each test period was divided into three 20-min periods. The habituation ratio was determined by dividing the activity for the third 20-min period by the activity for the first period. A high habituation ratio indicated that movement patterns of the exposed animals when placed in an unfamiliar test chamber differed from control by displaying comparatively low activity for the first 20 mins and comparatively higher activity for the last 20 mins.

Exposure to PFOA did not affect body weight or body weight gain in male NMRI mice following treatment. Compared to controls, the habituation ratio for rearing and locomotion in the high-dose animals was elevated compared to controls at 2 and 4 months, with a significantly higher ratio ($p < 0.01$) at 4 months than at 2 months. At 4 months, the changes in activity patterns for the high dose were significant ($p < 0.01$) compared to controls for locomotion, rearing, and total activity. The results at the low dose were less pronounced, with a significant impact on locomotion and slight changes in rearing behavior.

At 4 months of age, mice were tested for nicotine-induced behavior and behavior in the elevated plus maze. Increased activity is the expected response to nicotine injection (80 μg) as a result of stimulation of the cholinergic receptors in the brain. The activity responses of the PFOA-exposed animals to nicotine stimulation were significantly less than the response of the controls, but the differences were most pronounced in the high-dose animals.

The mice also were tested in an elevated plus maze, which determined whether they would select an enclosed environment (the expected response) over an open environment. No significant differences were observed in the PFOA-exposed mice in this test. Under the conditions of this study, the clear LOAEL was 8.7 mg/kg based on locomotion, rearing, and total activity; habituation ratio; and response to nicotine at 2 and 4 months after receiving a single gavage dose on PND 10. There were significant differences in locomotion and total activity at 4 months in the low-dose animals, which supports identifying the 0.58-mg/kg dose as a marginal LOAEL. However, the data at the low dose are less compelling than those at the high dose.

In a follow-up to their original study, Johansson et al. (2009) gave male neonatal NMRI mice (3–4 litters, ~5–6 male pups per litter) a single gavage dose of 0 and 8.7 mg PFOA/kg on PND 10. Protein levels of calcium/calmodulin-dependent protein kinase II (CaMKII), growth-associated protein-43 (GAP-43), synaptophysin, and tau protein were determined in the cerebral cortex and hippocampus. CaMKII regulates synaptogenesis and synaptic plasticity, GAP-43 modulates axon sprouting and growth, synaptophysin is a membrane glycoprotein in presynaptic vesicles, and tau protein is responsible for outgrowth of neuronal processes and microtubule assembly and maintenance.

Levels of CaMKII protein in the hippocampus were significantly higher (58%, $p \leq 0.05$) in mice exposed to PFOA than levels in control mice, but unchanged in the cerebral cortex. Levels of GAP-43 protein in the hippocampus were significantly higher (17%, $p \leq 0.05$) in PFOA-exposed mice than levels in control mice, but unchanged in the cerebral cortex. Synaptophysin levels in mice exposed to PFOA were significantly increased in the hippocampus (52%) and

cerebral cortex (82%). Tau protein levels in PFOA-exposed mice were increased 92% and 142% ($p \leq 0.001$) in the hippocampus and cerebral cortex, respectively, above levels in the control mice. The authors concluded that alterations of these proteins could be a factor in the altered behavior of adult mice that were exposed to PFOA as neonates because they are required for normal brain development.

Onishchenko et al. (2011) exposed pregnant C57BL/6/Bkl mice ($n = 6$ per group) to 0 and 0.3 mg PFOA/kg/day in the diet from GD 1 to the end of pregnancy. The behavior of the weaned offspring was analyzed in locomotor, circadian activity, elevated plus maze, and forced swim tests at 5–8 weeks of age. Muscle strength and motor coordination tests were given at 3–4 months of age. The distance traveled over 30 mins was registered in 5-min intervals in the locomotor test. For the circadian activity test, the activity of the mice in social groups was monitored for 48 hours after placement in new cages. Anxiety-like behavior was determined using the elevated plus maze. Depression-like behavior was determined in the forced swim test by tracking the time spent floating passively for 2 seconds or longer. Muscle strength (three trials) was measured by how long within 60 seconds it took the mouse to fall off an upside-down lid onto the cage floor. Motor coordination (four trials) was measured by how long the mice remained on a rotating drum as a rotarod accelerated from 4 to 40 rpm over 5 mins.

Prenatal exposure to PFOA did not alter offspring locomotor activity, anxiety-related behavior, depression-like behavior, or muscle strength. In the circadian activity tests, male offspring exposed to PFOA were significantly more active ($p = 0.013$) and the female offspring were significantly less active ($p = 0.036$) than control offspring during the first hour of the test. PFOA-exposed male offspring were significantly more active ($p < 0.05$) than control males from the dark phase of day 1 through the dark phase day 2. Both male and female offspring exposed to PFOA had significantly less inactive periods ($p < 0.05$) during the light phase compared to their respective controls. In the accelerating rotarod test, female offspring exposed to PFOA exhibited decreased fall latency over the four trials compared to control females, but no effect of treatment was observed in male offspring. The authors concluded that prenatal exposure to 0.3 mg/kg/day of PFOA resulted in gender-related postnatal alterations in offspring behavior and motor function at 3–4 months of age.

In vitro. Slotkin et al. (2008) characterized the neurotoxicity of PFOA using PC12 cells. The cells were derived from a neuroendocrine tumor of the rat adrenal medulla and serve as a model for neuronal development and differentiation. Exposure to nerve growth factors causes PC12 cells to differentiate into cells expressing either dopamine or acetylcholine phenotypes. The cells were incubated with 10, 50, 100, and 250 μmol PFOA. Synthesis of DNA, cell viability, cell growth, and lipid peroxidation were measured to determine if PFOA targets specific events in neural cell differentiation. Differentiation shifts towards or away from the dopamine and acetylcholine phenotypes were measured by assessing the activities of tyrosine hydroxylase (TH, dopamine) and choline acetyltransferase (ChAT, acetylcholine). The undifferentiated cells were evaluated after a 24-hour exposure to PFOA, and differentiating cells were evaluated after 4–6 days of exposure to PFOA.

Significant inhibition of DNA synthesis ($p < 0.0001$) occurred in the undifferentiated cells after exposure to 250 μmol PFOA with no change in DNA content. Lipid peroxidation was significantly increased ($p < 0.02$) after exposure to 10 μmol PFOA, and cell viability was significantly decreased ($p < 0.03$) after a 24-hour exposure to 100 and 250 μmol PFOA.

In differentiating PC12 cells, exposure to 250 μmol PFOA caused decreased DNA content with no change in total protein/DNA content ratio or the membrane/total protein ratio. The lowest and highest PFOA concentrations caused a significant increase in lipid peroxidation ($p < 0.007$), but no effect was observed in cell viability. TH activity was decreased ($p < 0.05$) after exposure to 10 and 250 μmol PFOA, and the TH/ChAT ratio was decreased ($p < 0.05$) at 10 μmol PFOA. The results suggest that PFOA exposure caused the differentiating cells to shift slightly to favor the acetylcholine phenotype.

3.2.5 Developmental/Reproductive Toxicity

Reproductive Effects

A comprehensive two-generation reproductive toxicity study was conducted in Sprague-Dawley Rats with publication of the results by Butenhoff et al. (2004a). A subsequent study by York et al. (2010) provided details of male reproductive organ histopathology. One study in mice examined the impact of mating exposed males with unexposed females on fertility and neonatal body weight (Lu et al. 2015).

Rat. A standard oral two-generation reproductive toxicity study of PFOA in Sprague-Dawley rats was conducted (Butenhoff et al. 2004a). Five groups of male and female SD rats (30 per gender per group) were administered PFOA by gavage at doses of 0, 1, 3, 10, and 30 mg/kg/day. The parental generation (F0) rats ($n = 30$ per gender per group) were dosed for 10 weeks prior to mating and until sacrificed (after mating for males; after weaning for females). F1 generation rats ($n = 60$ per gender per group) were dosed similarly, beginning at weaning. The F2 generation rats were maintained through LD 22. Reproductive parameters evaluated in the F0 and F1 generations included estrus cyclicity, sperm number and quality, mating, fertility, natural delivery, and litter viability and growth. Age at sexual maturation in F1 pups, anogenital distance in F2 pups, and presence of nipples (males) in F2 pups also were determined. Food consumption, body-weight gain, selected organ weights, gross pathology, and appropriate histopathology of reproductive organs were evaluated.

F0 Male Rats

One F0 male rat in the 30 mg/kg/day dose group was sacrificed on day 45 of the study because of adverse clinical signs. Statistically significant increases in clinical signs also were observed in male rats in the high-dose group, including dehydration, urine-stained abdominal fur, and ungroomed coat. Significant reductions in body weight were reported beginning on post-weaning day 50 at 3 mg/kg/day and for most of the study until termination in 10 and 30 mg/kg/day dose groups (6%, 11%, and 25% decrease from controls, respectively, at the end of pre-mating; $p \leq 0.05$). Absolute food consumption was significantly reduced to approximately 91% of the control level during the study in the 30-mg/kg/day dose group but not for the lower dose groups. Mean food consumption relative to body weight was increased in a dose-related manner for all treated males with statistical significance at ≥ 3 mg/kg/day; overall relative food consumption was 101, 105, 110, and 118% of the controls in the 1, 3, 10, and 30 mg/kg/day groups, respectively. The body weight and food consumption effects were not observed in female rats at any dose.

Organ weight data for the F0 male rats is shown in Table 3-19. The absolute and relative-to-body and -brain weights of the liver were statistically significantly increased in all dose groups. Absolute kidney weights were statistically significantly increased in the 1-, 3-, and 10-mg/kg/day dose groups, but significantly decreased in the 30-mg/kg/day group. Organ weight-to-terminal body weight ratios for the left and right kidney were statistically significantly increased in all treated groups. Kidney weight-to-brain weight ratios were significantly increased at 1, 3, and 10 mg/kg/day, but decreased at 30 mg/kg/day, following the trends in absolute weights. In the high-dose group, absolute and relative kidney weight changes occurred in a pattern typically associated with decrements in body weight. However, in the lower dose groups, consistent significant increases in absolute kidney weight and relative-to-body and -brain weights are a response to the challenge of providing transporters for renal removal of the foreign molecule. Increased kidney weight can be regarded as an adaptive response to the transport challenge. It is beneficial for the individual but adverse in the sense that it signifies the need to upregulate tubular transporters in the kidney to excrete the foreign material and a reflection of PFOA bioaccumulation in serum and tissues.

Table 3-19. Organ Weight Data from F0 Male Rats

	0 mg/kg/day	1 mg/kg/day	3 mg/kg/day	10 mg/kg/day	30 mg/kg/day
Body weight (g)	581 ± 40	575 ± 48	542 ± 47**	513 ± 54**	432 ± 64**
Brain weight (g)	2.26 ± 0.17	2.28 ± 0.10	2.26 ± 0.12	2.24 ± 0.12	2.20 ± 0.14
Liver weight (g)	20.3 ± 2.5	24.3 ± 3.2**	27.7 ± 2.7**	28.7 ± 3.9**	27.5 ± 3.7**
Liver/body (%)	3.49 ± 0.29	4.22 ± 0.50**	5.13 ± 0.47**	5.61 ± 0.51**	6.42 ± 0.73**
Liver/brain (%)	903 ± 119	1066 ± 154**	1230 ± 120**	1285 ± 183**	1248 ± 144**
Rt. kidney (g)	2.19 ± 0.18	2.54 ± 0.30**	2.50 ± 0.18**	2.36 ± 0.25**	2.06 ± 0.20*
Rt. kidney/body (%)	0.379 ± 0.030	0.443 ± 0.048**	0.463 ± 0.039**	0.462 ± 0.034**	0.481 ± 0.051**
Rt. kidney/brain (%)	97.5 ± 9.9	111.6 ± 13.5**	111.0 ± 9.5**	105.6 ± 12.4**	93.5 ± 8.7
Lt. kidney (g)	2.19 ± 0.20	2.51 ± 0.28**	2.51 ± 0.21**	2.34 ± 0.24*	1.99 ± 0.19**
Lt. kidney/body (%)	0.378 ± 0.036	0.437 ± 0.047**	0.465 ± 0.043**	0.457 ± 0.040**	0.466 ± 0.054**
Lt. kidney/brain (%)	97.5 ± 10.7	110.1 ± 12.6**	111.7 ± 10.5**	104.6 ± 11.7*	90.4 ± 8.7*

Source: Butenhoff et al. 2004a

Notes: Mean±SD; n = 29–30; significantly different from control: *p < 0.05, **p < 0.01.

The only histologic finding was increased thickness and prominence of the zona glomerulosa and vacuolation in the cells of the adrenal cortex observed in 2/10 males in the 10-mg/kg/day dose group and 7/10 males in the 30-mg/kg/day dose group.

No treatment-related effects were reported at any dose level for any of the male reproductive parameters assessed. There was no evidence of altered testicular and sperm structure and function in PFOA-treated F0 rats with mean group serum PFOA concentrations of up to approximately 45 µg/mL (York et al. 2010). There was a significant dose-related increase in seminal vesicle weight (p<0.05) with and without fluid in the F1 males, but fertility of the exposed males in all generations was comparable to the controls.

No treatment-related effects were seen at necropsy or upon microscopic examination of the reproductive organs.

Under the conditions of the study, the LOAEL for F0 parental male rats is 1 mg/kg/day, the lowest dose tested, based on significant increases in absolute and relative liver and kidney weights. A NOAEL for the F0 parental males could not be determined.

F0 Female Rats

There were no treatment-related effects on clinical signs, body weight, food consumption, organ weights, or histology of the organs. There were no treatment-related effects on any of the reproductive parameters assessed, and no treatment-related effects were seen at necropsy other than slightly decreased liver weights ($p < 0.05$) at doses of 3 and 10 mg/kg/day, but not 30 mg/kg/day. No abnormalities were seen with microscopic examination of the reproductive organs. The NOAEL for F0 parental females is 30 mg/kg/day, the highest dose tested.

F1 Generation

Pup body weight on a per-litter basis (genders combined) was significantly reduced ($p \leq 0.01$) by 8–10% throughout the first 2 weeks of lactation in the 30-mg/kg/day group; at weaning, the mean body weight was reduced 4.5%, but the difference was not statistically significant. Although there were no effects on the viability and lactation indices, the total number of dead pups during lactation was increased in the 30-mg/kg/day groups; the difference was statistically significant on LDs 6–8. No other effects were noted, and there were no treatment-related findings for the pups necropsied at weaning. The offspring toxicity LOAEL is 30 mg/kg/day based on decreased body weight and an increase in the number of dead pups; the NOAEL is 10 mg/kg/day.

F1 Male Rats

Significant increases in treatment-related deaths (5/60 animals) were reported in F1 males in the high-dose group between days 2–4 postweaning. One rat was moribund sacrificed on day 39 postweaning and another was found dead on day 107 postweaning. Clinical signs included a significant increase in emaciation at 10 and 30 mg/kg/day, and in urine-stained abdominal fur, decreased motor activity, and abdominal distention at 30 mg/kg/day.

Mean body weight was significantly reduced in the 30-mg/kg/day group beginning on postweaning day 8, in the 10-mg/kg/day group beginning on postweaning day 36, and towards the end of the study in the 1- and 3-mg/kg/day groups. Terminal mean body weight was reduced in all treated groups at the time of sacrifice. For all groups, there was a significant, dose-related reduction in mean body weight gain for the entire dosing period (days 1–113). Absolute food consumption values were significantly reduced at 10 and 30 mg/kg/day during the entire precohabitation period (days 1–70 postweaning), while relative food consumption values were significantly increased.

Statistically significant delays in the average day of preputial separation ($p \leq 0.01$) were observed in high-dose animals versus concurrent controls (52.2 days of age versus 48.5 days of age, respectively). There were no other effects on any of the reproductive parameters assessed, and at necropsy no effects on reproductive organs or fertility were noted (York et al. 2010).

The absolute and relative weights of the liver were statistically significantly increased in all treated groups ($p \leq 0.01$). Treatment-related microscopic changes were described as diffuse hepatocellular hypertrophy in rats receiving doses of ≥ 3 mg/kg/day. At the same dose levels, there were scattered incidences of focal-to-multifocal necrosis and inflammation in the livers of the F1 male rats. As in the F0 males, the relative weight of the left and/or right kidneys was statistically significantly increased compared to controls for all dose groups, except for the right kidney at the high dose in which it was lower than for the controls (Table 3-20). Organ weight-to-terminal body weight and brain weight ratios for the kidney were statistically significantly

increased in all treated groups. All other organ weight changes observed (i.e., thymus, spleen, left adrenal, brain, prostate, seminal vesicles, testes, and epididymis) were probably due to decrements in body weight and not a reflection of target organ toxicity. Treatment-related microscopic changes were observed in the adrenal glands of high-dose animals (i.e., cytoplasmic hypertrophy and vacuolation of the cells of the adrenal cortex) and in the liver of rats treated with 3, 10, and 30 mg/kg/day (hepatocellular hypertrophy).

Table 3-20. Organ Weight Data from F1 Male Rats

	0 mg/kg/day	1 mg/kg/day	3 mg/kg/day	10 mg/kg/day	30 mg/kg/day
Body weight (g)	560 ± 60	527 ± 55*	524 ± 48*	499 ± 64**	438 ± 42**
Brain weight (g)	2.34 ± 0.13	2.28 ± 0.16	2.31 ± 0.12	2.28 ± 0.10	2.18 ± 0.14**
Liver weight (g)	21.7 ± 3.2	24.6 ± 4.0**	28.2 ± 4.2**	29.3 ± 4.1**	29.7 ± 4.0**
Liver/body (%)	3.86 ± 0.32	4.65 ± 0.51**	5.41 ± 0.75**	5.90 ± 0.70**	6.79 ± 0.55**
Liver/brain (%)	927 ± 136	1075 ± 150**	1224 ± 179**	1285 ± 159**	1364 ± 166**
Rt. kidney (g)	2.24 ± 0.21	2.34 ± 0.28	2.48 ± 0.24**	2.33 ± 0.25	2.04 ± 0.21**
Rt. kidney/body (%)	0.402 ± 0.034	0.446 ± 0.041**	0.474 ± 0.041**	0.469 ± 0.050**	0.467 ± 0.036**
Rt. kidney/brain (%)	95.9 ± 9.1	102.6 ± 7.7**	107.4 ± 10.2**	102.3 ± 9.8*	93.6 ± 7.9
Lt. kidney (g)	2.21 ± 0.20	2.35 ± 0.26*	2.46 ± 0.20**	2.30 ± 0.22	2.03 ± 0.22**
Lt. kidney/body (%)	0.396 ± 0.031	0.446 ± 0.042**	0.472 ± 0.045**	0.464 ± 0.046**	0.465 ± 0.038**
Lt. kidney/brain (%)	94.8 ± 7.9	102.8 ± 7.6**	106.6 ± 9.1**	101.0 ± 7.9*	93.3 ± 10.0

Source: Butenhoff et al. 2004a

Notes: Mean±SD; n = 29-30; significantly different from control: *p<0.05, **p<0.01.

The LOAEL for adult systemic toxicity in the F1 males is 1 mg/kg/day based on significant, dose-related decreases in body weights and body weight gains, and in terminal body weights; and significant increases in absolute and relative kidney weights. A NOAEL for adult systemic toxicity in the F1 males could not be determined. Liver weights were significantly increased at all doses, but only accompanied by microscopic lesions at doses ≥ 3 mg/kg/day.

F1 Female Rats

A statistically significant increase in treatment-related mortality (6/60 animals) was observed in F1 females on postweaning days 2–8 at the highest dose of 30 mg/kg/day. No adverse clinical signs of treatment-related toxicity were reported. Statistically significant decreases in body weight were observed in high-dose rats on days 8, 15, 22, 29, 50, and 57 postweaning, during precohabitation (recorded on the day cohabitation began, when F1 generation rats were 92–106 days of age), and during gestation and lactation. Body weight gain was significantly reduced during days 1–8 and 8–15 postweaning. Statistically significant decreases in absolute food consumption were observed during days 1–8, 8–15, and 15–22 postweaning, during precohabitation, and during gestation and lactation in animals treated with 30 mg/kg/day. Relative food consumption values were comparable across all treated groups.

Statistically significant delays (p≤0.01) in sexual maturation (the average day of vaginal patency) were observed in high-dose animals versus concurrent controls (36.6 days of age versus 34.9 days of age, respectively). Prior to the rats mating, the study authors noted a statistically significant increase in the average numbers of estrous stages per 21 days in high-dose animals (5.4 versus 4.7 in controls). For this calculation, the number of independent occurrences of estrus in the 21 days of observation was determined. This calculation can be used as a screen for effects on the estrous cycle, but should be followed by a more detailed analysis.

Both 3M (2002, cited in USEPA [2005c]), and EPA (USEPA 2002b) conducted a more detailed analysis of the estrous cycle data. The 3M analysis of the data concluded that there were no differences in the number of females with ≥ 3 days of estrus or with ≥ 4 days of diestrus in the control and high-dose groups. This conclusion is consistent with that of EPA (USEPA 2002b). The cycles were evaluated as having either regular 4–5-day cycles, uneven cycling (defined as brief periods with irregular pattern) or periods of prolonged diestrus (defined as 4–6-day diestrus periods), extended estrus (defined as 3–4 days of cornified smears), possible pseudopregnancy (defined as 6 or more days of leukocytes), or persistent estrus (defined as 5 or more days of cornified smears). The two groups were not different in any of the parameters measured. Thus, the increase in the number of estrus stages per 21 days noted by the study authors was an outcome of the approach used for the calculations and is not biologically meaningful. There were no effects on the other reproductive parameters assessed, and at necropsy no effects on reproductive organs were noted.

No treatment-related effects were observed in the terminal body weights of the F1 female rats. The absolute weight of the pituitary, the pituitary weight-to-terminal body weight ratio, and the pituitary weight-to-brain weight ratio were statistically significantly decreased at 3 mg/kg/day and higher. Since there is not a clear dose-response relationship and histologic examination reveal no lesions, the biological significance of the pituitary weight data is problematic. No other differences were reported for the absolute weights or ratios for other organs evaluated. No treatment-related effects were reported following macroscopic and histopathologic examinations.

For F1 females, the LOAEL for developmental/reproductive toxicity was considered to be 30 mg/kg/day based on significantly reduced body weight and body weight gain during lactation, a delay in sexual maturation, and increased mortality during postweaning days 2–8; the NOAEL was 10 mg/kg/day. The NOAEL and LOAEL for adult systemic toxicity in F1 females are 10 and 30 mg/kg/day, respectively, based on statistically significant decreases in body weight and body weight gains.

F2 Generation Rats

There was a statistically significant increase ($p \leq 0.01$) in the number of pups found dead on LD 1 in the 3- and 10-mg/kg/day groups. An independent statistical analysis was conducted by EPA (USEPA 2002c), and no significant differences were observed between dose groups and the response did not have any trend in dose. There were no treatment-related effects on any of the developmental parameters assessed, and at necropsy, no treatment-related effects were noted. The NOAEL for developmental/reproductive toxicity in the F2 offspring was 30 mg/kg/day.

Mouse. In a follow-up to the 28-day component of the Lu et al. study (2015) of the impact on PFOA on the blood testes barrier (section 3.2.2), the authors examined the impact exposure to 0 and 5 mg/kg/day PFOA had on the fertility of the treated male mice (6–8 weeks old; 15 per dose group). Each treated male was mated with three virgin ICR females (8–10 weeks old). Successful mating was determined by the presence of a vaginal plug in the morning. The pregnant females were separated from the males and caged alone throughout the pregnancy; they were not dosed with PFOA. At parturition, the pups were counted and the litter body weight recorded. There was a statistically significant decrease in the number of mated females per male mouse and pregnant females per male mouse ($p < 0.001$) for the exposed males compared to the controls. The average number of pups per litter was smaller for the exposed group (10.20 ± 0.72 versus 11.89 ± 0.54), but the difference was not significant. The average litter weight was

significantly lower for the offspring of the paternally exposed mice than of the paternal controls (16.17 ± 1.63 g versus 19.95 ± 0.80 g; $p < 0.05$). The 5-mg/kg/day dose was a LOAEL for effects on male fertility and the significantly lower body weight of their progeny.

Developmental Effects

Standard developmental studies in rats and mice found impacts on pup body weight and developmental delays. Most studies used the oral route of exposure; one study used inhalation exposure to PFOA particulate matter. Some examined the developmental impact of PFOA associated with exposures that occurred only during gestation and lactation or during the prepubertal period and the association of PPAR α with the developmental effect spectrum. A substantial number of studies in mice focused on PFOA's impact on mammary gland development.

3.2.6 Prenatal Development

Rat. Pregnant Sprague-Dawley rats were gavage-dosed with 0, 3, 10, and 30 mg/kg/day PFOA during days 4–10, 4–15, and 4–21 of gestation, or from GD 4 to LD 21 (Hinderliter et al. 2005; Mylchreest 2003). Clinical observations and body weights were recorded daily. On GDs 10, 15, and 21, five rats per group per time-point were sacrificed and the number, location, and type of implantation sites were recorded. Embryos were collected on day 10, and placentas, amniotic fluid, and embryos/fetuses were collected on days 15 and 21. Maternal blood samples were collected at 2 hours \pm 30 mins post-dose. The remaining five rats per group were allowed to deliver. On LDs 0, 3, 7, 14, and 21, the pups were counted, weighed (genders separate), and examined for abnormal appearance and behavior. Randomly selected pups were sacrificed and blood samples were collected. On LDs 3, 7, 14, and 21, the dams were anesthetized and milk and blood samples were collected; dams were removed from their litters 1–2 hours prior to collection. Plasma, milk, amniotic fluid extract, and tissue homogenate (i.e., placenta, embryo, and fetus) supernatants were analyzed for PFOA concentrations by HPLC/MS.

All dams survived and there were no clinical signs of toxicity. In the 30-mg/kg/day group, mean body weight gain was approximately 10% lower than in the control group during gestation, and mean body weight was approximately 4% lower than for controls throughout gestation and lactation. The number of implantation sites, resorptions, and live fetuses were comparable among groups on days 10, 15, and 21 of gestation. One dam in the 3-mg/kg/day group and two dams in the 30-mg/kg/day group delivered small litters (3–6 pups per litter compared to 12–19 pups per litter in the control group); however, given the small sample size, the biological significance of this finding is unclear. There were no clinical signs of toxicity in the pups, and pup survival and body weights were comparable among groups. Under the conditions of this study, the maternal LOAEL was 30 mg/kg/day for decreased body weight gain during gestation, and the NOAEL was 10 mg/kg/day. The developmental NOAEL was 30 mg/kg/day.

Mouse. Lau et al. (2006) conducted a developmental toxicity study of PFOA in mice to ascertain whether there was a gender-related difference in the bioaccumulation of PFOA in the mouse and to evaluate the effects of PFOA on prenatal and postnatal development in offspring exposed during pregnancy. In that study, groups averaging 9–45 timed-pregnant CD-1 mice were given 0, 1, 3, 5, 10, 20, and 40 mg/kg PFOA daily by oral gavage on GDs 1–17. Maternal weight was monitored during gestation. Dams were divided into two groups. In the first group, dams were sacrificed on GD 18 and underwent maternal and fetal examinations that included measure of maternal liver weight and examination of the gravid uterus for numbers of live and dead fetuses

and resorptions. Maternal blood was collected and analyzed for PFOA serum concentration. PFOA levels in the fetuses were not examined. Live fetuses were weighed and subjected to external gross necropsy and skeletal and visceral examinations. In the second group of dams, an additional dose of PFOA was administered on GD 18. Dams were allowed to give birth on GD 19.

The day following parturition was designated as PND 1. Time of parturition, condition of newborns, and number of live offspring were recorded. The number of live pups in each litter and pup body weight were noted for the first 4 days after birth and then at corresponding intervals thereafter. Eye opening was recorded beginning at PND 12. Pups were weaned on PND 23 and separated by gender. The time to sexual maturity was determined by monitoring vaginal opening and preputial separation beginning on PND 24. Two to four pups per gender per litter were randomly selected for observation of postnatal survival, growth, and development. Estrous cyclicity was determined daily by vaginal cytology. After weaning, dams were sacrificed and the contents of the uteri examined for implantation sites. Postnatal survival was calculated based on the number of implantations for each dam.

Signs of maternal toxicity were observed following exposure to PFOA during pregnancy. Statistically significant dose-related increases ($p \leq 0.05$) in maternal liver weight also were observed, beginning at 1 mg/kg/day. Dose-related decreases in maternal weight gain during pregnancy were observed beginning at 5 mg/kg/day, with statistical significance ($p \leq 0.05$) seen in the 20- and 40-mg/kg/day dose groups. Under the conditions of the study, a maternal LOAEL of 1 mg/kg was indicated based on increased liver weight, and a NOAEL was not established. Signs of developmental toxicity were observed following *in utero* exposure to PFOA. The number of implantations in treated mice was comparable to control mice. Statistically significant increases ($p \leq 0.05$) in full-litter resorptions were reported at doses of ≥ 5 mg/kg/day, with complete loss of pregnancies at the highest dose group of 40 mg/kg/day. A 20% reduction ($p \leq 0.05$) in live fetal body weight at term was reported at 20 mg/kg/day. A statistically significant increase in prenatal loss was observed in the 20-mg/kg/day dose group. Ossification (number of sites) of the forelimb proximal phalanges was significantly reduced at all doses except 5 mg/kg. Ossification of hindlimb proximal phalanges was significantly reduced at all doses except 3 and 5 mg/kg. Reduced ossification ($p \leq 0.05$) of the calvaria and enlarged fontanel was observed at 1, 3, and 20 mg/kg and at ≥ 10 mg/kg in the supraoccipital bone. Statistically significant increases ($p \leq 0.05$) in minor limb and tail defects were observed in the fetuses at doses ≥ 5 mg/kg/day. Under the conditions of the study, a prenatal developmental LOAEL of 1 mg/kg was indicated based on increased skeletal defects, and the NOAEL was not established.

Slight, but statistically significant, increases ($p \leq 0.05$) in the average time to parturition were observed at 10 and 20 mg/kg/day. Increases ($p \leq 0.05$) in stillbirths and neonatal mortality (or decreases in postnatal survival) were observed at doses ≥ 5 mg/kg/day, with as much as a 30% increase in these effects seen in the 10- and 20-mg/kg/day dose groups. Postnatal survival and viability in the 1- and 3-mg/kg/day dose groups were comparable to controls. At doses ≥ 3 mg/kg/day, a trend in growth retardation (body weight reductions of 25–30%; $p \leq 0.05$), was observed in the neonates at weaning. Body weights were at control levels by 6 weeks of age for females and by 13 weeks of age for males. A trend for increasing body weight (~6–10% greater than controls) was observed in animals dosed with 5 mg/kg at 13 weeks and in animals dosed with 1 and 3 mg/kg at 48 weeks. Deficits in early postnatal growth and development also were manifested by significant delays ($p \leq 0.05$) in eye opening at doses ≥ 5 mg/kg/day. Slight delays

($p \leq 0.05$) in vaginal opening and in time to estrous were observed at 20 mg/kg/day in females; in contrast, significant accelerations ($p \leq 0.05$) in sexual maturation were observed in males, with preputial separation occurring 4 days earlier than controls at the 1-mg/kg/day dose and 2–3 days earlier in the 3–10-mg/kg/day dose groups, but the 20-mg/kg/day dose group was only slightly delayed compared to controls. Under the conditions of the study, a LOAEL for developmental toxicity of 1 mg/kg/day for males was indicated based on accelerated pubertal development, and a NOAEL was not established. For females, the developmental LOAEL was 3 mg/kg/day based on growth retardation, and the NOAEL was 1 mg/kg/day.

Values for the benchmark dose (BMD) and the lower 95th percentile confidence bound on the BMD (BMDL) for the maternal and developmental endpoints (BMD₅ and BMDL₅) were calculated by the study authors and reported in Lau et al. (2006). For maternal toxicity, BMD₅ and BMDL₅ estimates for decreases in maternal weight gain during pregnancy were 6.76 and 3.58 mg/kg/day, respectively. For increases in maternal liver weight at term, BMD₅ and BMDL₅ estimates were 0.20 mg/kg/day and 0.17 mg/kg/day, respectively. BMD₅ and BMDL₅ estimates for the incidence of neonatal mortality (determined by survival to weaning) at 5 mg/kg/day were 2.84 and 1.09 mg/kg/day, respectively. Significant alterations in postnatal growth and development were observed at 1 and 3 mg/kg/day, with BMD₅ and BMDL₅ estimates of 1.07 and 0.86 mg/kg/day, respectively, for decreased pup weight at weaning; and 2.64 and 2.10 mg/kg/day, respectively, for delays in eye opening. The BMD₅ and BMDL₅ estimates for reduced phalangeal ossification were < 1 mg/kg/day. BMD₅ and BMDL₅ estimates for reduced fetal weight at term were estimated to be 10.3 and 4.3 mg/kg/day, respectively.

Male and female 129S1/SvImJ and PPAR α -null mice were used in studies to determine if PFOA-induced developmental toxicity was mediated by PPAR α (Abbott et al. 2007). Pregnant 129S1/SvImJ wild-type and PPAR α -null mice were orally dosed from GD 1–17 with 0, 0.1, 0.3, 0.6, 1, 3, 5, 10, and 20 mg PFOA/kg/day. Heterozygous (HET) litters also were produced by mating wild-type and PPAR α -null males with wild-type and PPAR α -null dams to determine if genetic background affected survival. The HET litters were sacrificed on PND 15. Survival at birth was recorded and live offspring counted and weighed by gender. Litters were counted and offspring weighed on PND 1–10, 14, 17, and 22. Weaning occurred on PND 22, and all dams and one pup per litter were sacrificed. Blood was collected and the uteri were stained for implantation counts.

There was no effect of treatment on maternal weight or maternal weight gain (excluding nonpregnant females and those with full-litter resorptions), number of implants, or pup weight at birth. Wild-type dams exposed to ≥ 0.6 mg/kg/day and PPAR α -null dams exposed to ≥ 5 mg/kg/day had a significantly greater percentage of litter loss compared to their respective controls. At ≥ 5 mg/kg/day in wild-type dams and 20 mg/kg/day in PPAR α -null dams, 100% litter loss occurred. Relative liver weight was significantly increased in wild-type adult females dosed with ≥ 1 mg/kg/day and in PPAR α -null adult females dosed with ≥ 3 mg/kg/day.

Body weight in wild-type offspring born of dams dosed with 1.0 mg/kg/day was significantly reduced ($p < 0.05$) compared to control offspring body weight gain on PND 9, 10, and 22 (males) and PND 7–10 and PND 22 (females). No differences were observed between PPAR α -null offspring body weight and control offspring body weight. Survival of pups from birth to weaning was significantly reduced ($p < 0.05$) in wild-type litters exposed to ≥ 0.6 mg/kg/day, but was not affected in PPAR α -null litters. Survival was significantly decreased ($p < 0.05$) for wild-type and HET pups born to wild-type dams dosed with 1 mg/kg/day and for HET pups born to PPAR α -null dams dosed with 3 mg/kg. Offspring born of wild-type dams showed a dose-related trend for

delayed eye opening compared to control offspring (significantly delayed at 1 mg/kg/day, $p < 0.05$), but no difference in day of eye opening was observed in the offspring born of PPAR α -null dams. At weaning, relative liver weight was significantly increased ($p < 0.05$) in wild-type offspring gestationally exposed to ≥ 0.1 mg/kg/day and in PPAR α -null offspring gestationally exposed to 3 mg/kg/day.

The authors concluded that survival of PPAR α -null pups and deaths of HET pups born to PPAR α -null dams indicates that expression of PPAR α is required for PFOA-induced postnatal lethality; however, early prenatal lethality was independent of PPAR α . Delayed eye opening and reduced postnatal weight gain appeared to be mediated by PPAR α , but other mechanisms might also contribute. Under the conditions of the study, the maternal/reproductive LOAEL for wild-type mice was 0.6 mg/kg/day based on increased percentage of litter loss, and the NOAEL was 0.3 mg/kg/day. The developmental LOAEL for wild-type offspring was 0.1 mg/kg/day based on increased liver weight, and the NOAEL was not established. The maternal LOAEL for PPAR α -null mice was 3 mg/kg/day based on increased liver weight, and the NOAEL was 1 mg/kg/day. The developmental LOAEL for PPAR α -null offspring was 3 mg/kg/day based on increased liver weight, and the NOAEL was 1 mg/kg/day.

To further evaluate the developmental effects potentially mediated by PPAR α , groups of female wild-type, PPAR α -null, and PPAR α -humanized mice were given 0 and 3 mg PFOA/kg on GDs 1–17 by oral gavage (Albrecht et al. 2013). Controls received the water vehicle. Females were either sacrificed on GD 18 ($n = 5–8$ per group) or allowed to give birth and then sacrificed, along with their litters ($n = 8–14$), on PND 20. Livers from dams, fetuses, and pups were weighed and collected for histopathological evaluation and RNA analysis. Gene expression results are given in section 3.3.4. Mammary gland whole mounts were prepared from female pups on PND 20 for quantification of ductal length and number of terminal end buds; these results are described below with other studies evaluating the effects of PFOA on mammary gland development.

Evaluation on GD 18 showed no effects of PFOA administration on maternal body weight, body weight gain, gravid uterine weight, number of implantations per dam, or number of resorptions per litter in dams of any genotype. For animals allowed to litter, the average day of parturition was slightly later in PFOA-treated humanized mice than in the controls. Body weight of dams during lactation, the number of pups born per litter, pup body weight during lactation, and the onset of pup eye opening were similar between treated and control groups for all genotypes. Offspring survival during PNDs 1–5 was significantly reduced in the wild-type PFOA-treated group, but not in the other genotypes.

Maternal liver weight was significantly increased in the treated groups of all genotypes on GD 18 and in wild-type animals on PND 20. Maternal liver weight was not affected on PND 20 in the PPAR α -null or PPAR α -humanized mice. Relative fetal liver weight on GD 18 was significantly increased in fetuses from treated wild-type and humanized dams. On PND 20, relative liver weight was increased only in pups from treated wild-type dams. Microscopic evaluation of the maternal liver showed centrilobular hepatocellular hypertrophy in all PFOA-treated groups on GD 18 and PND 20, with decreased incidence and severity by PND 20. On GD 18, the liver lesions were graded as mild in the wild-type mice, minimal-to-mild in the humanized mice, and minimal in the null mice. The morphological features of the liver lesions differed slightly between genotypes and are described in more detail in section 3.4.1. Only wild-type fetuses and pups from treated dams showed similar liver lesions.

Yahia et al. (2010) gavaged pregnant ICR mice (n = 5 per group) with 0, 1, 5, and 10 mg PFOA/kg/day from GDs 0–17 or 0–18. The dams dosed from GDs 0–17 were sacrificed on GD 18, and the fetal skeletal morphology was evaluated. Dams dosed from GDs 0–18 were allowed to give birth and their offspring were either processed for pathological examination or observed for 4 days for neonatal mortality. Maternal liver, kidney, brain, and lungs were histologically examined after necropsy. Serum was collected for clinical chemistry and lipid analysis. Body weight was significantly decreased in dams receiving 10 mg/kg/day. Maternal absolute liver weight was significantly increased ($p < 0.05$) at doses ≥ 5 mg/kg/day and relative liver and kidney weights were significantly increased at all doses. Hepatic hypertrophy was localized to the centrilobular region at the two lower doses and was diffuse at the highest dose. Renal cells in the outer medullar and proximal tubule were slightly hypertrophic at all doses. Treatment with 10 mg/kg/day caused a significant increase in AST, ALT, GGT, and ALP and a significant decrease in total serum protein, albumin, globulin, triglycerides, phospholipids, TC, and free fatty acids. At 5 mg/kg/day, total serum protein and globulin were significantly decreased, and phosphorus was increased. At 1 mg/kg/day, BUN and phosphorus were significantly increased. The maternal LOAEL was 1 mg/kg/day based on significantly increased relative liver and kidney weight, and no NOAEL was established.

Live fetal birth weight was significantly decreased at the two highest doses. There was no difference in the percentage of live fetuses between treated and control groups. At 10 mg/kg/day, increased incidence of cleft sternum, reduced phalanges ossification, and delayed eruption of incisors was observed. Delayed parturition was observed in dams treated with 10 mg/kg/day, and ~58% of all pups born to those dams were stillborn. Death occurred within 6 hours of delivery in the remaining pups, and whole body edema was observed in some of the pups. The body weight of the live pups born to dams treated with 5 or 10 mg/kg/day was significantly reduced compared to control pup body weight. By PND 4, 16% of offspring born to dams dosed with 5 mg/kg/day had died. No pathological differences were observed in the lungs or brains of treated and control offspring. The developmental LOAEL was 5 mg/kg/day based on decreased body weight and decreased survival rate, and the NOAEL was 1 mg/kg/day.

Suh et al. (2011) examined placental prolactin-family hormone and fetal growth retardation in mice treated with PFOA. Pregnant CD-1 mice (n = 10 per group) were treated with 0, 2, 10, and 25 mg/kg/day PFOA from GDs 11–16. Dams were sacrificed on GD 16 and uteri were removed and examined. Three placentas per group were analyzed histochemically and the numbers of glycogen trophoblast cell (GlyT) in the junctional zone plus sinusoidal trophoblast giant cells (S-TGC) in the labyrinth zone were counted and compared. Trophoblast cells express prolactin-family genes. mRNA from three placentas per group were analyzed using situ hybridization, northern blot hybridization, and RT-PCR for mouse placental lactogen- (mPL-) II, mouse prolactin-like protein- (mPLP-) E and F, Pit-1 α , and β isotype (transacting factors of mPL and mPLP genes).

A significant difference in maternal body weight was observed from GD 13–16 in dams treated with 25 mg/kg/day of PFOA compared to controls. At ≥ 2 mg/kg/day of PFOA, placental weight was significantly decreased and the number of resorptions and dead fetuses was significantly increased. At ≥ 10 mg/kg/day of PFOA, fetal weight and the number of live fetuses were significantly decreased. There were no differences in the number of implantation sites among the groups, and postimplantation loss was 3.87, 8.83, 30.98, and 55.41% for the 0, 2, 10, and 25 mg/kg/day PFOA groups, respectively.

The placentas of dams dosed with ≥ 10 mg/kg/day of PFOA displayed necrotic changes. Parietal and S-TGC and GlyT cell frequency in the placental junctional and labyrinth zones was significantly decreased ($p < 0.05$) in a dose-dependent manner in treated dams. At 25 mg/kg/day of PFOA, S-TGCs showed signs of atrophy with crushed cell nucleus. A significant dose-dependent decrease in mPL-II, mPLP-E, mPLP-F, and Pit-1 α and β isotype mRNA and expression was observed. Correlation coefficients between fetal weight and maternal mPL-II, mPLP-E, and mPLP-F mRNA levels were positive ($p < 0.001$). Based on the results, the authors suggested that inhibited prolactin-family gene expression could be secondary to insufficient trophoblast cell differentiation and increased cell necrosis. These effects reduced placental efficiency and contributed in part to fetal growth retardation. The 2-mg/kg/day dose was a LOAEL for increases in resorption and dead fetuses plus decreased placental weight. There was no NOAEL.

A meta-analysis was conducted to determine whether developmental exposure to PFOA was associated with fetal growth effects in animals (Kousta et al. 2014). Eight studies identified in the published literature met the criteria of the Navigation Guide systematic review methodology for inclusion in the analysis (Woodruff and Sutton 2014). The data sets included mouse gavage studies with offspring body weight at birth. Maternal PFOA doses ranged from 0.01 to 20 mg/kg/day. The results from the meta-analysis showed that a 1-mg/kg/day increase in PFOA dose was associated with a -0.023 g (95% CI -0.029, -0.016) difference in pup birth weight. All of the studies included in the analysis are described either above with the developmental toxicity studies or with the specialized developmental studies that follow.

3.2.7 Mammary Gland Development and Other Specialized Developmental Studies

The following studies used experimental study designs and/or examined endpoints not typically included in standard developmental toxicity studies. The studies were conducted to determine critical periods of exposure for outcomes that occurred later in life. A number of the studies focused on mammary gland development in dams and female offspring. Researchers focused on effects resulting from indirect exposure of offspring via treatment of pregnant animals and/or direct exposure of peripubertal animals starting about the time of weaning.

Indirect gestational and/or lactational exposures

Many studies evaluating indirect gestational and/or lactational exposure to PFOA are available and Table 3-21 provides an overview of experiments designed to assess the developmental effects of PFOA following exposures during gestation. Most of the studies focus on mammary gland effects as a consequence of gestational and lactational or prepubertal exposures in CD-1 mice. Some have included postnatal assessment of the liver. Additional details of the studies are described in the section following the table.

Timed pregnant CD-1 mice were given PFOA by gavage at doses of 0, 0.01, 0.1, 0.03, and 1 mg/kg/day from GD 1 through the end of lactation (PND 21) in a study by Quist et al. (2015). The litters were equalized on PND 4 to four females and six males. Only the females continued in the study after weaning. At the end of lactation, litters with less than four females were removed from the study. On PND 21, seven to 10 female pups per dose group were sacrificed by decapitation. The livers were removed for analysis.

Table 3-21. Studies of Pregnant CD-1 Mice Following Administration of PFOA

Dose (mg PFOA /kg/day)	Timing	Endpoints	Reference
0, 0.01, 0.1, 0.3, 1	GD 1 to PND 21	Liver histopathology; periportal inflammation; clinical chemistry; impact of postweaning HFD	Quist et al. 2015
0, 5	GD 1-17, 8-17, or 12-17	Body weight; mammary gland morphology GD 18 (dams) and PNDs 10 and 20 (dams, female pups)	White et al. 2007
0, 5 20	GD 7-17, 10-17, 13-17, 15-17 GD 15-17	Body weight; developmental landmarks and growth to PND 189; mammary gland morphology of female pups up to 18 months	White et al. 2009; Wolf et al. 2007
0, 3, 5	GD 1-17 Cross-fostered at birth	Body weight; developmental landmarks and growth to PND 245; mammary gland morphology of female pups up to 18 months	White et al. 2009; Wolf et al. 2007;
0, 5	GD 8-17 Cross-fostered at birth	Mammary gland morphology of dams and female pups on PNDs 1, 3, 5, and 10	White et al. 2009
0, 0.3, 1.0, 3	GD 1-17	Liver weight; mammary gland morphology of female pups on PNDs 7, 14, 21, 28, 42, 63, and 84	Macon et al. 2011
0, 0.01, 0.1, 1	GD 10-17		
0, 1, 5	GD 1-17	Body weight; reproductive parameters; mammary gland morphology of F0, F1, and F2 females	White et al. 2011
0, 1 + 5 ppb in drinking water to both groups	GD 1-17 Drinking water started on GD 7 and continued to F2 generation		
0, 3	GD 1-17	Wild-type, PPAR α -null, and hPPAR α vv/129 mice; pup body weight at PNDs 14 and 20 plus mammary gland structure	Albrecht et al. 2013
0, 0.01, 0.1, 0.3, 1	GD 1-17 Study included both CD-1 and C57BL/6 mice	Body weight; net body weight; absolute and relative liver weight on PNDs 21, 35, and 56; serum estradiol and progesterone; mammary gland morphology	Tucker et al. 2015

During the lactation period all pups received a Purina control diet with a normal fat content. At sacrifice on PND 21, there was a dose-related increase in relative liver weight at doses ≥ 0.3 mg/kg/day. When the animals from the same dose group were sacrificed on PND 91, there was no observed impact on relative liver weight.

Starting on PND 35, one pup from each of 20 dams was placed on a HFD (with 60% of the calories from fat) until sacrificed on PND 91. Half were fasted for 4 hours before blood collection and sacrifice. Another seven to 10 pups per dose group received the Purina control diet with lower fat content until their sacrifice on PND 91. Blood samples were collected at sacrifice for determination of ALP, AST, ALT, SDH, LDL, HDL, cholesterol, triglycerides, total bile acid (TBA), glucose, leptin and insulin. Liver sections were collected for histological analysis and graded 1 to 4 for lesion severity (1 = minimal; 4 = severe). Selected samples of the liver tissues (four from the HFD groups and four from the PFOA-exposed control diet group) were fixed in osmium trioxide and prepared for evaluation using transmission electron microscopy.

At PND 91, the animals on the PFOA + HFD weighed more than the Purina controls. The body weight for the group that received PFOA and the control diet did not differ from the untreated controls on the same diet. Serum samples from the PFOA-treated Purina controls, and the fasted high-fat and nonfasted high-fat groups were analyzed for LDL, HDL, TC, and leptin.

At PFOA doses < 0.3 mg/kg/day, the LDL and TC levels in the fasted and nonfasted HFD animals were greater than in the untreated Purina controls. There was no impact of PFOS on either parameter in animals on the PFOA plus Purina control diet, but both LDL and TC were statistically lower at the high PFOA dose than they were at the low doses for both parameters. A similar pattern was seen for the HDL levels.

The impact of PFOA dose on leptin was variable and not significant for the PFOA plus Purina control animals and the high-fat, fasted animals. For the high-fat, nonfasted animals, there was a trend towards decreasing leptin as the PFOA dose increased, which was significant at the high dose of 1 mg/kg/day ($P < 0.01$). In those animals, the liver showed chronic periportal inflammation and microvesicular intracytoplasmic lipid droplets. The transmission electron microscopy slides showed that the hypertrophic liver cells presented evidence of cellular damage and changes in both mitochondrial morphology and numbers. The observed mitochondrial abnormalities were not those generally associated with PPAR α activation. The 0.01 mg/kg/day dose was a NOAEL. The LOAEL was 0.3 mg/kg/day for the effects on TC for animals receiving a HFD, but not for those receiving the PFOA plus Purina control diet.

Effects of PFOA exposure on mammary gland morphology of CD-1 mice were evaluated in a series of studies by the same researchers (Macon et al. 2011; Tucker et al. 2015; White et al. 2007, 2009, 2011). The focus was on mammary gland development of female pups, although limited evaluations were conducted on the dams. Mammary gland whole mounts were scored on a 1 to 4 subjective, age-adjusted, developmental scale (1 = poor development/structure; 4 = normal development/structure). Tissue was assessed qualitatively for the gross presence of several histological criteria by two independent scorers and a mean score calculated. Neither standardization of these subjective measures nor training of the scorers was described in the publications. Quantitative measures of longitudinal growth, lateral growth, and number of terminal end buds also were made in the Macon et al. (2011) and Albrecht et al. (2013) studies.

White et al. (2007) orally dosed pregnant CD-1 mice with 0 and 5 mg PFOA/kg/day on GD 1–17 ($n = 14$), 8–17 ($n = 16$), and 12–17 ($n = 16$) to determine if decreased neonatal body weights and survival were linked to gestational exposure or lactational changes in milk quantity or quality. The control mice ($n = 14$) were dosed with vehicle on GD1–17. A subset of dams was sacrificed on GD 18. The remaining dams were allowed to give birth, and pups were pooled and randomly redistributed among the dams of the respective treatment groups. Litters were equalized to 10 pups per litter. Half of the dams and litters were sacrificed on PND 10, and the remaining dams and litters were sacrificed on PND 20. Mammary glands were collected from dams and female pups at time of sacrifice.

Treatment with PFOA did not affect maternal weight gain, number of implants, or the number of live fetuses. There was a significant increase ($p < 0.05$) in prenatal loss in dams exposed during GD1–17. Body weight of pups exposed gestationally to PFOA was significantly decreased ($p < 0.05$) at all time points measured and for all dosing regimens. On GD 18, stunted alveolar development was observed in the mammary gland of dams treated with PFOA on GD 1–17 compared to the mammary glands of the control dams, which were saturated with milk-filled alveoli. Dams treated with PFOA on GD 1–17 or 8–17 exhibited significant mammary gland epithelial differentiation delays on PND 10 as evidenced by an excessive amount of adipose tissue. In comparison, mammary glands from control dams on PND 10 were well differentiated, full of alveoli filled with milk, and contained few apoptotic bodies and little adipose tissue. The mammary gland developmental score in dams treated on GD 12–17 was not

statistically different from control dams on PND 10. At PND 20, the mammary gland scores from all PFOA-treated dams were not significantly different from those of the control group.

The pups were impacted by their *in utero* PFOA exposure over all dosing intervals. Their mammary glands exhibited significantly stunted epithelial branching and longitudinal growth at PNDs 10 and 20; the resulting developmental scores were significantly less than those of controls. Very little mammary gland development occurred between PND 10–20 in the offspring of dams exposed to PFOA, even though postnatal growth and body weight gain increased in parallel to that of the controls. Thus, at the only dose tested, 5 mg/kg/day, effects were observed on the dam and pup mammary gland, accompanied by decreased pup body weight and decreased survival for the pups exposed during GD 1–17.

In the study by Wolf et al. (2007), CD-1 mice were orally dosed with 0 and 5 mg PFOA/kg/day on GD 7–17 (n = 14), 10–17 (n = 14), 13–17 (n = 12), and 15–17 (n = 12) or with 20 mg/kg on GD 15–17 (n = 6) to determine if there was a specific window during which PFOA exposure produced developmental effects. The developmental results from this study were published by Wolf et al. (2007) and the mammary gland effects were published by White et al. (2009). On PND 22, all dams and one male and female pup from each litter were necropsied. Blood samples were collected and livers from dams and offspring were removed and weighed. Uterine implantation sites were counted. The fourth and fifth inguinal mammary glands were removed from female offspring and analyzed at various intervals up to 18 months of age (White et al. 2009). Mammary gland whole mounts from female offspring between PNDs 22 and 32 were scored as described above; whole mounts from lactating dams and female offspring at 18 months were qualitatively examined with respect to concurrent controls.

Maternal weight gain was increased in dams exposed to PFOA beginning on GDs 7 and 10, but there was no effect on number of uterine implantation sites, litter loss, or number of pups per litter at birth. Male pup weight at birth was significantly decreased ($p < 0.05$) in dams dosed with 5 mg/kg/day on GD 7–17 or 10–17 or with 20 mg/kg/day on GD 15–17. By PND 78, all male offspring had recovered to control body weight levels. On PND 161, the offspring of dams dosed during GD 13–17 weighed significantly more than control. Litters exposed to 20 mg/kg/day on GD 15–17 experienced decreased survival ($p < 0.01$) during PND 1–22. Maternal relative liver weight was significantly increased in all PFOA-treated dams except those treated during GD 15–17. Relative liver weight in all male and female pups was significantly increased ($p < 0.01$). Eye opening and growth of body hair were delayed in pups exposed GD 7–17 and 10–17 (Wolf et al. 2007).

Mammary gland developmental scores for all offspring of dams exposed to PFOA were significantly lower compared to scores from offspring of control dams at PND 29 and 32. Delayed ductal elongation and branching and delayed appearance of terminal end buds were characteristic of delayed mammary gland development at PND 32. At 18 months of age, mammary tissues were not scored due to a lack of a protocol applicable to mature animals. However, there were dark foci (composition unknown) in the mammary tissue that occurred at a higher frequency in the exposed animals compared to controls, but did not display a consistent response with dosing interval. Qualitatively, mammary glands from treated dams on LD 1 appeared immature compared with control dams (White et al. 2009). The 5-mg/kg/day dose was associated with increased maternal and pup liver weight, altered pup mammary gland development, and delayed pup eye opening and growth of body hair. The 20-mg/kg/day dose was associated with decreased postnatal pup survival.

The objective of a second component of the study by Wolf et al. (2007) and White et al. (2009) was to determine if postnatal body weight deficits, neonatal lethality, and developmental delays caused by PFOA exposure were the result of gestational exposure, lactational exposure, or a combination of gestational and lactational exposure. Pregnant CD-1 mice were orally dosed with 0 (n = 48), 3 (n = 28), and 5 (n = 36) mg PFOA/kg/day on GD 1–17 and their offspring cross-fostered at birth to create seven treatment groups: control, *in utero* exposure only (3U and 5U), lactation exposure only (PFOA stored in milk during gestation and released during lactation; 3L and 5L), and *in utero* and lactation exposure (3U+L and 5U+L). On PND 22, all dams and one male and female pup from each litter were necropsied. Blood samples were collected and the liver was removed from dams and offspring and weighed. Implantation sites were counted from the uteri of dams. The fourth and fifth inguinal mammary glands were removed from female offspring and analyzed at various intervals up to 18 months of age (White et al. 2009). Mammary gland whole mounts from female offspring between PND 22 and 63 were scored as described above; whole mounts from female offspring at 18 months were qualitatively examined with respect to concurrent controls due to lack of an applicable protocol for mature animals.

Maternal weight and weight gain were higher in PFOA-treated dams compared to control dams. Whole litter loss was significantly increased ($p < 0.05$) at 5 mg/kg/day, but no differences in the number of implantation sites were observed between the treated and control mice. Absolute and relative liver weights of PFOA-treated dams from both dose groups were significantly increased ($p < 0.001$) compared to absolute and relative liver weights of control dams 23 days after the last dose (PND 22). No difference in the number of live pups born per litter was found between treated and control mice, but male and female pup birth weight was reduced ($p < 0.01$) in dams receiving 5 mg/kg/day (Wolf et al. 2007). The 3-mg/kg/day dose was a LOAEL for increases in liver weight in the dams while 5 mg/kg/day was a LOAEL for the pups, based on whole litter loss and significantly reduced male and female birth weight.

A dose-dependent increase of PFOA was observed in the serum of dams treated with PFOA, providing a reservoir for lactational transfer. The control dams that nursed offspring exposed *in utero* (3U and 5U) had low concentrations of PFOA in their serum that originated from maternal grooming behavior of the pups and allowed for low-level lactational transfer.

Body weight of male and female pups (3U+L, 5U, and 5U+L) was significantly reduced as early as PND 2 and 1, respectively, and remained reduced throughout the lactation period. Body weight recovery to control levels was reached by male offspring within 2 weeks of weaning, but recovery in female offspring in the 5U and 5U+L groups did not occur until after PND 85.

Postnatal survival in 5U+L pups was significantly decreased compared to control survival beginning at PND 4 and continuing throughout lactation. Survival in the other groups was no different than control survival. Eye opening and body hair growth were significantly delayed in the 3U+L, 5U, and 5U+L offspring. The relative liver weight was significantly increased in all offspring regardless of exposure scenario (Wolf et al. 2007).

All female offspring of PFOA-exposed dams had reduced mammary gland developmental scores at PND 22, except for females in the 3L group. At PND 42, mammary gland scores from females in the 3U+L group were the only ones not statistically different from control scores. This might have been due to interindividual variance and multiple criteria used to calculate mammary gland development scores. All offspring of dams exposed to PFOA exhibited delayed mammary gland development at PND 63, including those exposed only through lactation (3L and 5L). A

higher density of dark staining foci was observed in the mammary glands of these animals at 18 months of age (White et al. 2009).

White et al. (2009) also reported the results from pregnant CD-1 mice orally dosed with 0 (n = 56) and 5 (n = 56) mg PFOA/kg/day from GD 8–17 to determine the timing of the mammary gland development deficits observed following gestational or lactational exposure to PFOA. The groups were cross-fostered at birth to create four treatment groups: control, *in utero* exposure only (5U), lactation exposure only (5L), and *in utero* and lactation exposure (5U+L). Dams and litters were sacrificed on PNDs 1, 3, 5, and 10. Blood and liver samples were collected for PFOA analysis. The fourth and fifth inguinal mammary glands were collected from dams and female offspring and analyzed as described above; whole mounts from lactating dams were qualitatively examined with respect to concurrent controls.

Maternal weight gain in treated dams was significantly higher than control weight gain, but there were no effects of treatment on litter size or pup birth weight at PND 1. Significantly decreased body weight occurred in the pups of the 5U+L group on PND 3 and in all PFOA-exposed pups on PNDs 5 and 10. Relative liver weight of the treated dams was significantly increased ($p < 0.05$) compared to relative liver weight of control dams. On PND 1, liver-to-body weight ratios were significantly increased ($p < 0.05$) in pups exposed *in utero* (5U, 5U+L); serum PFOA levels were 65,000–70,000 ng/mL. The liver-to-body weight ratio was increased in pups exposed lactationally by PND 5; serum PFOA levels were approximately 15,000 ng/mL (White et al. 2009).

On PND 1, the mammary glands of PFOA-exposed dams were qualitatively similar to glands seen in late pregnancy, prior to parturition. In control dams nursing offspring from PFOA-exposed dams, reduced alveolar filling was noted as early as PND 3, presumably a result of exposure of the dam from maternal grooming behavior. The delayed lactational morphology in dams treated with PFOA and control dams nursing offspring from PFOA-treated dams was persistent up to PND 10 (terminal sacrifice). Reduced mammary gland developmental scores were observed as early as PND 1 in all female offspring from PFOA-exposed dams, including those exposed through lactation only (5L). Delayed mammary gland development persisted throughout the study duration (White et al. 2009).

Macon et al. (2011) gavaged CD-1 mice with 0, 0.3, 1.0, and 3.0 mg PFOA/kg/day from GD 1–17 (n = 13 dams per group). Six offspring per group were sacrificed on PNDs 7, 14, 21, 28, 42, 63, and 84, and blood, liver, brain, and the fourth and fifth mammary glands were collected from female pups. Mammary gland developmental scores were not included in the published article, but were available in supplemental materials.

Body weight in male and female offspring was not affected through PND 84. Absolute liver weight was significantly increased at ≥ 0.3 mg/kg/day in females and at ≥ 1.0 mg/kg/day in males on PND 7, and at 3.0 mg/kg in females at PND 14. Relative liver weight was significantly increased at ≥ 0.3 mg/kg/day in males and females on PND 7, at ≥ 1.0 mg/kg/day in females on PND 14, and at 3.0 mg/kg/day in males and females on PNDs 14, 21, and 28. No dose-related differences were observed in absolute and relative brain weights.

Delayed mammary gland development of female pups was observed as early as PND 7 at ≥ 1.0 mg/kg/day and PND 14 at ≥ 0.3 mg/kg/day and persisted until the end of the study. However, the developmental scores did not show dose-related trends at each interval. The delayed development was characterized by reduced epithelial growth and the presence of

numerous terminal end buds. Photographs of the mammary gland whole mounts at PNDs 21 and 84 show differences in the duct development and branching pattern of offspring from dams given 0.3 and 1 mg/kg/day (offspring from high-dose dams not pictured). The LOAEL was 0.30 mg/kg/day based on significantly increased liver weight and delayed mammary gland development. No NOAEL was established. The lowest dose tested was a NOAEL at PND day 7 and is a LOAEL at day PND 14.

Macon et al. (2011) also gavaged CD-1 mice with 0, 0.01, 0.1, and 1.0 mg PFOA/kg/day from GD 10–17 (n = 5–8 dams per group) to examine the effects of low doses of PFOA on mammary gland development. Female offspring (one from at least three litters per group) were sacrificed on PNDs 1, 4, 7, 14, and 21, and blood, liver, and the fourth and fifth mammary glands were collected. In addition to the qualitative mammary gland developmental scores, quantitative measurements of longitudinal growth, lateral growth, and numbers of terminal end buds and terminal ends were recorded. These data were presented only for animals sacrificed on PND 21.

No differences in body weight or brain weight were observed for male or female offspring. At 1 mg/kg, absolute and relative liver weights were significantly increased at PNDs 4 and 7. Relative liver weight also was significantly increased at PND 14. Mammary gland development was delayed by exposure to PFOA, especially longitudinal epithelial growth. At PND 21, all treatment groups had significantly lower developmental scores. At the highest dose, poor longitudinal epithelial growth and decreased number of terminal end buds were observed. As seen in Table 3-22, the quantitative measures were statistically significant only for the high dose compared to the controls, while the qualitative scores were significantly different from controls at all doses. The LOAEL was 0.01 mg PFOA/kg/day based on the qualitative / quantitative developmental score for mammary gland development and 1 mg/kg/day based on the quantitative score in the absence of the qualitative component. No NOAEL was established.

Table 3-22. Mammary Gland Measurements at PND 21 from Female Offspring of Dams Treated GD 10–17

Dose mg/kg/d	Score	Longitude μm	Lateral μm	Δ Longitude μm	Δ Lateral μm	TEBs #/gland	TEs #/gland
0 n = 5	3.3 \pm 0.3	4321 \pm 306	5941 \pm 280	3394 \pm 306	4358 \pm 280	40 \pm 4	81 \pm 12
0.01 n = 4	2.2 \pm 0.2*	3803 \pm 386	5420 \pm 326	3087 \pm 386	3899 \pm 326	33 \pm 4	61 \pm 8
0.1 n = 3	1.8 \pm 0.3**	3615 \pm 320	4822 \pm 672	2370 \pm 320	3035 \pm 672	24 \pm 4	58 \pm 4
1.0 n = 5	1.6 \pm 0.1***	2775 \pm 285**	4822 \pm 313**	1553 \pm 301	3380 \pm 313	15 \pm 2***	47 \pm 11
Longitude = longitudinal epithelial growth Lateral = Lateral epithelial growth Δ = change in * = p < 0.05, ** p < 0.01, *** p < 0.001				# = number TEBs = terminal end buds TE = differentiating duct ends			

Source: Macon et al. 2011

White et al. (2011) examined the extended consequences of PFOA-induced altered mammary gland development in a multigenerational study in CD-1 mice. Pregnant mice (F0, n = 10–12 dams per group) were gavaged with 0, 1, and 5 mg PFOA/kg/day from GD 1–17. A separate group of pregnant mice (n = 7–10 dams per group) was gavaged with either 0 or 1 mg PFOA/kg/day from GD 1–17 and received drinking water containing 5 ppb PFOA beginning on GD 7. F1 females and F2 offspring from the second group continued to receive drinking water that contained 5 ppb PFOA until the end of the study, except during F1 breeding and early gestation, to simulate a chronic low-dose exposure. Only the F0 dams were given

PFOA by gavage. Total doses were not calculated for the groups receiving drinking water with 5 ppb PFOA. Table 3-23 shows the array of dosing regimens used in the study and the estimated average daily PFOA intake by F0 dams. The average daily intake from the chronic water exposures were calculated from total weekly water consumption, divided by the number of days per week (values given in supplemental materials; intake by the F1 animals was not calculated).

Table 3-23. Dosing Regimens Used in the Multigeneration Study of CD-1 Mice

	F0 Dams	F0 Dams → F1 Offspring		F1 Dams → F2 Offspring	F2 Offspring
Treatment	Gavage	Drinking water	Gavage + drinking water	Drinking water	Drinking water
Dose	0, 1, or 5 mg/kg/day	0+5 ppb	1+5 ppb	5 ppb	5 ppb
Duration Gavage Drinking water	GD 1-17 None	GD 1-17 GD 7-LD 22	GD 1-17 GD 7-LD 22	None Through LD 22	None Through PND 63
Total Daily PFOA intake to dams from gavage and drinking water	Not relevant (0 mg/kg/day) 36 µg/day (1 mg/kg/day) 187 µg/day (5 mg/kg/day)	0.054 µg/day (gestation) 0.105 µg/day (lactation)	37 + 0.051 µg/day (gestation) 0 + 0.130 µg/day (lactation)	Not calculated	Not calculated

Source: White et al. 2011

F0 females were sacrificed on PND 22. F1 offspring were weaned on PND 22 and bred at 7–8 weeks of age. F2 litters were maintained through PND 63. Groups of F1 and F2 offspring (n = 1–2 offspring per litter from 5–7 litters per group) were sacrificed on PND 22, 42, and 63. A group of F2 offspring (n = 6–10 per group) also was sacrificed on PND 10. A lactational challenge experiment was performed on PND 10 with F1 dams and F2 offspring. Mammary glands were evaluated from F0 dams on PND 22, from F1 dams on PNDs 10 and 22, and from F1 and F2 female offspring on PNDs 10 (F2 only), 22, 42, and 63. Mammary gland whole mounts were scored qualitatively as described above.

Exposure to 5 mg PFOA/kg/day significantly increased prenatal loss in F0 mice and significantly decreased the number of live offspring and the postnatal survival of the viable pups. Maternal weight gain and number of implants did not differ among F0 the groups. There was no indication of toxicity in F1 adult females. Exposure to PFOA did not affect prenatal loss or postnatal survival, although F1 females that had been exposed *in utero* to 5 mg/kg/day had significantly fewer implants.

On PND 22, F1 pup body weight was similar across all treated and control groups. F1 offspring body weight at PND 42 was significantly reduced for those whose dams received 5 mg/kg/day; at PND 63, body weight was significantly reduced for offspring from dams given 1 mg/kg/day plus 5 ppb in the drinking water compared to offspring from dams given 1 mg/kg/day. Liver-to-body weight ratios were significantly increased at 1 mg/kg/day on PND 22 and at 5 mg/kg on PNDs 22 and 42. For the F2 pups, a significant reduction in body weight was observed in control plus 5 ppb drinking water PFOA offspring on PND 1, but there was no difference by PND 3. F2 offspring from the 1 mg/kg/day and 1 mg/kg/day plus 5-ppb drinking water PFOA groups had increased body weight compared to controls on PNDs 14, 17, and 22. Liver-to-body weight ratios were no different across the groups.

Mammary gland developmental scores for the three generations of females are summarized in Table 3-24. At PND 22, control F0 dams displayed weaning-induced mammary involution. At PND 22, the mammary glands of all PFOA-exposed F0 dams, including the control dams receiving 5 ppb PFOA in drinking water, resembled glands of mice at or near the peak of lactation (~PND 10). The F1 dams examined on PNDs 10 and 22 had significantly lower developmental scores on PND 10, but that was no longer evident at PND 22, except for those exposed *in utero* to 5 mg/kg/day.

Table 3-24. Mammary Gland Scores from Three Generations of CD-1 Female Mice

Group	Control	Control +5 ppb	1 mg/kg/day	1 mg/kg/day + 5 ppb	5 mg/kg/day
F0 dams on PND 22	2.4 ± 0.2	3.4 ± 0.1*	3.0 ± 0.2*	3.2 ± 0.2*	3.9 ± 0.1*
F1 as pups PND 63	3.8 ± 0.2	2.6 ± 0.4*	2.9 ± 0.2*	2.0 ± 0.3*#	2.2 ± 0.2*
F1 as dams on PND 10	4.0 ± 0.0	2.8 ± 0.5*	2.5 ± 0.2*	2.0 ± 0.2*	2.5 ± 0.2*
F1 as dams on PND 22	2.1 ± 0.3	2.2 ± 0.2	1.9 ± 0.4	1.5 ± 0.2*	3.2 ± 0.3*
F2 PND 10	2.8 ± 0.3	3.0 ± 0.2	1.9 ± 0.3	2.6 ± 0.2	2.0 ± 0.2
F2 PND 22	3.1 ± 0.4	1.9 ± 0.3	2.3 ± 0.1	2.3 ± 0.2	2.0 ± 0.2
F2 PND 42	3.5 ± 0.2	2.5 ± 0.4*	3.4 ± 0.2	2.4 ± 0.2*#	3.3 ± 0.4
F2 PND 63	3.4 ± 0.2	3.5 ± 0.2	2.4 ± 0.2*	2.6 ± 0.5	2.6 ± 0.4

Notes: n = 4–11.

* p<0.05 compared with control.

p<0.05 compared with 1 mg/kg/day.

F1 and F2 animals represented in each data set are different. They represent members of litters within each group at different stages of development.

In the F1 female offspring not used for breeding, the mammary glands of all mice exposed to PFOA were significantly delayed in development on PNDs 22, 42, and 63. For the F2 female offspring, some differences in mammary gland scores were observed between the groups, but most were not significantly different from controls.

In the lactational challenge experiment, dams were removed from their litters for 3 hours, then returned to their litters and allowed to nurse for 30 mins. The time from the dam's return to the litter and nursing initiation was recorded. The litters were weighed before and after nursing to estimate volume of milk produced. The results from the lactational challenge on PND 10 for the F1 dams showed a slight dose-related trend for decreased milk production (measured in grams) over a 30-min period (differences from controls not identified as significant), but no clear differences in time to initiate nursing (measured in seconds). As discussed above, morphological differences were seen in developmental scores for the treated F1 dams on PND 10 and were generally no longer evident at PND 22.

White et al. (2011) demonstrated that no significant dose-related differences were found in the ability of the CD-1 mice given 1 mg/kg/day to provide nourishment to their young as reflected in measurements of body weight in F1 and F2 pups across a 63-day postnatal period. There were body weight effects in the pups from dams given 5 mg/kg/day and in pups from dams that received 1 mg/kg/day by gavage with 5 ppb in the drinking water.

In the study by Albrecht et al. (2013) discussed earlier, groups of female wild-type, PPAR α -null, and PPAR α -humanized mice on a SV/129 genetic background were given 0 and 3 mg PFOA/kg on GD 1–17 by oral gavage. Controls received the water vehicle. The study was

designed with the goal of identifying the contribution of PPAR α activation to the responses evaluated. Mammary gland structure was one of the endpoints evaluated. Females were either sacrificed on GD 18 (n = 5–8 per group) or allowed to give birth and then sacrificed, along with their litters (n = 8–14), on PND 20. The left and right fourth and fifth mammary glands were removed, spread on a glass slide, and stained. Ductal length and terminal end buds were quantified in the offspring of from three to nine dams. There was no significant difference in the measurements for either parameter at either timepoint for the offspring of PFOA-treated animals compared to the controls. In the case of the wild-type mice, the terminal end bud measurements were 2.1 ± 0.01 terminal end buds/gland for the control and 2.2 ± 0.2 terminal end buds/gland based on the mean for three control litters and four PFOA-exposed litters. For the ductal lengths, the values were 2.4 ± 0.3 millimeter (mm) for the control and 2.4 ± 0.4 mm for the PFOA-exposed animals. There was no qualitative component of the scoring approach used by Albrecht et al. (2013). The fewest number of terminal end buds and the longest ductal length measurement were those for the animals with the hPPAR α .

To examine the impact of differences in mouse strains, Tucker et al. (2015) conducted a study of the effects of gestational exposure on mammary gland development as measured at prepubertal time points. Doses of 0, 0.01, 0.1, 0.3, and 1 mg/kg/day were administered to timed pregnant CD-1 and C57Bl/6 mice by gavage on GD 1–17. After parturition, the number of pups was reduced so that there were ultimately four to eight CD-1 litters per treatment block and three to seven B57BL/6 litters per treatment. Endpoints monitored included body weight; net body weight; absolute and relative liver weight on PNDs 21, 35, and 56; neonatal developmental endpoints (e.g., vaginal opening, first estrus); and serum estradiol and progesterone (P) measurement; and as well as mammary gland development scores. Qualitative assessment of mammary gland scores was as described above. Different treatment blocks monitored different endpoints at different times. Serum POA levels were measured at PNDs 21, 35, and 56 for the CD-1 mice (n = 4–12) and at PND 21 and 61 for the C57BL/6 mice (n = 2–6). At each time point, the serum concentration increased with dose and decreased with duration.

There were no measures that were significantly ($p < 0.05$) different from controls for the CD-1 anthropometric parameters, except relative liver weight on PND 56 at 0.3 mg/g/day and on PND 21 at 1 mg/kg/day. Net body weight was significantly increased ($p < 0.05$) at PNDs 21 and 35 in the 1-mg/kg/day group. No significant differences were observed in the C57Bl/6 mice at any dose or duration. There were no significant differences for postnatal developmental endpoints, estradiol, or P in either mouse strain. There was a trend towards decreasing mammary gland developmental scores with dose for both strains of mice. In the CD-1 mice, mammary gland developmental scores were significantly reduced at ≥ 0.01 mg/kg/day on PND 35 and at ≥ 0.1 mg/kg/day on PND 21 compared to scores in the controls. However, in the C57Bl/6 mice, mammary gland developmental scores were significantly reduced only at 0.3 and 1.0 mg/kg/day on PND 21 compared to scores in the controls.

Serum P was higher in the control and treated CD-1 mice on PND 56 than at the other two time points but lacked dose response; estradiol was relatively consistent across time points. For the C57BL/6 mice, the estradiol levels at PND 61 were higher in all treated groups but lacked dose-response; P changed little with time and was similar between treated and control groups. The LOAEL was 0.01 mg/kg/day for aberrant mammary gland development in the CD-1 mice and 0.3 mg/kg/day for the C57BL/6 mice. The CD-1 mice lacked a NOAEL. The NOAEL for the C57/BL/6 mice was 0.1 mg/kg/day. Although both strains experienced delayed prepubertal mammary gland development, there were no significant changes in other postnatal

developmental events. The relevance of the mammary gland changes at maturity in the absence of any postlactational PFOA exposure is uncertain, especially as it relates to humans.

Direct peripubertal exposures

C. Yang et al. (2009) gavaged 21-day-old female BALB/c mice (5 per group) with 0, 1, 5, and 10 mg PFOA/kg/day for 5 days per week for 4 weeks to determine the effects of peripubertal PFOA exposure on puberty and mammary gland development. At necropsy, uteri and livers were weighed and processed for histological examination. Mammary glands were collected and processed for histological and whole-mount examination. A significant decrease in body weight was observed following exposure to 10 mg/kg/day. The mammary glands of female BALB/c mice treated with 5 or 10 mg/kg/day had reduced ductal length, decreased number of terminal end buds, and decreased stimulated terminal ducts compared to the mammary glands of control mice. BrdU incorporation into the mammary gland revealed a significantly lower number of proliferating cells in the ducts and terminal end buds/terminal ducts at 5 mg/kg/day (not tested at 10 mg/kg/day). Absolute and relative liver weight was significantly increased in all treated BALB/c mice. The absolute and relative uterine weight was significantly decreased in all treated mice compared to uterine weight in control mice. Vaginal opening was significantly delayed in mice dosed with 1 mg/kg/day and did not occur at 5 or 10 mg/kg/day. The LOAEL was 1 mg/kg/day based on delayed vaginal opening, increased liver weight, and decreased uterine weight; and no NOAEL was established.

C. Yang et al. (2009) also dosed 21-day-old female C57BL/6 mice in the same manner as the BALB/c mice and examined the effects of PFOA on mammary gland development and vaginal opening. The body weight effects were similar in both strains with 10 mg/kg/day causing significantly reduced body weight. At 5 mg/kg/day, PFOA had a stimulatory effect on the mammary glands. There was a significant increase in the number of terminal end buds and stimulated terminal ducts. Ductal length was not affected. Mammary gland development was inhibited in mice dosed with 10 mg/kg/day, with no terminal end buds or stimulated terminal ducts present and very little ductal growth. Absolute and relative liver weight was significantly increased in all treated mice. The absolute and relative uterine weight was significantly increased in C57BL/6 mice dosed with 1 mg/kg/day and significantly decreased in C57BL/6 mice dosed with 10 mg/kg/day. There was no difference in uterine weights between mice treated with 5 mg/kg/day and control mice. Vaginal opening was delayed in C57BL/6 mice dosed with 5 mg/kg/day and did not occur in mice dosed with 10 mg/kg/day. The LOAEL was 1 mg/kg/day based on increased liver and uterine weights, and no NOAEL was established.

Y. Zhao et al. (2010) conducted several experiments in C57BL/6 mice to determine the potential mechanism by which peripubertal PFOA exposure resulted in the stimulation of mammary gland development observed by C. Yang et al. (2009). In experiments to determine if PFOA has a hormonal effect on mammary gland development, C57BL/6 mice (n = 10 per group) were OVX at 3 weeks of age, allowed 1 week to recover, and treated with 0 and 5 mg PFOA/kg bw/day for 4 weeks. Abdominal and inguinal mammary glands were collected at sacrifice, prepared as whole mounts, and scored for growth and development. The mammary glands of the OVX control and PFOA-treated OVX mice were similarly stunted in growth as evidenced by no outgrowth of ducts or presence of terminal end buds. This was in contrast to the stimulatory effect of PFOA observed by C. Yang et al. (2009) in intact mice.

In experiments to determine if PFOA-affected mammary glands respond to hormone treatment, intact C57BL/6 mice were dosed with 0 or 5 mg/kg bw/day of PFOA for 4 weeks

starting at 21 days of age. After the last dose, the mice were OVX, allowed to recover for 1 week, and injected subcutaneous for 5 days with E2 (1 μ g/0.2 ml per mouse), P (1 mg/0.2 ml per mouse), or both (E+P, 1 μ g+1 mg/0.2 ml per mouse). The mice were sacrificed 24 hours after the last hormone injection. Abdominal and inguinal mammary glands were collected at sacrifice, prepared as whole mounts, and scored for growth and development. In the mammary glands of mice treated with PFOA and estradiol, stimulated terminal ducts were observed, and in PFOA-treated mice given P or E+P, stimulated terminal ducts and an increased number of side branches were observed. The results showed that PFOA increased the mouse mammary gland response to exogenous estrogen and P.

In experiments to determine if PFOA-induced mammary gland development stimulation is related to PPAR α expression and the impact of PFOA on steroid hormones and growth factors, female C57BL/6 and PPAR α -null C57BL/6 mice (n = 5–10 mice per group) were gavage-dosed with 0 or 5 mg/kg bw/day of PFOA 5 days per weeks for 4 weeks starting at 21 days of age (Y. Zhao et al. 2010). Vaginal opening was monitored daily and estrous cycle state was determined at sacrifice after 4 weeks of treatment. At necropsy, blood was collected for measurement of serum steroid hormones and binding proteins. Portions of the mammary glands, ovaries, and livers were collected and processed for histological examination. RNA was extracted from the livers for quantitative RT-PCR and PCR array for selected genes related to metabolism of drugs, toxic chemicals, hormones, and micronutrients. Portions of mammary glands were used in western blot analysis of several enzymes, local growth factors, and receptors, including aromatase—which aids in converting testosterone to estradiol and androstenedione to estrone, hydroxysteroid 17 β dehydrogenase 1 (HSD17 β 1)—which aids in converting estrone to estradiol, and hydroxysteroid 3 β dehydrogenase 1 (HSD3 β 1)—which aids in converting pregnenolone to P and androstenedione to testosterone. Growth factors critically involved in mammary gland development, including amphiregulin (Areg), insulin like growth factor I (IGF-I), and hepatocyte growth factor (HGF α), and markers of cell proliferation (e.g., cyclin D1 and PCNA) were analyzed by western blot. Areg mediates estrogen receptor α (ER α) function and is a ligand for the epidermal growth factor receptor (EGFR). These receptors also were analyzed by western blot.

The mammary glands of PPAR α -null mice treated with PFOA had an increased number of terminal end buds and stimulated terminal ducts compared to control PPAR α -null mice. Protein levels of Areg, IGF-I, HGF α , ER α , and EGFR were significantly increased (p<0.05) in PFOA-treated C57BL/6 mice; and Areg, HGF α , ER α , and EGFR were significantly increased (p<0.05) in PFOA-treated PPAR α -null mice. Cyclin D1 and PCNA were significantly increased (p<0.05) in C57BL/6 and PPAR α -null mice treated with PFOA compared to levels in control mice. Immunofluorescent staining of the mammary glands for ER α and Areg showed a significant increase (p<0.05) in Areg positive luminal epithelial cells and Areg and ER α double positive staining cells in C57BL/6 and PPAR α -null mice treated with PFOA compared to control mice. The results show that the stimulatory effect of PFOA on mammary gland development is independent of PPAR α expression and suggest that PFOA increases the levels of steroid hormones, growth factors, and receptors, which promote mammary gland cell proliferation.

Estradiol levels were similar between intact control and treated wild-type mice, but P levels were significantly increased (p<0.05) in PFOA-treated mice in proestrus and estrus compared to control mice in the same stages of the estrous cycle. Serum SHBG and albumin levels were not significantly changed by treatment with PFOA.

The effect of PFOA on aromatase, HSD17 β 1, and HSD3 β 1 activity in the ovaries of C57BL/6 PPAR α -null mice was examined. In C57BL/6 mice, HSD17 β 1 and HSD3 β 1 proteins were significantly increased ($p < 0.05$), and in PPAR α -null mice, HSD17 β 1 protein was significantly increased. Aromatase levels were not affected by PFOA. The results suggest that PFOA might increase serum steroid hormone levels in the ovaries.

Due to the increased P levels observed in PFOA-treated mice, the expression of liver metabolic enzymes was analyzed. Liver metabolic function might affect steroid hormone serum levels, which play a role in mammary gland development. In PPAR α -null and C57BL/6 mice treated with PFOA, detoxification enzymes in the liver, including glutathione s-transferase α 1, μ 3, and μ 4, were upregulated ($p < 0.05$). Expression of liver drug metabolic enzymes, including CYP1a1, CYP1a2, and HSD17 β 2, was significantly downregulated ($p < 0.05$) in C57BL/6 mice treated with PFOA, but expression in PFOA-treated PPAR α -null mice was comparable to that in control mice. Hydroxysteroid 17 β dehydrogenase 4, an enzyme that converts estradiol to estrone, was significantly upregulated ($p < 0.05$) in C57BL/6 mice treated with PFOA. The results suggested that PFOA-induced expression changes in liver enzymes might not contribute to PFOA-induced mammary gland development stimulation.

Inhalation Exposure

Staples et al. (1984) exposed Sprague-Dawley rats to PFOA using whole-body dust inhalation for 6 hours per day on GD 6–15. The MMAD of the particles ranged from 1.4 to 3.4 μ m and the GSD ranged from 4.3 to 6.0. The study was carried out in two trials with each trial including two experiments. In experiment 1, the dams were sacrificed on GD 21 prior to parturition, and in experiment 2, the dams were allowed to litter and were sacrificed on PND 23; offspring were sacrificed on PND 35. In the trial 1 (both experiments), dams ($n = 12$) were exposed to 0, 0.1, 1, and 25 mg/m^3 . In trial 2, the high dose was reduced to 10 mg/m^3 . In experiment 1 of trial 2, dams numbered 12–15 per group and two additional groups (6 dams per group) were added and were pair-fed at 10 and 25 mg/m^3 . In experiment 2 of trial 2, only six control and six dams dosed at 10 mg/m^3 were allowed to litter.

In experiment 1, the dams were weighed on GDs 1, 6, 9, 13, 16, and 21 and observed daily for abnormal clinical signs. On GD 21, the dams were sacrificed by cervical dislocation and examined for any gross abnormalities, liver weights were recorded, and the reproductive status of each animal was evaluated. The ovaries, uterus, and contents were examined for the number of corpora lutea, live and dead fetuses, resorptions, and implantation sites. Pups (live and dead) were counted, weighed and sexed, and examined for external, visceral, and skeletal alterations. The heads of all control and high-dosed group fetuses were examined for visceral alterations and macroscopic and microscopic evaluations were conducted of the eyes.

Treatment-related clinical signs of maternal toxicity occurred at 10 and 25 mg/m^3 and consisted of wet abdomens, chromodacryorrhea, chromorhinorrhea, a general unkempt appearance, and lethargy in four dams at the end of the exposure period (high-concentration group only). Three out of 12 dams died during treatment at 25 mg/m^3 (on GDs 12, 13, and 17). Food consumption was significantly reduced at 10 and 25 mg/m^3 ; however, no significant differences were noted between treated and pair-fed groups. Significant reductions in body weight also were observed at these concentrations, with statistical significance at the high concentration only. Likewise, statistically significant increases in mean liver weights ($p < 0.05$) were seen in the high-concentration group. The NOAEL and LOAEL for maternal toxicity were 1 and 10 mg/m^3 , respectively.

No effects were observed on the maintenance of pregnancy or the incidence of resorptions. Mean fetal body weights were significantly decreased in the 25 mg/m³ PFOA group (p = 0.002) and in the pair-fed control group (p = 0.001). Interpretation of the decreased fetal body weight is difficult given the high incidence of mortality in the dams. The NOAEL and LOAEL for developmental toxicity were 10 and 25 mg/m³, respectively.

In experiment 2, in which the dams were allowed to litter, the procedure was the same as for experiment 1 until GD 21. Two days before the expected day of parturition, each dam was housed in an individual cage. The date of parturition was noted and designated PND 1. Dams were weighed and examined for clinical signs on PNDs 1, 7, 14, and 22. On PND 23 all dams were sacrificed. Pups were counted, weighed, and examined for external alterations. At birth, each pup was subsequently weighed and then inspected for adverse clinical signs on PNDs 4, 7, 14, and 22. The eyes of the pups were also examined on PNDs 15 and 17. Pups were sacrificed on PND 35 and examined for visceral and skeletal alterations.

Clinical signs of maternal toxicity seen at 10 and 25 mg/m³ were similar in type and incidence to those described for trial 1. Maternal body weight gain during treatment at 25 mg/m³ was less than controls, although the difference was not statistically significant. In addition, two out of 12 dams died during treatment at 25 mg/m³. No other treatment-related effects were reported, nor were any adverse effects noted for any of the measurements of reproductive performance. The NOAEL and LOAEL for maternal toxicity were 1 and 10 mg/m³, respectively.

Signs of developmental toxicity in this group consisted of statistically significant reductions in pup body weight on PND 1 (6.1 g at 25 mg/m³ versus 6.8 g in controls, p = 0.02). On PNDs 4 and 22, pup body weight continued to remain lower than controls, although the difference was not statistically significant. No significant effects were reported following external examination of the pups or with ophthalmoscopic examination of the eyes. The NOAEL and LOAEL for developmental toxicity were 10 and 25 mg/m³, respectively.

Dermal Exposure

No data on the developmental effects of dermal exposures to PFOA were identified in the literature.

3.2.8 Chronic Toxicity

Oral Exposure

Monkey. Male cynomolgus monkeys (n = 4 or 6 per dose) were administered PFOA by oral capsule containing 0, 3, 10, or 30/20 mg/kg/day for 26 weeks (Butenhoff et al. 2002). Dosing of animals in the 30-mg/kg/day dose group ceased after 12 days and decreased to 20 mg/kg/day when reinstated on day 22 because of low food consumption, decreased body weight, and decreased feces. Sacrifice of the surviving monkeys, except for two control monkeys and two monkeys from the mid-dose group (recovery animals) occurred at 26 weeks. The animals in the recovery groups were sacrificed 13 weeks later.

Animals were observed twice daily for mortality and moribundity and were examined at least once daily for signs of poor health or abnormal behavior. Ophthalmic examinations were performed before treatment began and at weeks 26 and 40. Body weight, food consumption, clinical hematology, clinical chemistry, urinalysis, serum hormone levels, and PFOA levels in

blood and tissue were assessed throughout the study. One animal from the 30/20-mg/kg/day dose group was sacrificed in moribund condition on day 29 with signs of dosing injury and liver lesions. One animal from the 3-mg/kg/day dose was sacrificed (day 137) with signs of hind limb paralysis, ataxia and hypoactive behavior, few feces, and no food consumption. Treatment of the remaining three animals given 30/20 mg/kg/day was halted on days 43, 66, and 81, respectively, because of thin appearance, few or no feces, low or no food consumption, and weight loss, but the animals appeared to recover from compound-related effects within 3 weeks after cessation of treatment. No significant changes in mean body weight were observed at doses of 3 or 10 mg/kg/day.

Serum hormone levels (i.e., estrone, estradiol, estriol, testosterone, TSH, FT4, total T4, and CCK) were not significantly altered throughout the study. However, FT3 and total T3 levels were significantly decreased ($p < 0.05$) from weeks 5 to 10 and at week 27 in the 30/20-mg/kg/day dose group compared to controls.

At terminal sacrifice (26 weeks), mean absolute liver weight was significantly increased in all dose groups and the relative liver-to-body weight ratio was significantly increased for the High-Dose Group. Final Body Weight And Liver Weight Data Are Presented In Table 3-25.

Table 3-25. Liver Weight Data in Monkeys Administered PFOA for 6 Months

Dose	Body Weight	Absolute Liver Wt (g)	Relative Liver Wt (%)
0 mg/kg (n = 4)	3947 ± 591	60.2 ± 6.9	1.5 ± 0.1
3 mg/kg (n = 3)	4486 ± 30	81.8 ± 2.8*	1.8 ± 0.1
10 mg/kg (n = 4)	4447 ± 498	83.2 ± 9.7*	1.9 ± 0.1
30/20 mg/kg (n = 2)	3925 ± 583	90.4 ± 4.2*	2.4 ± 0.5*

Source: Butenhoff et al. 2002

Note: * Significantly different from control, $p < 0.01$.

The cause of the increase in liver weight was suggested to be hepatocellular hypertrophy (indicated by decreased hepatic DNA content), which was hypothesized to result from mitochondrial proliferation based on an increase in hepatic succinate dehydrogenase activity. The two animals given 20 mg/kg/day had significantly decreased hepatic DNA content, and increased succinate dehydrogenase and palmitoyl-CoA oxidase activities; glucose-6-phosphatase activity was slightly decreased in all treated groups, but a dose-response was not shown. These data are shown in Table 3-26. Succinate dehydrogenase activity was highly variable in animals given 3 mg/kg/day despite this group having the most consistent liver PFOA concentrations. Although serum steady-state had been attained by 4-6 weeks of dosing (Table 3-26 (see section 2.2, Distribution), liver PFOA levels ranged from 11.3-18.5, 6.29-21.9, and 16-83.3 $\mu\text{g/g}$ tissue in the 3, 10, and 20 mg/kg/day groups, respectively.

Because administration of PFOA to rats has been shown to result in liver, Leydig cell tumors (LCTs), and pancreatic acinar cell tumors (PACTs), Butenhoff et al. (2002) analyzed markers of tumor formation in the monkey study just described. In the liver, a twofold increase in hepatic palmitoyl-CoA oxidase activity was observed in the 30/20-mg/kg/day group, consistent with reports for species that are not particularly responsive to PPAR α agonists. Replicative DNA synthesis in the liver, an indication of cell proliferation, was not altered in the treated animals. It also has been proposed that changes associated with the PACTs in rats include increased serum CCK concentrations and indications of cholestasis, including increases in ALP, bilirubin, and bile acids. None of these changes were observed in the cynomolgus monkeys. There were also no significant changes in estradiol, estriol, or testosterone in the monkeys. Each of these factors

is associated with LCTs in rats. There were no changes in replicative DNA synthesis in the pancreas or testes.

Table 3-26. Subcellular Liver Enzyme Activities and Liver PFOA Concentrations

Endpoint	0 mg/kg/day	3 mg/kg/day	10 mg/kg/day	20 mg/kg/day
DNA (mg/g liver)	1.44 ± 0.28	1.23 ± 0.89	1.25 ± 0.37	1.02 ± 0.17*
Succinate dehydrogenase (µmol cytochrome c reduced/min/g liver)	0.21 ± 0.15	1.77 ± 1.59	0.55 ± 0.14	1.37 ± 0.73*
Palmitoyl-CoA oxidation (µmol/min/g liver)	0.53 ± 0.12	0.47 ± 0.13	0.90 ± 0.29	1.36 ± 0.34*
Acid phosphatase (µmol/min/g liver)	0.78 ± 0.10	0.81 ± 0.11	0.80 ± 0.14	0.55 ± 0.10
Glucose-6-phosphatase (µmol/min/g liver)	12.32 ± 3.11	6.02 ± 0.33*	10.17 ± 0.63	8.83 ± 1.41
PFOA liver level (µg/g tissue) (individual animal)	0.09 <LOQ 0.23 <LOQ	15.2 18.5 11.3 18.3 (sacrificed day 137)	21.9 6.29 8.86 18.8	16.0 83.3

Source: Butenhoff et al. 2002

Notes:

* Significantly different from control, p<0.05.

<LOQ: less than the lower LOQ of 0.019 µg/g.

After a 13-week recovery period, there were no treatment-related effects on terminal body weights or on absolute or relative organ weights, suggesting that the treatment-related liver weight changes were reversible. There were no treatment-related macroscopic or microscopic changes at the recovery sacrifice. Toxicological significance of the parameters in Table 3-26 are difficult to evaluate because of the small number of animals and the high variability in the enzyme measurements and the liver PFOA levels.

Rat. The chronic toxicity of PFOA was investigated in a 2-year study in rats by Butenhoff et al. (2012); this study was conducted from April 1981 through May 1983. Sprague-Dawley (CrI:CD BR) rats (50 per gender) were fed diets containing 0, 30, and 300 ppm PFOA (0, 1.3, and 14.2 mg/kg/day for males; 0, 1.6, and 16.1 mg/kg/day for females). Groups of 15 additional rats per gender were fed 0 or 300 ppm PFOA and evaluated at the 1-year interim sacrifice. All animals were observed daily throughout the 2-year dosing period. Periodic observations included body weights and feed consumption, hematology, serum chemistry, urinalysis, gross pathology, organ weights, and histopathology. Animals were sacrificed after 1 and 2 years of dosing. Organ weights were determined after each sacrifice and tissues subjected to histological examination.

No dose- or treatment-related clinical signs of toxicity were observed in males or females. Significantly decreased body weight gains occurred in high-dose male and female rats compared to the controls. The body weight changes correlated with slight decreases in feed consumption during the study. Survival rate was increased for high-dose males and females compared with their respective controls, likely because of the lower body weights for these treated groups. No consistent dose-related changes over time were observed in hematology parameters of males and females. Clinical chemistry changes included slight (less than twofold) but significant increases in ALT, AST, and ALP in both treated male groups from 3 to 18 months, but only in the high-dose males at 24 months (Table 3-27); no differences were observed in females. No dose- or treatment-related differences in absolute and relative organ weights were found between the treated and control groups at 2 years.

Table 3-27. Clinical Chemistry Values from Male Rats Given PFOA for 2 Years

Endpoint	Diet Level (ppm)	3 Months	6 Months	12 Months	18 Months	24 Months
ALT (IU/L)	0	21.4 ± 2.67	24.1 ± 3.75	33.5 ± 19.45	34.1 ± 10.68	33.4 ± 8.1
	30	34.5 ± 15.33*	53.3 ± 29.34*	77.6 ± 56.59*	59.7 ± 33.41*	42.5 ± 10
	300	31.9 ± 21.94*	54.8 ± 29.26*	106.1 ± 70*	84.3 ± 55.95*	61.8 ± 20.13*
AST (IU/L)	0	45.3 ± 7.26	49.7 ± 14.98	79.1 ± 44.61	99.1 ± 68.14	64.9 ± 25.76
	30	59.7 ± 22.47	92.1 ± 45.6*	124.4 ± 94.04*	116.4 ± 57.99	68.0 ± 17.64
	300	58.2 ± 27.23	87.8 ± 34.83*	132.7 ± 76.84*	123.3 ± 62.98	95.7 ± 29.76*
ALP (mg/dL)	0	91.1 ± 26.22	97.1 ± 40.41	150.8 ± 43.94	85.2 ± 33.76	70.1 ± 25.53
	30	138.7 ± 33.14*	146.9 ± 37.13*	128.3 ± 41.75	112.5 ± 32.61	81.2 ± 26.2
	300	153.5 ± 31.84*	147.3 ± 34.85*	166.5 ± 59.28*	184.4 ± 73.37*	113.5 ± 22.84*

Source: Butenhoff et al. 2012

Note:

* Significantly different from control, $p \leq 0.05$.

Incidence of selected microscopic lesions is detailed in Table 3-28; severity scores were not given for any type of lesion. Significantly increased incidence of lesions in the liver was observed in the high-dose male group. At 1 year, diffuse hepatocellular hypertrophy, portal mononuclear cell infiltration, and hepatocellular necrosis were seen. At 2 years, significant increases in hepatocellular hypertrophy were observed in the males and females in the high-dose group. Hepatic cystoid degeneration, a condition characterized by areas of multilocular microcysts in the liver parenchyma, also was significantly increased in high-dose males. The incidence of hepatocellular necrosis did not increase for the high-dose males at the end of the study compared with the interim rate.

Among the high-dose males, histological changes were noted in tissues other than the liver. Small but statistically significant increases in vascular mineralization of the testes and of pulmonary hemorrhage probably were not caused by treatment with PFOA. In the lung, while the incidence of alveolar macrophages was increased, that of perivascular mononuclear infiltrate and of pneumonia were decreased and vascular mineralization was a common finding in treated and control animals.

The LOAEL for male rats is 300 ppm (14.2 mg/kg/day) based on a decrease in body weight gain and histological changes in the liver. The LOAEL for female rats is 300 ppm (16.1 mg/kg/day) based on decreased body weight gain. The NOAEL for both genders is 30 ppm (1.3 mg/kg/day for males and 1.6 mg/kg/kg for females).

Biegel et al. (2001) conducted a 2-year mechanistic study in which male Crl:CD BR (CD) rats (n = 156 per group) were fed a diet containing 0 or 300 ppm PFOA (0 or 13.6 mg/kg/day). Interim sacrifices were conducted every 3 months up to 21 months for measurements of liver and testes weights, peroxisome proliferation, and cell replication. Serum samples were collected and reproductive hormones measured.

Table 3-28. Incidence of Nonneoplastic Lesions in Rats Given PFOA for 2 Years

Lesion	0 ppm	30 ppm	300 ppm
Males			
Liver			
Cystoid degeneration	4/50	7/50	28/50*
Hepatocellular hypertrophy	0/50	6/50	40/50*
[incidence at 1 year]	[0/15]	[-]	[12/15]
Mononuclear cell infiltrate	37/50	32/50	48/50*
[incidence at 1 year]	[7/15]	[-]	[13/15]
Necrosis	3/50	5/50	5/50
[incidence at 1 year]	[0/15]	[-]	[6/15]
Lung			
Alveolar macrophages	10/49	16/50	31/49*
Hemorrhage	10/49	14/49	22/50*
Mononuclear infiltrate	21/49	3/49*	7/50*
Testes			
Vascular mineralization	0/49	3/50	9/50*
Females			
Liver			
Cystoid degeneration	0/50	0/50	0/50
Hepatocellular hypertrophy	0/50	1/50	8/50*
Mononuclear cell infiltrate	19/50	11/50	19/50
Necrosis	5/50	6/50	2/50

Source: Butenhoff et al. 2012

Notes:

* Significantly different from control, $p \leq 0.05$.

- Not examined; interim sacrifice not done on animals at 30 ppm.

Body weight was significantly decreased from days 8 through 630 in PFOA-exposed rats. In the treated group, relative liver weights and hepatic β -oxidation activity were statistically significantly increased at all time points between 1 and 21 months when compared to the controls. Absolute testis weights were significantly increased only at 24 months. No hepatic or Leydig cell proliferation was observed at any sampling times. The incidence of Leydig cell hyperplasia was significantly increased in PFOA-exposed rats (46% versus 14% in the control group). Pancreatic acinar cell proliferation was significantly increased at 15, 18, and 21 months. The incidence of acinar cell hyperplasia was 30/76 (39%) compared to the incidence in the control group of 14/80 (18%). There were no significant differences in serum testosterone or prolactin in the PFOA-treated rats when compared to the controls. Serum FSH was significantly increased at 6 months, and LH was significantly increased at 6 and 18 months. There were significant increases in serum estradiol concentrations in the treated rats at 1, 3, 6, 9, and 12 months.

3.2.9 Carcinogenicity

Oral Exposure

Rat. Tissues from the animals in the Butenhoff et al. study (2012) were evaluated for neoplastic and preneoplastic formations; this study was conducted from April 1981 through May 1983. Hepatocellular carcinomas were observed at 6% (3/49), 2% (1/50), and 10% (5/50) in the control, low-, and high-dose male rats, respectively. None were observed in females in the control and low-dose groups, but a 2% (1/50) incidence was observed for female rats in the high-

dose group. The differences between the treated and control groups were not significantly different. No liver adenomas were observed.

At the 1-year sacrifice, testicular masses were found in 7/50 (14%) high-dose and 2/50 (4%) low-dose rats, but not in any of the controls. A significant increase ($p < 0.05$) in the incidence of testicular (Leydig) cell adenomas was observed in the high-dose male rats at the end of the study. The LCT incidence in the control, low-, and high-dose groups was 0/50 (0%), 2/50 (4%), and 7/50 (14%), respectively. The increase also was statistically significant when compared to the historical control incidence of 0.82% observed in 1,340 Sprague-Dawley control male rats used in 17 carcinogenicity studies (Chandra et al. 1992). In a published workshop report on LCTs, Clegg et al. (1997) identified the spontaneous incidence of LCTs in 2-year-old Sprague-Dawley rats as approximately 5%.

A statistically significant, dose-related increase in the incidence of ovarian tubular hyperplasia was found in female rats at the 2-year sacrifice. The incidence of this lesion in the control, low-, and high-dose groups was 0%, 14%, and 32%, respectively. The biological significance of this effect at the time of the initial evaluation was unknown, as there was no evidence of progression to tumors.

Slides of the ovaries from the Butenhoff et al. study (2012)—originally conducted from April 1981 through May 1983—were reevaluated by Mann and Frame (2004) with emphasis placed on the proliferative lesions of the ovary. Using more recently published nomenclature, the ovarian lesions were diagnosed and graded as gonadal stromal hyperplasia and/or adenomas, which corresponded to the diagnoses of tubular hyperplasia or tubular adenoma by the original study pathologist. The data are summarized in Table 3-29. No statistically significant increases in hyperplasia (total number), adenomas, or hyperplasia/adenoma combined were seen in treated groups compared to controls. There was some evidence of an increase in size of stromal lesions observed at the 300-ppm group; however, adenomas occurred in greater incidence in the control group than in either of the treated groups. Results of this follow-up evaluation indicated that rats sacrificed at the 1-year interim sacrifice, as well as rats that died prior to the interim sacrifice, were not considered at risk for tumor development.

Table 3-29. Incidence of Ovarian Stromal Hyperplasia and Adenoma in Rats

Group	0 ppm	30 ppm	300 ppm
No. examined	45	47	46
Hyperplasia (Total)	8	16	15
Grade 1	6	7	5
Grade 2	2	3	1
Grade 3	0	5	6
Grade 4	0	1	3
Adenoma	4	0	2
Adenoma and/or Hyperplasia	12	16	17

Source: Mann and Frame 2004

Mammary gland tumors also were observed in the Butenhoff et al. (2012) bioassay. In the original analysis of mammary tissues from female rats, the incidence of fibroadenoma of the mammary gland in the female 300-ppm group (48%) was greater than that in either of the concurrent control groups (22%). It also was similar to the incidence in the 30-ppm group (42%), but considered to be within the norm for background variation of this lesion in Sprague-Dawley

rats based on the published literature. As a result of questions raised about this conclusion, a pathology working group (PWG) was commissioned to review the female mammary tumor findings, blinded to treatment status, using current diagnostic criteria (Hardisty et al. 2010). Table 3-30 compares the original mammary gland tumor findings to those of the PWG.

Table 3-30. Mammary Gland Tumor Incidence Comparison

	0 ppm		30 ppm		300 ppm	
	Butenhoff	Hardisty	Butenhoff	Hardisty	Butenhoff	Hardisty
Number necropsied	50	50	50	50	50	50
Lobular hyperplasia (%)	6 (12%)	0 (0%)	3 (6%)	2 (4%)	2 (4%)	0 (0%)
Adenocarcinoma (%)	8 (16%)	9 (18%)	14 (28%)	16 (32%)	5 (10%)	5 (10%)
Fibroadenoma ^a (%)	10 (20%)	18 (36%)	19 (38%)	22 (44%)	21 (42%)	23 (46%)
Adenoma (%)	3 (6%)	1 (2%)	0 (0%)	0 (0%)	0 (0%)	0 (0%)

Source: Hardisty 2005; Hardisty et al. 2010

Notes:

^a Includes fibroadenoma, multiple counts.

The principal differences between the original reported findings and the PWG results relate to changes in the mammary gland that were initially reported as lobular hyperplasia, which the PWG felt had features more characteristic of mammary gland fibroadenoma (Table 3-30). As a result, the numbers of rats with benign tumors (adenoma and fibroadenoma) were reclassified from 13 to 19 in the control group, from 19 to 22 in the 30-ppm group, and from 21 to 23 in the 300-ppm group. Although the incidence of neoplasms varied among the control and treated groups, there were no statistically significant differences when evaluated using the Fisher's exact test for pairwise comparison for fibroadenoma, adenocarcinoma, total benign neoplasms, and total malignant neoplasms. The morphologic appearance, overall incidence, and distribution of the neoplasms observed in treated and control groups were similar, resulting in a conclusion that they are not related to compound administration.

A 2-year mechanistic study in male Crl:CD BR (CD) rats (Biegel et al. 2001; Cook et al. 1992) resulted in liver tumors, LCTs, and PACTs. The rats (n = 156 per group) were fed diets containing 0 ppm (*ad libitum* control and control pair-fed to the PFOA-exposed rats) or 300-ppm PFOA (13.6 mg/kg intake). Rats were euthanized at interim time points of 1, 3, 6, 9, 12, 15, 18, and 21 months. All rats surviving the 24-month test period were necropsied for microscopic examination of various organs (e.g., kidneys, liver, testes, brain, heart, spleen). The incidence of liver adenomas in the *ad libitum* control, pair-fed control, and treated groups was 3% (2/80), 1% (1/79), and 13% (10/76), respectively. In the Butenhoff et al. study (2012), no hepatic adenomas were observed. The incidence for liver carcinomas was 0% (0/80), 3% (2/79), and 0% (0/76) in the *ad libitum* control, pair-fed control, and treated groups, respectively.

There was a significant increase in the incidence of Leydig cell adenomas in the treated rats—11% (8/76) when compared to the pair-fed control rats (3%, 2/78)—supporting the observations from the Butenhoff et al. study (2012). The incidence in *ad libitum* control rats was 0% (0/80). In addition, the treated group had a significant increase in the incidence of liver adenomas and pancreatic acinar cell adenomas when compared to the pair-fed and *ad libitum* control groups. The incidence for the pancreatic acinar cell adenomas was 0% (0/80) in the

treated rats, 1% (1/79) in the pair-fed control rats, and 9% (7/76) in the control rats. The incidence of pancreatic acinar cell carcinoma was 1% (1/76) in the treated rats, 0% (0/79) in the pair-fed control rats, and 0% (0/80) in the control rats.

In Butenhoff et al. (2012), there was no reported increase in the incidence of PACTs. However, the incidence of pancreatic acinar hyperplasia in the male rats was 0/33, 2/34, and 1/43 in the control, 30-, and 300-ppm groups, respectively. To resolve this discrepancy, the histological slides from both studies were reviewed by independent pathologists. This review of the microscopic lesions of the pancreas in the two studies indicated that PFOA produced increased incidence of proliferative acinar cell lesions of the pancreas in the rats of both studies at the dietary concentration of 300 ppm. The differences observed were quantitative rather than qualitative; more and larger focal proliferative acinar cell lesions and greater tendency for progression of lesions to adenoma of the pancreas were observed in the Biegel et al. study (2001) than in the Butenhoff et al. study (2012). The difference between pancreatic acinar hyperplasia (Butenhoff et al. 2012) and adenomas (Biegel et al. 2001) in the rat was a reflection of arbitrary diagnostic criteria and nomenclature by different pathologists. The basis for the quantitative difference in the lesions observed is not known, but was believed most likely to have been caused by the difference in the diets used in the two laboratories (Frame and McConnell 2003).

Mouse. Filgo et al. (2015) reported on tumor development in females from three strains of mice (CD-1, SV-139, and SV-129 PPAR α knock-out [KO]) at 18 months with exposures that occurred only during development (gestation and lactation). The animals were from separate experiments initially carried out by EPA and published as Hines et al. (2009) and Abbott et al. (2007). The Filgo et al. (2015) analysis focused on the mature offspring from the earlier publications and was carried out at the National Institute for Environmental Health Sciences (NIEHS). Dosing regimens differed for the individual strains as did the doses and the number of animals per dose group. Some of the animals in the original studies had died before the 18-month sacrifice at NIEHS. After sacrifice, the livers were recovered for analysis. The tissue sections were reviewed by a team of board-certified veterinary pathologists. Table 3-31 summarizes the tumor results.

Table 3-31. Liver Tumors in Three Strains of Mice at 18 Months with Exposure to PFOA Only during Gestation and Lactation

Strain	0 mg/kg/day	0.01 mg/kg/day	0.1 mg/kg/day	0.3 mg/kg/day	0.6 mg/kg/day	1 mg/kg/day	3 mg/kg/day	5 mg/kg/day
Number of Tumors / Total Number Tested								
Tumor Type								
CD-1	1/29 L	1/29 HCA	1/37 HCA	6/26 HCA(4), HCC, L	NT	2/31 HcyS, L	NT	6/21 HmS(2), HCA, HCC, HcyS, L
SV-129	0/10	NT	1/10 HcyS	0/8	0/6	0/8	NT	NT
SV-129- PPAR α KO	0/6	NT	1/10 HCA	2/10 HCA, ICT	NT	1/9 ICT	2/9 HCA	NT

Notes:

HCA = hepatocellular adenoma, HCC = hepatocellular carcinoma, HcyS = histocytic sarcoma, HmS = hemangeosarcomas, ICT = Ito cell tumor, L = lymphoma, NT = not tested.

It is difficult to draw conclusions regarding the carcinogenicity of PFOA in mice based on the data collected because of the small number of animals evaluated in both studies of SV-129 mice and the lack of PFOA exposure between PND 21 and 18 months for all dose groups. As was the case for liver tumors in the Butenhoff et al. study (2012), there is a lack of dose-response for total liver tumors, although the four hepatocellular adenomas seen at 0.3 mg/kg/day in CD-1 mice were significantly greater ($p < 0.05$) than the control. Tumor types varied across the dose groups. The authors also reported on preneoplastic basophilic, and eosinophilic foci were observed in the CD-1 mice but did not show a response to dose.

An interesting histological finding in both the CD-1 and SV-129 mice was a trend for increased Ito cell atrophy and lesion severity across the doses (Filgo et al. 2015). Since Ito cells accumulate fat in the liver sinusoids, this observation provides additional support for hepatic steatosis as a condition of concern following developmental PFOA exposure. There was an increase in severity with dose for the Ito cell fat deposits for all but the high-dose group. The Ito cell lesion was present in the SV-129 mice, but was not associated with tumors. CD-1 mice had a significant increase in Ito cell hypertrophy at 5 mg/kg/day compared to controls, but there was a lack of dose-response. The authors concluded that liver damage from PFOA exposure occurring early in development is not totally linked to PPAR- α and could progress as animals aged without continued dosing, thus compromising liver function and possibly leading to tumor development.

Inhalation and Dermal Exposures

No data on the tumorigenic effects of chronic inhalation or dermal exposures to PFOA were identified in the literature.

3.3 Other Key Data

3.3.1 Mutagenicity and Genotoxicity

PFOA has been tested for genotoxicity in a variety of *in vivo* and *in vitro* assays. The data from the *in vitro* studies are summarized in Table 3-32.

PFOA was tested in a cell transformation and cytotoxicity assay conducted in C₃H10T_{1/2} mouse embryo fibroblasts. The cell transformation was determined as both colony transformation and foci transformation. There was no evidence of transformation at any of the dose levels tested in either the colony or foci assay methods (Garry and Nelson 1981).

PFOA was tested twice (Lawlor 1995, 1996) for its ability to induce mutation in the *Salmonella* – *E. coli*/mammalian-microsome reverse mutation assay. The tests were performed both with and without metabolic activation. A single positive response seen in *S. typhimurium* TA1537 when tested without metabolic activation was not reproducible. PFOA did not induce mutation in either *S. typhimurium* or *E. coli* when tested either with or without metabolic activation. PFOA did not induce chromosomal aberrations in human lymphocytes when tested with and without metabolic activation up to cytotoxic concentrations (Murli 1996a; NOTOX 2000). Sadhu (2002) reported that PFOA did not induce gene mutation when tested with or without metabolic activation in the K-1 line of CHO cells in culture.

Table 3-32. Genotoxicity of PFOA *In Vitro*

Test System	End-point	With Activation	Without Activation	Reference
C ₃ H10T _{1/2} mouse embryo fibroblasts	Cell Transformation	NA	-	Garry and Nelson 1981
C ₃ H 10T _{1/2} mouse embryo fibroblasts	Cytotoxicity	NA	-	Garry and Nelson 1981
<i>S. typhimurium</i> TA1537	Gene Mutation	-	+ (not reproducible)	Lawlor 1995, 1996
<i>E. coli</i>	Gene Mutation	-	-	Lawlor 1995, 1996
CHO cells	Chromosomal Aberrations	+, +	+, -	Murli 1996b, 1996c
CHO cells	Polyploidy	+, +	+, -	Murli 1996b, 1996c
Human lymphocytes	Chromosomal Aberrations	-	-	Murli 1996c; NOTOX 2000
K-1 CHO cells	Gene Mutation	-	-	Sadhu 2002
<i>S. typhimurium</i> TA98, TA100, TA102, TA104	Gene Mutation	-	-	Freire et al. 2008

Note: NA= not applicable.

Murli (1996b, 1996c) tested PFOA twice for its ability to induce chromosomal aberrations in CHO cells. In the first assay, PFOA induced both chromosomal aberrations and polyploidy in both the presence and absence of metabolic activation. In the second assay, no significant increases in chromosomal aberrations were observed without activation. However, when tested with metabolic activation, PFOA induced significant increases in chromosomal aberrations and in polyploidy (Murli 1996b). The effects were observed only at toxic concentrations (EFSA 2008).

PFOA did not display mutagenic activity with or without metabolic activation in *S. typhimurium* strains TA98, TA100, TA102, or TA104 (Freire et al. 2008).

The data summarized in Table 3-32 suggest that PFOA is not a mutagen. A single positive result in *S. typhimurium* was not reproducible by the same authors and was not replicated in other studies. Potential chromosomal effects were found in CHO cells at toxic concentrations, but not in human lymphocytes.

Governini et al. (2015) collected semen samples from 59 healthy nonsmoking patients attending a Center for Couple Sterility conference at the University in Siena, Italy. The subjects were divided into those that were normozoospermic (13) and those that were oligoasthenoteratozoospermic (46). PFOA was present in 75% of the seminal plasma samples and only 16% of the blood samples. Conversely, PFOS was present in 25% of the seminal plasma samples and 84% of the serum samples. Sperm were evaluated for the presence of aneuploidy and diploidy, and sperm DNA was evaluated for fragmentation using the terminal deoxynucleotidyl transferase dUTP nick end labeling (TUNEL) assay. The frequencies of aneuploidy and diploidy were significantly greater in the PFAS-positive samples than in the PFAS-negative samples ($P < 0.001$ and $P < 0.05$, respectively), suggesting the possibility for errors in cell division. The levels of fragmented chromatin were significantly increased ($P < 0.001$) for the PFAS-positive group compared with the PFAS-negative group.

PFOA was tested twice in the *in vivo* mouse micronucleus assay. PFOA did not induce any significant increases in micronuclei and was considered negative under the conditions of this assay (Murli 1995, 1996d).

G. Zhao et al. (2010) used A_L cells to determine the mutagenicity of PFOA to mammalian cells. A_L cells are a human-hamster hybrid containing CHO-K1 chromosomes and a single copy of human chromosome 11. The significance of human chromosome 11 is that it encodes for expression of the human cell surface protein CD59. A_L and mitochondria-deficient A_L cells were incubated with 0, 1, 10, 100, and 200 μmol PFOA for up to 16 days and used in the 3-(4,5-dimethylthiazol-2-yl)-2,5-diphenyltetrazolium bromide (MTT) viability, mutation, or caspase assays. Reactive oxygen species (ROS), nitric oxide, and superoxide anion production were measured in the cells, and the effects of ROS/reactive nitrogen species quenchers [0.5% dimethyl sulfoxide (DMSO) and 0.2 mM NG-methyl-L-arginine, respectively] on mutagenicity and caspase activities were determined. At 100 and 200 μmol PFOA, A_L cell viability was significantly decreased after incubation for 1, 4, 8, and 16 days. CD59 mutation frequencies were increased in A_L cells after a 16-day incubation with 200 μmol PFOA. There was no increase in mutations in mitochondria-deficient A_L cells after incubation with 100 or 200 μmol PFOA.

Production of ROS, nitric oxide, and superoxide anion was significantly increased at 100 and 200 μmol PFOA after incubation of A_L cells for 1, 4, and 16 days. Incubation with DMSO to inhibit ROS production significantly decreased the CD59 mutation frequency caused by 200 μmol PFOA after the 16-day incubation. In contrast, mitochondria-deficient A_L cells had no increase in ROS or superoxide production after incubation with up to 200 μmol PFOA for 16 days.

To assess whether PFOA could induce the apoptotic pathway, caspase-3/7 and caspase-9 were examined in intact A_L cells (mitochondria-deficient cells were not examined). The highest concentration significantly increased caspase 3/7 and 9 activities after 1- and 4-day incubations. Incubation with 0.5% DMSO and 0.2 mM NG-methyl-L-arginine significantly decreased the increased caspase activity induced by 200 μmol PFOA. The results led the authors to suggest that mitochondrial-dependent ROS might play an important role in PFOA-induced mutagenicity and that induction of caspase activities might be mediated by reactive oxygen and nitrogen species.

3.3.2 Immunotoxicity

The impact of PFOA on the immune system has been the subject of considerable research, primarily in mice. A number of the early studies by Yang et al. (2000, 2001, 2002a) used high-dose exposures of 0.02% to 0.05% PFOA. Later studies by DeWitt et al. (2008, 2009, 2015) and Loveless et al. (2008) used a range of doses from < 1 mg/kg/day to 30 mg/kg/day. Most of the studies focused on responses associated with the spleen and thymus. Some of the effects observed were PPAR α -associated, but others are totally or partially independent. There is evidence for full or partial reversal of effects in those studies that incorporated a recovery phase. One study of immunotoxicity used the dermal route of exposure (Fairley et al. 2007).

Rat. Loveless et al. (2008) administered 0, 0.3, 1, 10, and 30 mg linear PFOA/kg by oral gavage to groups of male CD rats (n = 10 per group) for 29 days. The animals received a dose of SRBC on day 23. A separate group of high-dose rats were injected with water instead of SRBC. Rat body weight was recorded on days 0, 3, and 6–28. At necropsy, blood was collected for evaluation of immune system parameters. Cell counts were determined for the thymus and

spleen. Total spleen and thymocyte cell counts and organ weights in exposed rats were comparable to control. Microscopic examination of the thymus, mesenteric lymph nodes, and popliteal lymph nodes revealed no effects in treated rats resulting from PFOA exposure. There was no difference observed in immunoglobulin (IgM) titers between treated and control rats. The immunological NOAEL was 30 mg/kg/day.

Mouse. Yang et al. (2000, 2001, 2002a, 2002b) completed a series of studies investigating the immunotoxic effects of PFOA. In the first study, Yang et al. (2000) examined the liver, spleen, and thymus effects of several known PPAR α activators, including PFOA. The researchers administered 0.02% PFOA (~40 mg/kg/day) to male C57BL/6 mice in the diet for 2, 5, 7, and 10 days. At the end of the feeding period, mice were sacrificed and the liver, spleen, and thymus were weighed. Administration of PFOA resulted in a significant increase in liver weight relative to control even at day 2. Following 5 days of administration, significant decreases in thymus and spleen weight were noted.

A second component of the Yang et al. study (2000) examined the effect of 0.02% PFOA in the diet on the cellularity, cell surface phenotype, and cell cycle of thymocytes and splenocytes. After 7 days, significant decreases in the total number of thymocytes (85%) and splenocytes (80%) were observed. There is a pattern to the development of thymocytes that should be considered when evaluating the impact of chemicals on their differentiation. Early thymocytes formed in the bone marrow do not express CD4 or CD8 (CD4⁻CD8⁻). In the thymus, they differentiate and express both CD4 and CD8 (CD4⁺CD8⁺). They also undergo proliferation and downregulation of either the CD4 or CD8 protein expression to become either a CD4 or CD8 thymocyte (Yang et al. 2000). Following exposure to PFOA, the number of thymocytes expressing neither CD4 nor CD8 decreased by 57%; the number expressing both CD4 and CD8 decreased by 95%; the number expressing only CD4 decreased by 64% while those expressing only CD8 decreased by 72%. As detected by cell cycle flow cytometry analyses, thymocyte proliferation was inhibited based on the number of cells in each stage of the cell cycle.

T-cells (CD3⁺) and B-cells (CD19⁺) in the spleen decreased by 75% and 86%, respectively. Splenic T-cells are lymphocytes produced in the thymus that carry the CD3⁺ surface protein marking them as T-cells for exportation to the spleen. There are several classes of T-cells that are characterized by surface proteins. Yang et al. (2000) found significant decreases in helper CD3⁺T-cells with CD4⁺ surface proteins (78%) and cytotoxic CD3⁺T-cells with CD8⁺ surface proteins (74%). The authors suggested that, unlike the CD3⁺T-cells that originate in the thymus, the decrease in CD19⁺B-cells of the spleen reflects decreased differentiation and maturation in the bone marrow where they are formed.

In the final phase of the Yang et al. study (2000), the effects of *in vitro* exposure of thymocytes and splenocytes to PFOA were examined. The *in vitro* studies showed spontaneous apoptosis occurring in splenocytes and thymocytes after 8 or 24 hours of culturing in the presence of varying concentrations of PFOA (50, 100, and 200 μ mol). However, under the exposure conditions, PFOA did not appear to significantly alter the cell cycle. The only dose tested (~40 mg/kg/day) was a LOAEL for its effects on the immunoactive products of the thymus and spleen. Recovery can occur with the cessation of exposure as illustrated by the Yang et al. study (2001) described below.

Yang et al. (2001) reported on their examination of the immunosuppressive effects of PFOA. As was the case in their earlier publication (Yang et al. 2000), the 2001 report includes several components. A diet of 0.02% PFOA (~40 mg/kg/day) was fed to C57BL/6 mice for 2–10 days.

One group of animals was exposed to PFOA each day until day of sacrifice on days 2, 5, 7, and 10. At sacrifice, body, liver, and spleen weights were recorded. A second group of animals was dosed according to the same schedule, but dosing ceased after day 7, and the animals were fed normal diets for 2–10 days to monitor recovery from the effects of exposure. In the recovery group, animals were sacrificed after 2-, 5-, and 10-day recovery periods.

The mice that received 0.02% PFOA for up to 10 days experienced significant increases in liver weight compared to controls beginning at day 2. Significant decreases in thymus and spleen weights were observed starting on day 5. Body weight increased for the first 2 days of the study and decreased continuously for the remainder of the exposure period. The activity of palmitoyl-CoA and lauryl-CoA, biomarkers for PPAR α activation and peroxisome proliferation, also were increased significantly and increasingly across the exposure period. The impact of PFOA exposure was similar to that observed in the Yang et al. study (2000). After administration for 7 days, the number of thymocytes expressing neither CD4 nor CD8 decreased by 65% following exposure to PFOA; the number expressing both CD4 and CD8 decreased by 95%; and the number expressing either CD4 or CD8 decreased by 65% and 75%, respectively. T-cell (CD3⁺) splenocytes and B-cell (CD19⁺) splenocytes decreased by 65% and 75%, respectively. As detected by cell cycle flow cytometry analyses, thymocyte but not splenocyte proliferation was inhibited.

The animals that participated in the recovery portion of this study rapidly regained their body weight starting on the second day after withdrawal of PFOA. However, the liver weight failed to recover even after 10 days. Thymus weight recovery started on day 2 and was completed by day 10. The spleen weights returned to normal by day 2 post-withdrawal. The increases in thymus and spleen weight during recovery were paralleled by increases in total thymocyte and splenocyte counts. Thymocyte recovery was apparent on day 5 and complete by day 10, although during the first two days of the recovery period, further decreases in the CD4⁺CD8⁺, CD4⁺ and CD8⁺ cells were observed. Flow cytometry evaluation of the distribution of the cells across the cell cycle in the recovery group animals demonstrated increases in cell proliferation following removal of PFOA from the diet. However, final cell counts did not reach the control values for the thymocyte (CD4⁺ and CD8⁺) or splenocyte (CD3⁺ and CD19⁺) populations evaluated.

In the second component of the Yang et al. study (2001), C57BL/6 mice were administered diets consisting of 0.001%–0.05% PFOA (w/w) for 10 days. These doses are equivalent to approximately 2.0–100 mg/kg/day. There was a dose-related decrease in spleen and thymus weights and a dose-related increase in liver weights accompanied by a corresponding increase of palmitoyl-CoA and lauryl-CoA activity. Enzyme activity was significantly increased for all doses. Spleen and thymus weights were significantly decreased at doses \geq 0.01% and higher but not at the lower doses; the increases in liver weights were significantly increased for the 0.02% and 0.05% doses. With the testing of a broader range of doses, ~20 mg/kg/day was found to be a LOAEL for effects on the thymus and spleen and the ~6 mg/kg/day dose a NOAEL.

Yang et al. (2002a) examined the possible involvement of PPAR α in the immunomodulation exerted by PFOA. This study made use of transgenic PPAR α -null mice (Sv/129), which are homozygous with regards to a functional mutation in the PPAR α gene. These mice do not exhibit peroxisome proliferation or hepatomegaly and hepatocarcinogenesis even after exposure to peroxisome proliferators. The mice were fed a diet consisting of 0.02% PFOA (w/w) (~40 mg/kg/day) for 7 days. At the end of the feeding period, mice were sacrificed and the liver, spleen, and thymus were removed and weighed. The effect of PFOA on peroxisome proliferation, cell cycle, and lymphoproliferation was ascertained.

The results showed that, in contrast to wild-type mice, feeding PPAR α -null mice PFOA resulted in no significant decrease in body weight. Liver weight in PPAR α -null mice fed the PFOA diet was significantly increased when compared to control PPAR α -null mice, but not when compared to wild-type PFOA-exposed mice. Peroxisome proliferation, as measured by fatty acid oxidation, was totally lacking in PPAR α -null mice. Also, in contrast to wild-type mice, feeding PPAR α -null mice PFOA resulted in no significant decrease in the weight of the spleen or the number of splenocytes.

There was a decrease in weight and cellularity of the thymus in the PPAR α -null mice compared to the PPAR α -null control mice, but it was not as dramatic as that in the PFOA-exposed wild-type mice. In addition, the decreases in the size of the CD4+CD8+ population of thymus cells and the number of thymus cells in the S and G2/M phases of the cell cycle were lower in PPAR α -null mice than they were in the PFOA-exposed wild-type mice, but higher than in the PPAR α -null control mice. PFOA treatment caused no significant change in splenocyte proliferation in PPAR α -null mice in response to mitogen exposure, but did show a response in the PFOA-exposed wild-type mice as described above.

The series of studies published by Yang et al. (2000, 2001, 2002a) link many of the effects of the liver, thymus, and spleen in PFOA-exposed mice to the activation of PPAR α . However, there were some impacts on the thymus and liver that were independent of PPAR α receptor activation. PPAR α -null mice still showed increases in liver weight and effects on the thymus (small decrements in organ weight, thymocyte cellularity, and proliferative cell cycle) following a 7-day exposure to approximately 40 mg/kg/day PFOA that were independent of PPAR α .

Yang and colleagues extended their studies of the immunotoxicity of PFOA in a feeding study designed to examine the effects of PFOA on specific humoral immune responses in mice (Yang et al. 2002b). For this study, 0.02 % PFOA was administered to male C57BL/6 mice for 10 days. The animals were then evaluated via plaque-forming cell (PFC) and serum antibody assays for their ability to generate an immune response to horse red blood cells (HRBCs). *Ex vivo* and *in vitro* splenic lymphocyte proliferation assays also were performed. The results showed that mice fed normal chow had a strong humoral response to challenge the HRBCs, as measured by the PFC assay. In contrast, mice fed PFOA responded to HRBC immunization with no increase in HRBC-specific PFCs, relative to unimmunized controls. However, in experiments where PFOA-treated mice received normal chow following HRBC immunization, there was a significant recovery of the numbers of specific PFCs stimulated. The suppression of the humoral immune response by PFOA was confirmed by analysis of the serum anti-HRBC response.

In *ex vivo* experiments, splenocytes isolated from control mice responded to both concanavalinA (ConA) and lipopolysaccharide (LPS) with lymphocyte proliferation, as measured by thymidine incorporation. However, treating mice with 0.02% PFOA for 7 days attenuated the proliferation. In a set of *in vitro* experiments, PFOA (1–200 μ mol) added to the culture medium of splenocytes cultured from untreated mice did not cause an alteration of lymphocyte proliferation in response to LPS or ConA.

DeWitt et al. (2008) expanded the repertoire of studies of the immunological effects of PFOA by examining various aspects of humoral (antibody production) and cellular immunity. The first component of their publication had many similarities with the Yang et al. study (2001). Adult female C57BL/6J mice (n = 40 per endpoint and 8 per group) were exposed to a single daily dose of 30 mg PFOA/kg/day in distilled water by gavage for 10 continuous days. After 10 continuous days of exposure, half of the mice continued receiving PFOA from day 11 through

day 15 (constant group) while the other half received distilled water from day 11 through day 15 (recovery group). On day 11, 16 mice per group were immunized with sheep red blood cells (SRBC) and eight mice per group were injected with BSA. Sacrifices took place on day 16 (1 day postexposure period) and day 31 (15 days postexposure period). Vehicle and cage controls also were included in the study. All groups were monitored for the following effects:

- Body weight and organ weights (day 16, day 31)
- Serum IgM levels (day 16)
- Delayed-type hypersensitivity (DTH) foot-pad response to BSA (day 26)
- Serum IgG levels after booster immunization with SRBC on day 20 (day 31)

The results for body and organ weights were comparable to those in the Yang et al. study (2001). Body weight was significantly decreased from days 8–11 for both PFOA-treated groups and on day 16 for mice in the constant exposure group. By day 31, there were no body weight differences between the groups. Relative liver weight was significantly elevated in both PFOA-treated groups on days 16 and 31. Absolute and relative spleen and thymus weights of animals in both PFOA groups were significantly decreased compared to control groups on day 16. By day 31, thymus and spleen weights were not statistically different between control and treated mice. IgM levels following immunization with SRBC were reduced by up to 20% compared to controls on postexposure day 1 in both the recovery and constant exposure groups. There were no significant differences from controls for SRBC-specific IgG levels and for DTH foot-pad responses to the BSA challenge.

The C57BL/6 mice used for the continuous-dosing versus recovery component of the DeWitt et al. study (2008) were found to develop ulcerative dermatitis following the PFOA exposure. It was determined that this effect was a genetic susceptibility in the strain, and they were not used for the dose-response component of the study; the C57BL/6N strain was used in its place.

Two studies of dose-response were included in the DeWitt et al. (2008) publication. Groups of 16 female C57BL/6N mice were given 0, 3.75, 7.5, 15, and 30 mg PFOA/kg/day in the drinking water for 15 days during the first experiment. In the second experiment, the doses were 0, 0.94, 1.88, 3.75, and 7.5 mg PFOA/kg/day administered for 15 days in the drinking water. The immunological sensitization and postdose monitoring were identical to that used in the constant-dosing versus recovery experiment.

In the first experiment, body weight was significantly decreased from day 8–16 at 30 mg/kg PFOA and on day 16 at 15 mg/kg PFOA. As observed previously, liver weights were significantly elevated at day 16 and day 31 at all doses. Absolute and relative spleen and thymus weights were significantly decreased at ≥ 15 mg/kg PFOA on day 16. With the exception of the absolute thymus weight at 15 mg/kg PFOA, all spleen and thymus weights were similar to weights in controls 15 days after dosing. The IgM response to SRBC was significantly reduced at ≥ 3.75 mg/kg PFOA in a direct dose-related manner. The IgG response to SRBC challenge was slightly but significantly elevated at 3.75 and 7.5 mg/kg PFOA but similar to that of the control level at the higher doses. Thus, there was a direct response of IgM, but not IgG, to dose across the dose levels. There was no significant change in the DTH response at any dose. The LOAEL from the first experiment was 3.75 mg/kg/day dose based on decreased IgM and increased IgG response to SRBC immunization and increased liver weights ($p < 0.05$).

The second dose-response experiment confirmed the 3.75 mg/kg/day dose as the immunological LOAEL on the basis of significantly decreased spleen weight, decreased IgM

levels on day 16, and increased IgG levels on day 31. The immunological NOAEL was 1.88 mg/kg/day. BMD analysis of IgM serum titer data gave a lower bound 95% confidence limit of 1.75 mg/kg/day on a BMD (one SD) of 3.06 mg/kg/day. Liver weight was significantly increased at all doses on days 16 and 31. The LOAEL for increased liver weight was 0.94 mg/kg PFOA.

As mentioned earlier, some of the immunological responses observed in the studies of immunotoxicity are linked to PPAR α activation by PFOA. DeWitt et al. (2015) published results for a study in female PPAR α KO mice (B6.129S4-*Ppar*^{tm1Gonz}N12 mice) and compared them to the response of female C57BL/6-Tac wild-type mice. Both T-cell-dependent and T-cell-independent antibody production were evaluated. The doses used in the study of the T-cell-dependent responses were 0, 7.5, and 30 mg PFOA/kg/day dissolved in deionized drinking water for 14 days. On day 11, the animals were injected with SRBCs to stimulate an immune response. PFOA dosing continued for 4 more days (15 days dosed); the following day, the animals were sacrificed. Body weight was significantly decreased only in wild-type mice at 30 mg/kg/day. Relative spleen weights were significantly decreased ($P < 0.05$) in the wild-type but not the KO mice at 30 mg/kg/day of PFOA. Relative thymus weights were significantly decreased in the wild-type mice at 7.5 mg/kg/day, but not in the KO mice at either dose or the wild-type mice receiving 30 mg/kg/day. There was a significant ($P < 0.05$) reduction in the IgM antibody response to the SRBC injection at 30 mg/kg/day for both the wild-type and KO animals ($n = 6$), indicating that the response was not totally related to PPAR- α activation. The NOAEL in wild-type and KO animals was 7.5 mg/kg/day and the LOAEL 30 mg/kg/day based on decreased T-cell-dependent IgM antibody response to SRBC.

To evaluate T-cell-independent responses to PFOA, groups of eight C57BL/6N mice were given doses of 0, 0.94, 1.88, 3.75, and 7.5 mg/kg/day in their drinking water. On day 11, they were injected with the T-cell-independent antigen dinitrophenyl ficol. At sacrifice (day 16), blood was collected for analysis of IgM antibody titers. There was a significant decrease ($p < 0.05$) in the antibody response by 9.4–10.7% in the animals receiving doses ≥ 1.88 mg/kg/day of PFOA. The NOAEL for the T-cell-independent response to dinitrophenyl ficol was 0.94 mg/kg/day of PFOA and the LOAEL was 1.88 mg/kg/day. Thus, suppression of the T-cell-independent response occurred at a lower dose (1.88 mg/kg/day) than the dose resulting in suppression of the T-cell-dependent response (7.5 mg/kg/day).

The authors looked at changes in lymphocyte populations at 10, 13, and 15 days of exposure in the female C57BL/6N mice and saw no significant dose-dependent changes in lymphocyte cell types. They concluded that both sets of responses were due to changes in cellular function rather than lymphocytotoxicity (DeWitt et al. 2015).

Loveless et al. (2008) administered 0, 0.3, 1, 10, and 30 mg linear PFOA/kg by oral gavage to groups of male CD-1 mice ($n = 20$ per group) for 29 days. The animals received a dose of SRBC on day 24. A separate group of high-dose mice was injected with water instead of SRBC. Mice were weighed daily. At necropsy, blood was collected for evaluation of immunity parameters. Cell counts were determined for the thymus and spleen.

Absolute and relative spleen and thymus weights were significantly decreased at ≥ 10 mg/kg/day. The relative spleen weight of mice dosed with 1 mg/kg/day also was significantly decreased compared to control animals. Spleen and thymus cell counts were significantly decreased and minimal to severe lymphoid depletion/atrophy of the thymus was observed at ≥ 10 mg/kg/day. IgM titers were significantly decreased at ≥ 10 mg/kg/day. Serum

CORT was significantly increased at 10 mg/kg/day and elevated (not statistically significant) at 30 mg/kg/day. When IgM and CORT were plotted against each other, a negative correlation coefficient suggested that increasing CORT levels decreased the ability to make SRBC antibody. The LOAEL was 1 mg/kg/day based on decreased spleen weight, and the NOAEL was 0.3 mg/kg/day. Mice appeared to be more susceptible than rats to immunosuppression from PFOA.

Loveless et al. (2008) hypothesized that at least a portion of the thymic response to PFOA might be related to physiological stress and increased levels of CORT hormones. DeWitt et al. (2009) investigated this hypothesis by comparing the immunological response of adrenalectomized (ADX) C57BL/6N female mice to that of sham-operated female mice from the same strain. The animals were dosed with 0, 3.75, 7.5, and 15 mg PFOA/kg/day in the drinking water for 10 days. Body weight was recorded on dosing days 0, 4, and 8, plus 2 and 5 days postdosing. On exposure days 5 and 10, blood and serum were collected for analysis of a broad array of clinical chemistry parameters, including activity of liver enzymes indicative of cellular damage (e.g., ALP, AST, ALT, LDH, GGT, and SDH), serum lipids (cholesterol and triglycerides), and CORT. A baseline measure of CORT was determined from serum samples collected before dosing began. One day after cessation of exposure, the mice were immunized with SRBC. Four days later, serum was collected and the levels of CORT and IgM were determined.

Body weight in the sham-operated mice declined during dosing in the highest dose group but recovered by 5 days postdosing. In the ADX mice, body weight declined during dosing at 7.5 and 15 mg PFOA/kg/day, but recovered in mice receiving 7.5 mg PFOA/kg/day by 5 days postdosing. There were significant increases in ALT, AST, LDH, and SDH at the highest dose for the ADX mice indicative of damage to hepatic cell membranes (Table 3-33).

Serum levels of triglycerides significantly decreased compared to controls, with all doses for the sham-operated mice on day 5 of dosing but only for the 7.5- and 15-mg/kg/day doses in the ADX mice. Cholesterol levels were significantly decreased ($p < 0.05$) in the sham-operated mice at the highest dose, but no differences in cholesterol levels were observed in the ADX mice.

Table 3-33. Selected Clinical Chemistry Parameters in Mice Treated with PFOA for 5 Days

Dose (mg/kg/day)	ALT	AST	LDH	SDH
Sham-Operated				
0	39.52±2.50	121.56±17.96	320.57±29.84	46.43±1.03
3.75	43.88±0.93	104.07±10.24	293.92±68.65	39.31±3.32
7.5	56.96±6.78	95.55±10.22	262.71±35.60	39.02±7.77
15	62.57±3.15	89.07±1.30	191.76±22.25	46.87±1.46
ADX				
0	26.96±1.78	73.53±4.70	176.50±19.32	33.05±1.58
3.75	29.67±1.62	76.58±3.38	222.69±19.18	37.95±2.35
7.5	39.04±2.59	83.79±8.94	320.45±53.34	46.35±1.42
15	94.23±31.66*	126.47±16.39*	435.57±81.42*	77.61±19.89*

Source: DeWitt et al. 2009

Note: * = $p < 0.05$ versus corresponding sham control or ADX control group.

After 10 days, there were no significant differences in liver enzymes for the ADX or sham mice. However, there was a dose-related trend towards increased levels of liver enzymes for the PFOA-exposed sham-operated animals and for LDH in the PFOA-exposed ADX animals (Table 3-34).

Table 3-34. Selected Clinical Chemistry Parameters in Mice Treated with PFOA for 10 Days

Dose (mg/kg/day)	ALT	AST	LDH	SDH
Sham-Operated				
0	51.51±14.62	93.30±6.33	333.48±86.86	54.60±16.72
3.75	79.26±33.87	123.73±15.20	404.14±59.89	45.50±10.15
7.5	135.57±38.18	142.66±15.59	490.44±69.14	80.71±14.59
15	344.53±235.63	242.92±117.62	595.01±137.37	89.20±26.03
ADX				
0	128.22±24.80	106.00±8.86	236.96±30.23	61.88±8.87
3.75	282.23±193.54	217.10±3.48	379.61±80.67	68.78±24.88
7.5	89.79±21.54	99.78±12.59	574.65±236.38	52.07±11.98
15	261.14±75.95	181.40±32.94	614.05±144.95	101.93±24.00

Source: DeWitt et al. 2009

At the end of dosing, corticosteroid levels in the sham-operated animals were greatly elevated compared to the levels in the control animals at all doses, and the difference was statistically significant at the highest dose. By 5 days postdosing, the CORT levels had declined for all doses but were still elevated compared to controls for the 7.5- and 15-mg/kg/day groups. In the animals lacking their adrenal glands, there were no statistically significant differences in the hormone levels. IgM levels were significantly lower than controls at the highest dose for the sham-operated animals and at the two highest dose groups for the ADX mice. However, when comparing the sham mice to the ADX mice, the only significant difference in IgM was found for the 7.5-mg/kg/day animals. On the basis of data, it appears that stress-related CORT production did not have a major impact on the IgM response to the SRBC inoculation.

Son et al. (2009) administered 0, 2, 10, 50, and 250 ppm PFOA (equivalent to 0, 0.49, 2.64, 17.63, and 47.21 mg/kg PFOA) in the drinking water to 4-week-old male ICR mice for 21 days to determine if PFOA alters T lymphocyte phenotypes and cytokine expression in mice. The spleen, thymus, and trunk blood were collected at sacrifice. Sections of the spleen and thymus were processed for histological examination. Splenic and thymic expression of mRNA from proinflammatory cytokines—including tumor necrosis factor- α , interleukin-1 β , and interleukin-6, and the proto-oncogene c-myc—were analyzed using RT-PCR. Flow cytometry was used to phenotype the splenic and thymic lymphocyte populations.

Spleen and thymus weights were slightly decreased in mice treated with PFOA. Enlargement with marked hyperplasia of the white pulp and increased cellular density of the lymphoid follicles were observed in spleens at 250 ppm. In the thymus, decreased cortex and medulla thickness and densely arranged cortex lymphoid cells were observed at 250 ppm. Tumor necrosis factor- α , interleukin-1 β , interleukin-6, and c-myc expression were significantly elevated at 250ppm in the spleen. Interleukin-1 β expression also was elevated at 50 ppm in the spleen. In the thymus, c-myc expression was significantly elevated by treatment with 50 and 250 ppm PFOA.

The splenic and thymic lymphocyte population was altered by PFOA treatment, as shown in Table 3-35. A 50% decrease was observed in splenic CD8⁺ lymphocytes at all PFOA doses, and increases in splenic CD4⁺ lymphocytes of 43% and 106% at 50 and 250 ppm PFOA, respectively, were observed. In the thymus, a 110% increase was observed in thymic CD8⁺ lymphocytes at 250 ppm, but thymic CD4⁺ lymphocyte populations were not affected and CD4⁺CD8⁺ populations were decreased at 50 and 250 ppm PFOA. The lowest dose tested (0.49 mg/kg/day) was a LOAEL for CD4⁺ and CD8⁺ splenocytes.

Table 3-35. Impact of PFOA on Splenic and Thymic Lymphocyte Populations

	Dose (mg/kg/day)			
	0.49	2.64	17.63	47.21
Spleen				
CD4 ⁻ CD8 ⁻	↑	-	-	↓
CD4 ⁺ CD8 ⁻	-	-	↑	↑
CD4 ⁻ CD8 ⁺	↓	↓	↓	↓
CD4 ⁺ CD8 ⁺	↓	↓	-	-
Thymus				
CD4 ⁻ CD8 ⁻	-	-	-	↑
CD4 ⁺ CD8 ⁻	-	-	-	-
CD4 ⁻ CD8 ⁺	-	-	-	↑
CD4 ⁺ CD8 ⁺	-	-	↓	↓

Source: Son et al. 2009

Notes:

↑ Significantly increased compared to control (p < 0.05).

↓ Significantly decreased compared to control (p < 0.05).

- Not significantly different from control.

Qazi et al. (2009) investigated the impact of PFOA on the innate immune system. Adult male C57BL/6 (H-2^b) mice were administered 0.001% and 0.02% PFOA (~2 or 40 mg/kg) in the diet (w/w) for 10 days. After the last dose, all mice were sacrificed. Sacrifice was delayed for a subset of the animals until 2 hours after they had received an LPS injection to stimulate an immunological response. Blood, peritoneal exudate cells, liver, epididymal fat, spleen, thymus, and bone marrow were recovered. The blood, peritoneal exudate, bone marrow, and spleen were evaluated for total and differential white blood cell counts and concentrations of tumor necrosis factor (TNF- α) and interleukin 6 (IL-6).

Consistent with other studies of the 0.02% dose, there was a significant increase in liver weight after the 10-day exposure. Body weight, thymus weight, spleen weight, and epididymal fat depots were decreased. Food consumption in these animals was reduced by 35%, which might have played a role in the reduced body, organ, and tissue weights. Compared to the controls, there was a significant decrease in total white cells, lymphocytes, and neutrophils at 0.02% PFOA. This same dose was associated with a decrease in total white cell count in bone marrow and spleen, and an increase in the proportion found as macrophages in the bone marrow, spleen, and peritoneal cavity. Although the total number of macrophages was not reduced in the peritoneal cavity and spleen, it was reduced in the bone marrow. The increase in the proportion of macrophages reflects a decrease in other white cell populations. There was significant increase in the concentration of IL-6 in all of the 0.02 % dosed animals, but only those receiving the LPS injections showed a significant increase in TNF- α . The 0.001% dose (about 2 mg/kg/day) was a NOAEL.

The data available on immunological responses of animals following oral exposure to PFOA are extensive, especially as they apply to mice. A number of the studies used doses of about 40 mg/kg/day. However, studies conducted at lower doses find effects on the spleen and/or thymus at doses from 0.5 to 2 mg/kg/day. Activation of PPAR α appears to augment the response based on studies in PPAR α -null mice but is not necessary (Yang et al. 2002a). There are differences between mice and rats with mice showing a response at a lower dose (Loveless et al. 2008). Cessation of dosing can reverse some of the observed effects in mice (Yang et al. 2001).

Inhalation Exposure

No data on the effects of inhalation exposure on immunological endpoints were identified in the literature.

Dermal Exposure

Fairley et al. (2007) carried out a complex study of toxicity and respiratory hypersensitivity to ovalbumin (OVA) as impacted by dermal exposure to PFOA dissolved in acetone compared to acetone alone. There were several phases to the study. In the first phase, a range-finding study, PFOA was applied to each ear of female BALB/c mice (n = 5 per group) at doses of 0, 0.01%, 0.1%, 0.25%, 0.5%, 1.0%, and 1.5% PFOA (equivalent to 0, 0.25, 2.5, 6.25, 12.5, 25, and 50 mg/kg/day) for 4 days. Six days after last inoculation, the animals were sacrificed. The liver, spleen, and thymus were recovered and weighed. A significant increase in liver weight was observed at ≥ 6.25 mg/kg PFOA. Spleen weight was significantly decreased in mice dosed with 25 mg/kg and 50 mg/kg PFOA, and thymus weight was significantly decreased in mice at the highest dose ($p < 0.05$). The cell counts in the spleen were significantly decreased compared to control at all doses and for the highest two doses in the thymus. The LOAEL was 6.25 mg/kg/day based on a statistically significant increase in liver weight ($p < 0.01$), and the NOAEL was 2.5 mg/kg/day.

In the second phase of the Fairley et al. study (2007), groups of 5–15 animals were dosed dermally on the ears for 4 days with doses of 0, 0.5%, 0.75%, 1.0%, and 1.5% PFOA (equivalent to 0, 12.5, 18.75, 25, and 50 mg/kg/day). On days 1 and 10, they were injected i.p. with either 2.0 mg alum or 7.5 μ g OVA and 2.0 mg alum in a phosphate-buffered saline solution (100 μ L). Four days after the last inoculation, the animals were sacrificed and blood was collected by cardiac puncture. Liver, spleen, and thymus were recovered and weighed; spleen and thymus cellularities were determined. A significant ($p < 0.01$) increase in liver weight and decrease in spleen weight and spleen cellularity occurred at all doses. Thymus weight and cellularity were significantly decreased ($p < 0.01$) at ≥ 18.75 and ≥ 25 mg/kg/day, respectively. There were no significant differences in the CD4⁺, CD8⁺, CD4⁺8⁺, or CD3e T-cells. CD3e protein is expressed by both thymocytes and mature T-cells.

Levels of IgE and OVA-specific IgE were measured in the control and dosed animals by enzyme-linked immunosorbent assay. IgE is the immunoglobulin that is best correlated with respiratory allergic responses. It functions to stimulate mast cells and basophils to release histamine and other mediators of inflammation (Saladin 2004). The IgE response was increased in a dose-related fashion compared to the OVA control for all the PFOA-treated animals; the increase was significant ($p < 0.05$ or 0.01) at doses ≥ 18.75 mg/kg/day. The OVA-specific IgE response did not demonstrate a direct response to dose, but there was a significant increase ($p < 0.05$) for the 18.75- and 25-mg/kg/day groups. The OVA-specific response for the three highest dose groups was practically indistinguishable from the OVA control.

The dermal LOAEL was 12.5 mg/kg/day based on increased liver weight and decreased spleen weight and cellularity. No NOAEL was established.

In the third part of the Fairley et al. study (2007), mice (n = 5) were dosed dermally via their ears for 4 days as described above (0, 12.5, 18.75, 25, and 50 mg/kg/day). On days 19 and 26 after the start of dosing, they were challenged by pharyngeal aspiration of 250 µg OVA in the phosphate-buffered saline vehicle and sacrificed 24 hours after the last challenge. There was a dose-related decrease in number of splenocytes carrying the B220⁺ marker (expressed on B-cells, activated B-cells, and subsets of T- and natural killer- [NK-] cells) compared to the OVA controls. The changes were significantly different for the 25-mg/kg/day (p<0.05) and 37.5-mg/kg/day (p<0.01) groups.

After the day 19 challenge, the mice (n = 5) were placed in a plethysmography chamber for measurement of enhanced pause airway respiration (PenH) values. PenH values reflect volume of air in the lungs. Once in the chamber, they were challenged with nebulized methacholine for 3 mins followed by 2 mins of fresh air. The PenH measures were recorded every 30 seconds over the next 5 hours. The area under the plasma concentration time curve (AUC) for the PenH measures was determined after correction for baseline (acetone control, no OVA or PFOA). An AUC of 1.6 was considered to be a positive response. Twenty-four hours later, blood was drawn from the abdominal artery and the mice were sacrificed. The lungs were recovered for histological analysis. An increase in antigen-specific hyperactivity response to PFOA, in both the PenH values and the number of animals responding, was observed at doses up to about 25 mg/kg/day. The PenH AUC was significantly (p<0.05) increased in mice treated with 25 mg/kg/day PFOA and OVA compared to the OVA control mice, but there was no significant difference between the OVA control and the animals exposed to 50 mg/kg/day PFOA and OVA. The LOAEL for the PenH response was 25 mg/kg/day, and the NOAEL was 18.75 mg/kg/day.

Histopathological evaluation of the lungs revealed macrophage and eosinophil infiltration in response to the challenge with 250 µg OVA by pharyngeal aspiration. The severity of the response increased with increasing concentrations of PFOA. Eosinophils and macrophages were found in the interstitial, peribronchiole, and perivascular areas. Neutrophils, lymphocytes, and some multinucleated giant cells also were observed. Increased secretory matter, sloughing of epithelium, and secretory cell necrosis were observed in mice exposed to all concentrations of PFOA and OVA. The response was not observed in the mice exposed to only PFOA. The authors concluded that dermal exposure to PFOA was immunotoxic and enhanced the airway hypersensitivity response to OVA suggesting that PFOA may augment the IgE response to environmental allergens.

In vitro. In a pilot study, Brieger et al. (2011) examined the effects of PFOA on human leukocytes. Peripheral blood mononuclear cells (PBMCs) were obtained from the blood of 11 voluntary donors (n = 6 females, 5 males). PBMCs were incubated with varying concentrations of PFOA followed by assays for cell viability, proliferation, and NK cell activity. The human promyelocytic leukemia cell line, HL-60, was used in cell viability and monocyte differentiation assays. The various components of the assays employed are identified as follows:

- In the cell viability assay, the PBMCs were incubated with 0–500 µg/mL for 24, 48, and 72 hours, and HL-60 cells were incubated with 0–125 µg/mL PFOA for 24 hours.
- In the proliferation assay, the PBMCs were incubated with 0–100 µg/mL PFOA for 24 hours, labeled with 6-carboxyfluorescein succinimidyl ester (CFSE), stimulated with

ConA, a T-cell mitogen (5 µg/mL to half of all samples), and incubated for an additional 72 hours.

- For the NK assays, PBMCs were incubated with 0–100 µg/mL PFOA for 24 hours followed in incubation of 3 hours with K562 target cells (12.5:1 ratio) labeled with CFSE.
- In the monocyte differentiation assay, HL-60 cells were incubated with 0–100 µg/mL PFOA for 72 hours. Half of each sample was stimulated with 25 nmol calcitrol, 1 α ,25-dehydroxyvitamin D₃ (1,25D₃) 24 hours into the incubation period. Expression of CD11b and CD14 were measured as markers of differentiation.
- Whole blood was incubated with 0–100 µg/mL PFOA in the presence or absence of 25 µg/mL phytohemagglutinin (PHA), T-cell cytokine secretion stimulator for 48 hours in quantification assays for the cytokines TNF- α and IL-6. LPS (0 or 250 ng/mL) was added to whole blood incubated with 0.1–100 µg/mL PFOA either 4 or 24 hours prior to the end of the 48-hour incubation period to determine TNF- α and IL-6 release.

The plasma concentrations of PFOA were 3.3, 1.56, and 4.19 ng/mL for all, female, and male volunteers, respectively. Exposure to 31.3 and 62.5 µg/mL PFOA significantly increased PBMC viability at the 72-hour endpoint, and 62.5 µg/mL PFOA significantly increased cell viability at 24 hours. Exposure to 250 and 500 µg/mL PFOA significantly decreased cell viability at all time endpoints. Exposure to PFOA did not affect HL-60 cell viability. A trend towards slightly augmented proliferation was observed following incubation with PFOA. Of the nine samples used, cells from six donors had slightly increased proliferation and t had no response. In cells incubated with ConA and 100 µg/mL PFOA, a nonsignificant decrease in the number of proliferating cells was observed. PFOA decreased NK cell activity approximately 16% (not statistically significant). In the presence of 1,25D₃, 100 µg/mL PFOA significantly increased the percentage of HL-60 cells expressing CD11b and CD14. There were no differences in monocyte differentiation in the absence of 1,25D₃.

In whole blood, exposure to PFOA for 48 hours caused a slight increase in TNF- α and IL-6 levels. In the presence of PHA, a slight dose-dependent decrease in TNF- α and IL-6 was observed. There was a slight dose-dependent decrease in TNF- α release when LPS was added 4 hours before the end of the incubation period and a slight dose-dependent increase in IL-6 release when LPS was added 24 hours prior to the end of incubation. The authors also looked at the correlation between basal PFOA concentration and cytokine release. A significant association was observed between PFOA concentration and the release of LPS-induced TNF- α and IL-6 by peripheral monocytes. The authors suggested that the trends observed at the lower concentrations might show an impact on human immunity with a larger population.

Ahuja et al. (2009) examined the effects of PFOA on the production and activation of human monocyte-derived dendritic cells. These cells are responsible for a primary immune system response by activating lymphocytes and secreting cytokines. Peripheral monocytes and immature dendritic cells were incubated with 200 µmol PFOA from day 0 to day 6 or 8 to determine the impact on phenotype and cytokine secretion. Maturation stimulus (i.e., prostaglandin E₂, tumor necrosis factor, interleukin 1 β , and IL-6) was added during the last 48 hours of incubation to induce dendritic cell maturation. Mixed leukocyte reaction assays were conducted to determine if immature dendritic cells could stimulate T-cells. Cytokine (HLA-DR, CD25, CD80, CD83, and CD86) expression was measured as a determination of maturity. HLA-DR is a cytokine that presents antigens to elicit T-cell response. CD25, 80, 83, and 86 are cell receptors that act as co-receptors in T-cell activation; and interleukin 12p40 and 10 stimulate T-cells. Mature cytokine-

activated dendritic cells secrete interleukin 12p40 and interleukin 10 as antiinflammatory cytokines.

In peripheral monocytes incubated with only PFOA from day 0–6 or day 0–8, expression of HLA-DR and CD86 was increased compared to expression in control cells, indicating that immature dendritic cells were present. In the mixed leukocyte reaction assay, the ability to stimulate T-cells was not different between immature dendritic cells generated in the absence or presence of PFOA.

To determine if PFOA impacted the differentiation of immature dendritic cells to mature dendritic cells, immature dendritic cells were incubated with 200 μmol of PFOA for 6 days and the maturation stimulus was added for the final 2 days of incubation. There were no differences in cytokine (CD25, CD80, CD83, and CD86) expression between cells incubated with PFOA and control cells. Expression of interleukin 12p40 and interleukin 10 was significantly inhibited by PFOA in mature cytokine-activated dendritic cells, even in the presence of maturation stimulus during the last 48 hours of incubation. The result suggested that exposure to PFOA during generation of dendritic cells affected the phenotype and cytokine production of human dendritic cells and could lead to immunomodulation in the development of the immune response.

3.3.3 Hormone Disruption

Thyroid. Martin et al. (2007) administered 20 mg PFOA/kg to adult male Sprague-Dawley rats ($n = 4$ or 5) for 1, 3, or 5 days by oral gavage and determined the impact of PFOA on hormone levels. Blood was collected via cardiac puncture and the serum was analyzed for cholesterol, testosterone, FT4 and total T4, and total T3. RNA extracted from the livers was used for gene expression profiling, genomic signatures, and pathway analyses to determine a mechanism of toxicity.

Following a 1-day, 3-day, and 5-day dose, a significant decrease ($p < 0.05$) was observed in serum cholesterol ($\sim \downarrow 45\text{-}72\%$), total T4 ($\sim \downarrow 83\%$), FT4 ($\sim \downarrow 80\%$), and total T3 ($\sim \downarrow 25\text{-}48\%$). Serum testosterone was significantly decreased ($p < 0.05$, $\sim \downarrow 70\%$) following a 3-day and 5-day PFOA dose. PFOA treatment was matched to hepatotoxicity-related genomic signatures, as well as signatures for hepatocellular hypertrophy, hypocholesterolemia, hypolipidemia, and peroxisome proliferation. PPAR α nuclear regulated genes were induced by PFOA treatment. Genes associated with the thyroid hormone release and synthesis pathway including *Dio3*, which catalyzes the inactivation of T3, and *Dio1*, which deiodinates prohormone T4 to bioactivate T3, were affected by PFOA. Treatment with PFOA resulted in significantly upregulated expression of *Dio3* and downregulated expression of *Dio1* ($p < 0.05$). Expression of HMG-CoA reductase (involved in cholesterol biosynthesis) was significantly upregulated and cholesterol biosynthesis was downregulated in a manner consistent with PPAR γ agonists. The authors suggested a link between PFOA, PPAR, and thyroid hormone homeostasis based on work by Miller et al. (2001), who observed decreased serum T4 and T3 levels and increased hepatic proliferation following exposure to peroxisome proliferators. They also noted that PFOA exhibited similarities to compounds that induce xenobiotic metabolizing enzymes through PPAR γ and CAR. The 20-mg/kg/day dose was a LOAEL for the effects monitored after a 5-day exposure.

Reproductive Hormones. Cook et al. (1992) gavaged-dosed male CD rats ($n = 15$ per group) for 14 days with 0, 1, 10, 25, and 50 mg PFOA/kg/day to examine the possibility that an endocrine-related mechanism might explain Leydig cell adenomas observed in rats. A separate control group was pair-fed to the 50-mg/kg/day group. Blood and testicular interstitial fluid were

collected at necropsy for hormone analysis including testosterone, estradiol, and LH. A separate group of rats was dosed with 0 and 50 mg PFOA/kg/day for 14 days and challenged with 100 IUs of human chorionic gonadotropin (hCG) or 2 mg naloxone/kg 1 hour prior to necropsy to induce testosterone concentrations. Blood was collected and analyzed for testosterone and LH. Serum from rats challenged with 100 IUs hCG also was analyzed for P, 17 α -hydroxyprogesterone, and androstenedione.

The relative liver weight at 10, 25, and 50 mg PFOA/kg/day was significantly increased ($p < 0.05$). The accessory sex organ unit relative weight was significantly decreased ($p < 0.05$) at 25 and 50 mg PFOA/kg/day compared to those weights in control rats. The relative weights of the liver, accessory sex organ unit, and ventral prostate were significantly decreased at the highest dose compared to the pair-fed control.

Serum estradiol was significantly increased at ≥ 10 mg PFOA/kg compared to the control. No differences were observed in testosterone and LH between the treated rats and control. In the challenge experiment, serum testosterone was significantly decreased ($p < 0.05$) by treatment with 50 mg PFOA/kg after challenge with 100 IUs hCG. No differences in testosterone concentration were observed in the naloxone-challenged rats, and no differences in LH were observed after either challenge. In the hCG-challenged rats, androstenedione was significantly reduced at 50 mg PFOA/kg, but no differences in concentrations were observed in P or 17 α -hydroxyprogesterone between control and treated rats. The authors suggested that the observed decreased serum testosterone levels could be due to decreased conversion of 17 α -hydroxyprogesterone to androstenedione as a result of increased serum estradiol levels. The LOAEL was 10 mg/kg based on increased liver weight and increased serum estradiol levels, and the NOAEL was 1 mg/kg.

Biegel et al. (1995) conducted *in vitro*, *in vivo*, and *ex vivo* studies to determine the effects of PFOA on Leydig cell function. In the *in vitro* study, Leydig cells were cultured with ± 2 IUs hCG (for final 3 hours) and 0, 100, 200, 250, 500, 700, and 1000 μmol PFOA for a total of 5 hours and then analyzed for testosterone concentration. Leydig cells also were incubated ± 500 μmol PFOA and analyzed for testosterone and estradiol at 0, 0.5, 1, 3, 6, 12, 24, and 48 hours.

In the *in vitro* studies, there was no effect of PFOA treatment on testosterone in Leydig cells cultured without hCG. In cells cultured with hCG, PFOA caused a dose-dependent decrease in testosterone production. At 100 μmol PFOA plus hCG, the testosterone concentration was significantly increased compared to cells treated with only 100 μmol PFOA. Cytotoxicity occurred at ≥ 750 μmol PFOA. In the time course experiment, 500 μmol PFOA significantly inhibited hCG-stimulated release of testosterone at time points of at least 3 hours compared to control. Estradiol levels of PFOA-treated Leydig cells at 48 hours were statistically greater than the control.

Male CD rats were gavage-dosed for 14 days with 0, 0 pair-fed, or 25 mg PFOA/kg and necropsied on day 15. Blood and testicular interstitial fluid were collected for hormone analysis. Liver samples were collected for analysis of peroxisomal β -oxidation and microsomal aromatase activities. Serum estradiol was significantly increased ($p < 0.05$) by 25 mg PFOA/kg when compared to the *ad libitum* and pair-fed control rats. Testicular interstitial fluid testosterone concentration was significantly decreased ($p < 0.05$) and microsomal aromatase activity, and peroxisomal β -oxidation activity were significantly increased ($p < 0.05$) in PFOA-treated rats compared to the pair-fed control rats.

Leydig cells from the treated rats in the *in vivo* study were isolated and cultured for analysis of testosterone concentration for the *ex vivo* study. An increase of 8.6-fold in testosterone production ($p < 0.05$) was observed in Leydig cells isolated from PFOA-treated rats. The authors suggested that the increased serum estradiol levels resulted from liver aromatase induction by PFOA, and that PFOA could directly affect Leydig cell function.

Liu et al. (1996) treated adult male Crl:CD(BR) rats ($n = 15$ per group) with 0, 0 pair-fed, 0.2, 2, 20, and 40 mg PFOA/kg for 14 days by oral gavage to determine the impact of PFOA on aromatase activity. At necropsy on day 15, blood was collected for serum estradiol determination. Liver samples were collected for determination of microsomal aromatase activity and total P450 concentration. The testes were collected and testicular aromatase was determined.

The body weight of rats treated with ≥ 20 mg PFOA/kg was significantly decreased ($p < 0.05$) compared to the control rats. Pair-fed control rats also had significantly decreased body weight compared to the control rats. Body weight was not different between the pair-fed control rats and rats dosed with 40 mg/kg PFOA. Absolute and relative liver weights were significantly increased ($p < 0.05$) at ≥ 2 mg PFOA/kg. Relative testes weight was significantly increased at ≥ 20 mg PFOA/kg, but the differences were due to decreased body weight. There were no differences observed in testicular aromatase activity. In the remaining analysis, the pair-fed control group was similar to the *ad libitum* control group. The protein yield of hepatic microsomes was significantly increased at ≥ 0.2 mg PFOA/kg, and hepatic aromatase activity, total hepatic aromatase activity adjusted for liver and body weight effects, and serum estradiol were significantly increased ($p < 0.05$) at ≥ 2 mg PFOA/kg. The maximum increase in total hepatic aromatase activity was 16-fold and the increase was twofold for serum estradiol. A significant correlation ($p < 0.0001$) was observed between total hepatic aromatase activity and serum estradiol. The aromatase activity in liver microsomes isolated from control rats and incubated for 2 hours with PFOA was significantly decreased at ≥ 100 μmol . The authors estimated the half maximal effective concentration (EC_{50}) values for the outcomes, and they are shown in Table 3-36. Liu et al. (1996) concluded that the PFOA-increased protein yields suggested induction of the ER resulting in aromatase induction, which led to increased serum estradiol. However, PFOA also inhibited aromatase activity, which would explain why serum estradiol was only increased up to twofold.

Table 3-36. Estimated EC_{50} Values

Parameters	EC_{50} (mg PFOA/kg)
Hepatic microsome protein yield	0.53
Hepatic microsomal aromatase activity	0.76
Absolute liver weight	1.07
Relative liver weight	1.56
Serum estradiol	3.24
Terminal body weight	11.65

Source: Liu et al. 1996

Note: EC_{50} = half-maximum response.

A separate component of the Liu et al. study (1996) examined the effect of PFOA on aromatase activity in cultured hepatocytes and is discussed below. Aromatase is a cytochrome P450 enzyme localized to the ER that catalyzes the conversion of androgens to estrogens. The cultured hepatocytes isolated from control male CD rats were incubated with 0–1000 μmol PFOA and the aromatase activity was evaluated after 18, 42, and 66 hours (Liu et al. 1996).

Compared to aromatase activity in time-matched control cultures, PFOA caused a decrease in aromatase activity after 18 and 42 hours incubation with hepatocytes and an increase after the 66-hour incubation period.

In their study examining the impact of PFOA on aromatase activity, Liu et al. (1996) also examined the impact of PFOA on peroxisome β -oxidation and cytochrome P450 activities. Male Crl:CD BR (CD) rats (n = 15 per group) were orally dosed with 0, 0 pair-fed, 0.2, 2, 20, and 40 mg PFOA/kg for 14 days. Liver samples were collected for determination of microsomal total cytochrome P450 concentration and peroxisome β -oxidation activity. Total cytochrome P450 was significantly increased (p<0.05) at ≥ 20 mg PFOA/kg and β -oxidation activity was increased at ≥ 2 mg PFOA/kg. The estimated EC₅₀s for total cytochrome P450 and β -oxidation were 18.18 and 2.19 mg PFOA/kg, respectively. The LOAEL was 2 mg/kg based on increased liver weight, serum estradiol, and hepatic aromatase activity, and the NOAEL was 0.2 mg/kg.

Hines et al. (2009) examined the roles that exposure to PFOA and ovarian hormones might play in animals exposed during gestation compared to during their adult years. Timed-pregnant CD-1 mice were gavaged-dosed in two blocks on GDs 1–17, but not thereafter. Block 1 animals were dosed with 0, 1, 3, and 5 mg PFOA/kg, and block 2 animals were dosed with 0, 0.01, 0.1, 0.3, 1, and 5 mg PFOA/kg/day. At birth, pups were pooled within each block and dose group and randomly redistributed among the dams (10 pups per litter). Offspring were weaned at 3 weeks, and a subset of females from each dose group (0, 0.01, 0.1, 0.3, 1, and 5 mg PFOA/kg/day) was OVX at weaning or the day after weaning. All animals were observed until they reached 18 months of age.

Body weight was recorded weekly for the first 9 months of age, followed by monthly body weight recordings over the next 9 months. As the animals matured, they were evaluated for the endpoints listed in Table 3-37. A group of naive 8-week-old adult mice were dosed for 17 days with 0, 1, and 5 mg PFOA/kg/day to compare the impact of exposure in adult animals to those occurring during gestation. At 18 months of age, the mice were sacrificed. Blood, retroperitoneal abdominal fat, interscapular brown fat, organs, and abnormal growths were collected at necropsy.

Table 3-37. Data Collection for Female Mice Gestationally Exposed to PFOA

Test	Age at Test	Dose (mg/kg/day)	Group
Glucose tolerance test	15-16 weeks	0, 1, 5	Intact
Serum leptin and insulin	21-33 weeks	0, 0.01, 0.1, 0.3, 1	Intact, OVX
Body mass composition	42 weeks	0, 0.01, 0.1, 0.3, 1	Intact
Glucose tolerance test	17 months	0, 0.1, 1, 5	Intact
Food consumption	17 months	0, 0.1, 1, 5	Intact
Serum estradiol	18 months	0, 0.01, 0.1, 0.3, 1, 5	Intact

Source: Hines et al. 2009

Body weight of offspring born to dams exposed to 5 mg PFOA/kg was significantly decreased (p<0.05) on PND 1 and through 18 months of age compared to control offspring body weight. At weaning, the body weight of offspring born to dams exposed to 1 mg PFOA/kg/day was significantly decreased (p<0.05) compared to control offspring body weight. A significant increase (p<0.05) in body weight, due to more rapid weight gain after week 10, compared to intact control body weight, was observed in intact mice exposed to 0.01–0.3 mg PFOA/kg/day

during gestation. Body weight of intact mice gestationally exposed to 0.01–0.3 mg PFOA/kg/day was comparable to body weight of control mice at 18 months.

Due to the increased weight gain observed in intact mice exposed to PFOA during gestation, glucose tolerance tests were carried out along with determination of serum insulin concentration. In cases of insulin resistance, plasma glucose and insulin levels are elevated and the insulin response is lessened. Insulin resistance also has been associated with excess abdominal fat. Serum leptin levels also were determined as increased leptin levels have been associated with a leptin-resistance mechanism of action (MOA) for increased weight gain in humans. Body mass composition was used to determine if there were differences in body fat between the intact groups, and feed consumption was recorded to determine if consumption played a role in body weight differences in intact control and intact gestationally exposed mice. Serum estradiol was measured to determine if PFOA impacted hormone levels at 18 months in intact control and intact gestationally exposed mice.

Glucose tolerance testing showed no statistically significant differences in baseline glucose or response to glucose challenge at 15–16 weeks or at 17 months. At 21 and 31 weeks of age, a significant increase in serum leptin and insulin levels was observed in intact mice exposed to 0.01 and 0.1 mg PFOA/kg/day. No statistically significant difference was observed between the fat-to-lean ratio of intact control and intact gestationally exposed animals at 42 weeks of age. No significant difference was observed in food consumption between intact control and intact gestationally exposed animals at 42 weeks of age. Serum estradiol levels were not different between intact control and intact gestationally exposed animals at 18 months.

Exposure to PFOA as an adult did not result in body weight differences among the groups at 18 months of age. The body weight of intact mice gestationally exposed to 1 mg PFOA/kg/day was significantly increased ($p < 0.05$) compared to adult mice exposed to 1 mg PFOA/kg/day. No other differences in body weight among the groups were observed.

No significant differences among the groups were observed in survival during the 18-month study. At necropsy, abdominal white fat was significantly decreased ($p < 0.05$) at 1 and 5 mg PFOA/kg/day in gestationally exposed intact mice compared to intact control mice. Interscapular brown fat was significantly increased ($p < 0.05$) at 1 and 3 mg PFOA/kg/day in gestationally exposed intact mice and in gestationally exposed OVX mice at 1 mg PFOA/kg/day. Relative spleen weight was significantly decreased ($p < 0.05$) at 3 mg PFOA/kg/day in gestationally exposed intact mice and at 1 and 5 mg PFOA/mg ($p = 0.05-0.07$) in gestationally exposed OVX mice. Relative liver weight was not different between the groups. No differences were observed at 18 months of age in tissue weight in mice exposed to PFOA as adults. At 1 mg PFOA/kg/day, white and brown fat weight was significantly increased in gestationally exposed intact mice compared to adult-exposed mice exposed to 1 mg PFOA/kg/day.

The authors concluded that developmental exposure to low doses and high doses of PFOA resulted in different phenotypes in mice. At low doses, increased weight, increased serum insulin, and increased serum leptin were observed in adult mice. At high doses the animals displayed decreased weight in early and late life, decreased white fat, increased brown fat, and decreased spleen weight. Under the conditions of the study, the developmental LOAEL was 0.01 mg PFOA/kg based on increased weight gain and increased serum insulin and leptin levels. No developmental NOAEL was established. The adult NOAEL was 5 mg PFOA/kg, and no LOAEL was established.

Adrenal Hormones. Thottassery et al. (1992) exposed intact or ADX male Sprague-Dawley rats to a single dose of 150 mg/kg PFOA in corn oil to determine the role of adrenal hormones on liver enlargement and peroxisomal proliferation. ADX rats were dosed 2 days after surgery with PFOA (ADX PFOA), CORT (ADX CORT), or both (ADX CORT PFOA). A group of intact and ADX rats received only the vehicle and served as controls. The animals were sacrificed 48 hours after dosing with PFOA or vehicle. Assays were conducted to determine DNA levels and changes in peroxisomal β -oxidation, catalase, and ornithine decarboxylase activities. An increase in ornithine decarboxylase activity has been associated with proliferation of many different cell types. An increase of ornithine decarboxylase in the livers of animals exposed to PFOA would suggest that the increased liver weight observed in PFOA-exposed animals was the result of hyperplasia. Ornithine decarboxylase was determined by measuring liberated CO₂ from DL-[1-¹⁴C] ornithine hydrochloride in all animals except those in the ADX CORT PFOA group.

Relative liver weight in intact rats treated with PFOA was significantly increased compared to control (36%, $p < 0.05$). Relative liver weight in rats in the ADX PFOA group was significantly increased compared to rats in the ADX vehicle group (16%, $p < 0.05$). Relative liver weight in rats in the ADX CORT PFOA group was significantly increased compared to rats in the ADX CORT group (32%, $p < 0.05$). Hepatic DNA levels were significantly decreased ($p < 0.001$) in intact rats treated with PFOA and in rats in the ADX CORT PFOA group.

Ornithine decarboxylase activity was significantly increased in the rats in the ADX PFOA group compared to rats in the ADX group (170.5 pmole CO₂/hr/mg protein, versus 30.5 pmole CO₂/hr/mg protein, $p < 0.001$), but no different between the intact rats treated with PFOA and the intact rats treated with the vehicle.

PFOA increased whole liver peroxisomal β -oxidation activity by a similar amount and was not different among the groups. In intact rats and rats in the ADX CORT PFOA group, exposure to PFOA increased whole liver catalase activity, but exposure did not increase activity in the rats in the ADX PFOA group. Based on the results, the authors concluded that adrenal hormones were not required to induce peroxisomal β -oxidation activity in PFOA-exposed rats, but are required to increase catalase activity. They also concluded that the enlarged livers of PFOA-exposed animals were the result of hypertrophy rather than hyperplasia based on decreased hepatic DNA content and lack of increased ornithine decarboxylase activity.

3.3.4 Physiological or Mechanistic Studies

Gene Expression. Rosen et al. (2007) examined the gene expression profile in the lung and liver of mouse fetuses exposed to PFOA. Pregnant CD-1 mice were gavaged with 0, 1, 3, 5, and 10 mg PFOA/kg/day on GD 1–17. Dams were sacrificed on GD 18, and three fetuses per litter were processed for total RNA from portions of the liver and lung. Global gene expression was analyzed using Affymetrix gene chips.

A dose-related increase was observed in the number of genes altered by PFOA exposure in both the liver and lung. A greater number of genes in the liver were altered compared the number of genes altered in the lung. Analysis of the genes by canonical pathway or biological function showed that most of the altered genes in both the liver and lung were associated with lipid homeostasis. In the fetal lung, the two highest doses of PFOA altered genes associated with fatty acid catabolism. In the fetal liver, all doses of PFOA were associated with genes involved in fatty acid catabolism, lipid transport, cholesterol biosynthesis, bile acid biosynthesis, lipoprotein metabolism, steroid metabolism, retinol metabolism, inflammation, phospholipid metabolism,

glucose metabolism, proteasome activation, and ketogenesis. Although PPAR α is known to at least partly regulate the expression of genes for the pathways or biological functions involved in lipid homeostasis, PFOA might independently activate other nuclear receptors, influencing the metabolic responses observed.

Rosen et al. (2008a) described the gene profiles in liver tissue from wild-type 129S1/SvImJ mice (7–8 per group) and PPAR α -null mice (129S4/SvJae-PPAR α ^{mlGonz}/J, 6–8 per group) dosed for 7 days with 0, 1, and 3 mg PFOA/kg or 50 mg Wyeth 14,643, a PPAR α agonist (Wolf et al. 2008a). RNA was isolated from the tissues and gene expression analyzed using Applied Biosystems Mouse Genome Survey Microarrays. RT-PCR was used to evaluate selected genes.

In both wild-type and PPAR α -null mice exposed to PFOA, the number of significant and fully annotated genes used to evaluate the data for relevance to canonical pathway or biological function were fewer at 1 mg/kg than at 3 mg/kg PFOA. However, 85% of the altered genes at 1 mg/kg PFOA also were altered at 3 mg/kg PFOA.

PPAR α target genes including acyl-CoA oxidase 1 (Acox1), Me1, Slc27a1, Hsd17b4, Hadha, Hadhb, and Pdk4 were upregulated in PFOA- and Wyeth 14,643-treated wild-type mice, but not in PPAR α -null mice. Pdk4 was downregulated in PPAR α -null mice exposed to PFOA but not in PPAR α -null mice exposed to Wyeth 14,643. Principal components analysis showed that genes activated in PFOA-treated PPAR α -null mice were similar to those in PFOA-treated wild-type mice at 3 mg PFOA/kg, suggesting that many of the responses were not completely linked to PPAR α .

In wild-type PFOA- and Wyeth 14,643-treated mice, alterations were observed in genes associated with fatty acid metabolism (mostly upregulated), inflammatory response (mostly downregulated), cell cycle control (mostly upregulated), peroxisome biogenesis (mostly upregulated), and proteasome structure and organization (mostly upregulated). In genes associated with xenobiotic metabolism, the response was different between PFOA- and Wyeth 14,643-treated wild-type mice. Many of the Cyp2 genes were upregulated by PFOA and downregulated by Wyeth 14,643. In PPAR α -null PFOA-treated mice, genes associated with fatty acid metabolism, inflammation, xenobiotic metabolism, and cell cycle control were altered in a manner similar to the changes observed in PFOA-treated wild-type mice.

RT-PCR generally revealed good agreement with microarray analysis. However, expression of Ehhadh, a PPAR α -regulated gene, was upregulated in PFOA-treated wild-type mice but not in PFOA-treated PPAR α -null mice in microarray analysis. In contrast, expression of Ehhadh was upregulated in all PFOA-treated mice in RT-PCR analysis. The authors concluded that PFOA induces transcriptional changes mediated through PPAR α activation, and it also alters gene expression independently of PPAR α . They noted that PFOA had multiple modes of action and can function as a biologically active xenobiotic in the absence of PPAR α .

Rosen et al. (2008b) described the transcript profiles in the livers of adult mice exposed to PFOA. Tissues from several different studies were analyzed. The samples included liver tissue from:

- male wild-type (strain 129S1/SvImJ) and PPAR α -null (strain 129S4/SvJae) mice dosed with 3 mg/kg/day PFOA for 7 days (from Wolf et al. 2008a);
- male wild-type and PPAR α -null mice (strain SV129/C57BL/6) gavaged or fed diets containing Wyeth 14,643 (PPAR α agonist);

- female wild-type and CAR-null (strain C57BL/6x129Sv) gavaged with CAR activators phenobarbital (PB) or 1,4-bis[2-(3,5-dichloropyridyloxy)] benzene (TCPOBOP); and
- wild-type and Nrf-null ICR mice gavaged with the Nrf activator dithiol-3-thione.

RNA was isolated from the tissues and gene expression was analyzed using Affymetrix full genome mouse chips. Rosetta Resolver software was used to identify significantly altered genes.

Exposure to 3 mg/kg PFOA for 7 days upregulated 641 genes and downregulated 451 genes in wild-type mice compared to 104 upregulated genes and 52 downregulated genes in PPAR α -null mice. A total of 117 genes were regulated similarly in both strains, and 29 upregulated genes and 11 downregulated genes were unique to PPAR α -null mice.

The gene expression profile of wild-type and PPAR α -null mice exposed to PFOA for 7 days or Wyeth 14,643 for 12 hours, or 3 or 7 days were compared. Four groups of altered genes were identified based on their expression in wild-type and PPAR α -null PFOA-exposed mice compared to genes from Wyeth 14,643-treated mice. The first group consisted of genes (397) regulated by both PFOA and Wyeth 14,643 in wild-type mice. They had a common direction and magnitude of change and were characterized as being involved in lipid homeostasis, inflammation, cell proliferation, or proteome maintenance genes. Group II consisted of genes in wild-type mice (51) regulated solely by PFOA; most were involved in amino acid metabolism. Of the 81 genes altered by PFOA exposure in PPAR α -null mice (Group III), 62 had similar expression in wild-type mice and many were involved in lipid metabolism. Regulation of these genes also was observed in Wyeth 14,643 wild-type mice. Group IV genes (19) were altered by PFOA only in PPAR α -null mice; most were xenobiotic metabolizing enzymes.

By comparing the gene expression patterns between PFOA and Wyeth 14,643, the authors concluded that:

- PPAR α is required for a majority of the transcriptional changes observed in the mouse liver following PF also are regulated by other peroxisome proliferators in a PPAR α -dependent manner; and
- PFOA impacts some PPAR α -independent genes including ones involved in lipid homeostasis (upregulated), amino acid metabolism (downregulated), and xenobiotic metabolism (upregulated).

The transcription profiles of PFOA exposed wild-type and PPAR α -null mice were compared to the transcription profile of PB- or TCPOBOP-exposed wild-type and CAR-null mice and dithiol-3-thione-exposed wild-type and Nrf2-null mice to determine if PFOA activated CAR or Nrf2. A similar pattern was observed in the modified gene expression of PFOA-exposed PPAR α -null mice and PB- (0.86 Pearson's correlation) or TCPOBOP- (0.84 Pearson's correlation) exposed wild-type mice, but no pattern was observed in gene expression of dithiol-3-thione-exposed mice (≤ 0.06 Pearson's correlation) and PFOA-exposed PPAR α -null mice. These results suggest that some genes altered by PFOA exposure in PPAR α -null mice are regulated by CAR but not by Nrf2.

Bjork and Wallace (2009) examined the PPAR α -dependent transcriptional activation potential of PFOA in rodent and human hepatic liver cells. Primary rat and human hepatocytes and HEPG2/C3A cells were incubated with 0, 5, 10, 20, 30, 50, 100, and 200 μ mol PFOA for 24 hours. Expression of Acox, Cyp4a1 (rat), Cyp4a11 (human), acyl-CoA thioesterase (Cte-rat, Acot1-human), and DNA damage inducible transcript (Ddit3) were determined by quantitative

RT-PCR. These genes are inducible by peroxisome proliferators, except *Ddit3*, which is induced in the presence of direct or indirect DNA damage. Exposure to ≥ 100 μmol PFOA significantly increased *Ddit3* mRNA expression in primary rat hepatocytes. At the highest dose, *Ddit3* was significantly increased in human hepatocytes and HepG2/C3A cells. Expression of *Acox* was significantly induced by 5, 10, 20, and 30 μmol PFOA, and *Cte/Acot1* was significantly induced at ≥ 20 μmol PFOA in rat hepatocytes only. Expression of *Cyp4a1/11* was significantly induced in rat hepatocytes at 5–50 μmol and in human hepatocytes at 20–50 μmol . The authors concluded that induction of peroxisome-related fatty acid oxidation gene expression is not observed in primary human liver cells or in transformed human liver cells *in vitro*.

Nakamura et al. (2009) investigated the differences in PFOA response between mice and humans using a humanized PPAR α transgenic mouse line (hPPAR α). The study design and whole animal toxicity data are described in section 3.2.2. Male 8-week-old wild-type (mPPAR α) mice, PPAR α -null mice, and hPPAR α mice were gavage-dosed with 0, 0.1, and 0.3 mg/kg PFOA (n = 4–6 per group) for 2 weeks and sacrificed 18–20 hours following the last dose. Livers were collected and analyzed for mRNA (RT-QPCR) and protein levels (western blot analysis) of PPAR α and related genes (retinoid X receptor alpha [RXR α], peroxisomal bifunctional protein [PH], peroxisomal thiolase [PT], very long chain acyl-CoA dehydrogenase [VLCAD], medium chain acyl-CoA dehydrogenase [MCAD], and cytochrome P450 4a10 [CYP4A10]). RXR α forms a heterodimer with PPAR α to control transcription of genes affecting lipid metabolism. CYP4A10 also plays a role in lipid metabolism. Treatment with peroxisome proliferators caused an increase in both PH and PT. MCAD and VLCAD are mitochondrial fatty acid metabolizing enzymes whose gene expression is mediated by PPAR α (Aoyama et al. 1998). The results of mRNA expression impacted by PFOA exposure are shown in Table 3-38.

Treatment with PFOA did not alter mRNA expression or protein expression of PPAR α , RXR α , or MCAD in mPPAR α mice. At 0.1 mg/kg PFOA, mRNA expression of CYP4A10 was significantly increased (p<0.05) in mPPAR α mice compared to control mPPAR α mice. Treatment with 0.3 mg/kg PFOA resulted in significantly increased (p<0.05) mRNA expression of CYP4A10 and mRNA and protein expression of PH, PT, and VLCAD in mPPAR α mice when compared to control mPPAR α mice.

Table 3-38. mRNA Expression of Hepatic PPAR α and Related Genes

	mPPAR α			PPAR α -null			hPPAR α		
	0 mg/kg	0.1 mg/kg	0.3 mg/kg	0 mg/kg	0.1 mg/kg	0.3 mg/kg	0 mg/kg	0.1 mg/kg	0.3 mg/kg
PPAR α	-	-	-	NA	NA	NA	-* \uparrow	-* \uparrow	-* \uparrow
RXR α	-	-	-	-	-	-	-	-	-
PH	-	-	+ \uparrow	-	-* \downarrow	-* \downarrow	-	-* \downarrow	-* \downarrow
PT	-	-	+ \uparrow	-	-* \downarrow	-* \downarrow	-* \uparrow	-	-
VLCAD	-	-	+ \uparrow	-* \downarrow	-* \downarrow	-* \downarrow	-	-* \downarrow	-* \downarrow
MCAD	-	-	-	-	-* \downarrow	-	-	-* \downarrow	+ \uparrow
CYP4A10	-	+ \uparrow	+ \uparrow	-	-* \downarrow	-* \downarrow	-* \uparrow	-* \downarrow	-* \downarrow

Source: Nakamura et al. 2009

Notes:

- Not different from respective control.

+ Significantly different from respective control.

* Significantly different from mPPAR α mice treated with same concentration.

\downarrow Decreased expression relative to respective control or mPPAR α mice at same concentration.

\uparrow Increased expression relative to respective control or mPPAR α mice at same concentration.

As expected, mRNA and protein expression of PPAR α was absent in PPAR α -null mice. Treatment with 0.1 and 0.3 mg/kg PFOA did not alter mRNA or protein expression for any genes investigated compared to control PPAR α -null mice. VLCAD mRNA expression and PT protein expression in control PPAR α -null mice was significantly decreased ($p < 0.05$) compared to mPPAR α control mice. VLCAD mRNA and protein expression of PFOA treated PPAR α -null mice was significantly decreased ($p < 0.05$) compared to mPPAR α mice treated with the same doses. Following treatment with 0.1 mg/kg PFOA, MCAD mRNA expression was decreased ($p < 0.05$) compared to mPPAR α mice treated with the same dose. When compared to mPPAR α mice treated with the same dose, mRNA and protein expression of PH and PT was significantly decreased ($p < 0.05$) in PPAR α -null mice, as was CYP4A10 mRNA expression.

Treatment with PFOA did not alter mRNA or protein expression of PPAR α , RXR α , PH, PT, or VLCAD in hPPAR α mice compared with their respective controls. Expression of CYP4A10 mRNA also was not altered by PFOA treatment. MCAD mRNA and protein expression were significantly increased ($p < 0.5$) in hPPAR α mice treated with 0.3 mg/kg PFOA compared to hPPAR α control mice. Expression of PPAR α mRNA and protein levels were significantly higher ($p < 0.05$) in all hPPAR α mice than in mPPAR α mice given the same concentration of PFOA. Treatment of hPPAR α mice with 0.1 and 0.3 mg/kg PFOA caused a decrease ($p < 0.05$) in mRNA expression of PH, VLCAD, and CYP4A10 compared to mPPAR α mice at the same dose. Only hPPAR α mice treated with 0.3 mg/kg PFOA had decreased protein expression of PH and VLCAD compared to mPPAR α mice given the same treatment. An important finding from this study was the significant downregulation of some genes in PPAR α -null and hPPAR α mice that are significantly upregulated by PPAR α in the control animals. In the animals with the humanized PPAR α gene or no PPAR α gene, there was a response, but the response was the opposite of what occurred with normal mouse PPAR α activation. In the null and humanized mice, the significantly decreased alterations in gene expression occurred at 0.1 mg/kg/day; this dose level had no change in expression for all but one gene in the normal mice and increased expression, rather than decreased expression, at 0.3 mg/kg/day (see Table 3-38).

Treatment with 0.3 mg/kg PFOA caused activation of PPAR α in mouse, but not in humanized PPAR α mice. The results suggest that the functional activation of human PPAR α could be weaker than that of mice as expression of human PPAR α in mice was greater than the expression of mouse PPAR α . Higher concentrations of PFOA might be needed to cause activation of human PPAR α in hPPAR α mice.

To further evaluate the developmental effects potentially mediated by PPAR α , groups of female wild-type, PPAR α -null, and PPAR α -humanized mice were given 0 and 3 mg PFOA/kg on GDs 1–17 by oral gavage (Albrecht et al. 2013). The study design and developmental toxicity data are described in section 3.2.5. Females were either sacrificed on GD 18 ($n = 5–8$ per group) or allowed to give birth and then sacrificed, along with their litters ($n = 8–14$), on PND 20. Livers from dams, fetuses, and pups were collected for measurement of mRNAs encoding the PPAR α target genes Cyp4a10 and Acox1, the CAR target gene (Cyp2b10), and the PXR target gene (Cyp3a11).

On GD 18, maternal liver samples from treated groups showed increased expression of Acox1 in wild-type mice and Cyp4a10 in wild-type and humanized mice. Expression of Cyp2b10 and Cyp3a11 were increased following PFOA administration in all three genotypes. On PND 20, maternal liver samples from treated groups showed increased expression of Acox1 in wild-type mice; expression of Cyp2b10 was unchanged in all groups; and expression of Cyp3a11 was increased following PFOA administration in all three genotypes.

For fetuses on GD 18, liver samples from treated groups showed increased expression of Acox1 and Cyp4a10 in wild-type and humanized mice. Expression of Cyp2b10 was unchanged following maternal PFOA administration in all three genotypes, while expression of Cyp3a11 was increased in humanized fetal liver. On PND 20, pup liver samples from treated dams showed increased expression of Acox1 and Cyp4a10 in wild-type mice; expression of Cyp2b10 was increased in all genotypes; and expression of Cyp3a11 was increased following maternal PFOA administration in wild-type and humanized pups. Thus, expression of PPAR α target genes that modulate lipid metabolism was increased in both wild-type and humanized mice coincident with increased liver weight and microscopic lesions; however, the neonatal mortality was observed only in wild-type offspring (Albrecht et al. 2013).

Walters et al. (2009) examined the impact of PFOA on mitochondrial biogenesis and gene transcription in adult male Sprague-Dawley rats orally dosed with 0 or 30 mg/kg PFOA for 28 days. At sacrifice, a portion of the midlobe region of the livers was collected. Liver DNA and RNA were isolated for RT-PCR of genes in the peroxisome proliferator-activated receptor gamma coactivator 1 α - (Pgc-1 α -) mediated pathway of mitochondrial biogenesis: Pgc-1 α , estrogen-related receptor α (Err α), nuclear respiratory factor 1 (Nrf1) and Nrf2, transcription factor A (Tfam), cytochrome c oxidase subunit II and IV (Cox II and Cox IV), NADH dehydrogenase 2 (Nd2), and NADH dehydrogenase iron-sulfur protein 8 (Ndufs8). In mitochondrial biogenesis, Pgc-1 α and Err α increase expression of the transcription factors Nrf1 and Nrf2. The Nrf transcription factors promote expression of Tfam, which is required for mitochondrial DNA replication and transcription. Within the mitochondrial membrane, oxidative phosphorylation proteins (Cox II and IV, Nds, and Ndufs8) catalyze the transfer of electrons and/or pump protons from the matrix to the intermembrane space. Western blotting was used to analyze protein expression of Pgc-1 α , Tfam, Cox II, and Cox IV.

Mitochondrial DNA in rats treated with PFOA was significantly increased ($p < 0.05$) compared to control rats. In PFOA-treated rats, the expression of Pgc-1 α , Err α , Nrf1, Nrf2, and Tfam was significantly increased 1.3–2.2-fold ($p < 0.05$), and expression of Cox II, Cox IV, Nd2, and Ndufs8 was significantly increased 2–9-fold ($p < 0.05$) compared to controls. Protein expression of Pgc-1 α was increased, and expression of Cox II and Cox IV were decreased in PFOA-treated rats. Protein expression of Tfam was not affected by treatment with PFOA. The results suggested that PFOA induced mitochondrial biogenesis at the transcriptional level by activation of the Pgc-1 α pathway, confirming the potential for effects on mitochondria but not clarifying whether those effects are in some way linked to PPAR α activation.

Elcombe et al. (2010) examined the expression of some cytochrome P450 isoforms in the livers of male Sprague-Dawley rats fed diets containing 300 ppm PFOA or 50 ppm Wyeth 14,643 for 1, 7, or 28 days. The isoforms included those involved in activation of PPAR α (CYP4A1), CAR (CYP2B1/2), and PXR (CYP3A1). All three isoforms were induced by PFOA exposure. CYP2B1/2 and CYP4A1 were induced after 1 day of exposure to PFOA. CYP3A1 was induced in all PFOA-exposed rats after 7 days of exposure. Treatment with Wyeth 14,643 caused the induction of CYP4A1 only.

PPAR Activation. Takacs and Abbott (2007) evaluated the potential for PFOA to activate PPARs, using a transient transfection cell assay. Cos-1 cells, derived from the kidney cells of the African green monkey, were transfected with mouse or human PPAR α , PPAR β/δ , or PPAR γ reporter plasmids and exposed to 0.5–100 μmol PFOA or 0.5–100 μmol PFOA and MK-886 (PPAR α antagonist) or GW9662 (PPAR γ antagonist). An antagonist for PPAR β/δ was not available. The three types, PPAR α , β/δ , and γ , are encoded by different genes, expressed in many

tissues, and have specific roles during development as well as in the adult. The results are shown in Table 3-39. PFOA activated PPAR α in a dose-dependent manner with a significant increase in activity observed at 10, 20, 30, and 40 μ mol for the mouse receptor and 30 and 40 μ mol for the human receptor compared to the negative control. The presence of the PPAR α antagonist MK-886 prevented the activity increase resulting from PFOA exposure alone in mouse and human PPAR α constructs.

Table 3-39. Activation of Mouse and Human PPAR by PFOA

PPAR α			PPAR β/δ			PPAR γ		
PFOA (μ m)	Mouse	Human	PFOA (μ m)	Mouse	Human	PFOA (μ m)	Mouse	Human
0	-	-	0	-	-	0	-	-
0.5	-	-	10	-	-	1	-	-
1	-	-	15	-	-	5	-	-
3	-	-	20	-	-	10	-	-
5	-	-	30	-	-	20	-	-
10	+	-	40	+	-	30	-	-
15	-	-	50	+	-	40	-	-
20	+	-	60	+	-	50	-	-
30	+	+	70	+	-	75	-	-
40	+	+	80	+	-	100	-	-

Source: Takacs and Abbott 2007

Notes:

+ Significant increase in activity between treated and control.

- No difference in activity between treated and control.

Activity of mouse PPAR β/δ was significantly increased after exposure to 40–80 μ mol PFOA compared to the negative control. Activity of human PPAR β/δ was not increased by PFOA exposure. Activity of mouse and human PPAR γ were not increased by exposure to PFOA. PFOA was found to activate mouse and human PPAR α and mouse PPAR β/δ under the conditions in this study.

Biomarkers for Peroxisome Proliferation. Pastoor et al. (1987) dosed male Crl:CD (SD) BR rats for 1, 3, and 7 days with 0 or 50 mg PFOA/kg/day. Hepatic DNA content, cytochrome P450 content, UDP-glucuronyltransferase, glutathione S-transferase, benzphetamine N-demethylase activity (marker for smooth ER proliferation), and ethoxyresorufin O-deethylase activity (marker for cytochrome P450 induction via the aryl hydrocarbon receptor) were measured from rats dosed 1 and 3 days. Liver microsomes were prepared from rats dosed for 3 days for CAT and CPT activity assays. CAT served as a marker for peroxisome proliferation and CPT was a marker for mitochondrial proliferation. Incorporation of [14 C]acetate into hepatic lipids was used to determine the effect of PFOA on hepatic lipid metabolism. Plasma TC and triacylglycerides was determined from rats dosed for 7 days.

Hepatic DNA content was not increased in treated rats when compared to content in control rats. Cytochrome P450 was significantly increased ($p < 0.05$) and ethoxyresorufin O-deethylase activity was significantly decreased ($p < 0.05$) after treatment for 1 and 3 days. Benzphetamine N-demethylase activity was significantly increased ($p < 0.05$) after treatment with PFOA for 3 days. CAT activity increased 12-fold ($p < 0.05$) and CPT increased twofold ($p < 0.05$) after a 3-day treatment with 50 mg PFOA/kg. No differences were observed among the groups for the

other enzymes. No differences were observed between rats treated for 7 days and control rats in plasma TC or triacylglycerol. Although a significant increase ($p < 0.05$) was observed for [^{14}C]acetate incorporation into triacylglycerols, cholesteryl esters, and polar lipids, there was no difference in the distribution of the incorporated label between control and treated rats. The authors concluded that the lack of increased DNA content, proliferation of smooth ER, and peroxisome proliferation pointed to increased liver weight due to hepatocyte hypertrophy.

Gap Junction Intercellular Communication. Upham et al. (1998, 2009) examined the effects of perfluorinated fatty acids on gap junction intercellular communication (GJIC) in male Fischer 344 rats fed diets containing 0 or 0.02% PFOA (intake 37.9 mg/kg/day) for 1 week and in WB-F344 rat liver epithelial cells. The chain lengths of the perfluorinated fatty acids ranged from 2–10, 16, and 18 carbons. Liver weight in the rats fed diets containing 0.02% PFOA was significantly increased compared to control rat liver weight. No differences were observed in serum AST, ALT, and ALP. PFOA significantly inhibited GJIC in the livers of rats after treatment for 1 week. In WB-F344 cells, GJIC was inhibited by perfluorinated fatty acids with 7–10 carbons within 15 mins of incubation. The inhibition was reversible with full recovery occurring within 30 mins of PFOA removal from media. Extracellular receptor kinase was activated by PFOA within 5 mins of incubation in the cells. Preincubation of cells with the phosphatidylcholine-specific phospholipase C inhibitor D609 partially prevented GJIC inhibition by PFOA. The authors concluded that PFOA, having an 8-carbon chain, inhibited GJIC by activation of extracellular receptor kinase and phosphatidylcholine-specific phospholipase C, but noted that other mechanisms might be involved.

Production of ROS. Takagi et al. (1991) fed male Fischer 344 rats diets containing 0, 10, and 20 mg PFOA/kg for 2 weeks to determine the formation of 8-OH-dG (marker of oxidative DNA damage). Livers and kidneys were removed at necropsy and DNA was isolated from each organ and analyzed. The relative liver and kidney weights were significantly increased ($p < 0.05$) in the treated rats compared to the control. A significant increase in 8-OH-dG liver levels was observed at ≥ 10 mg PFOA/kg. There were no significant differences in 8-OH-dG kidney levels between PFOA-treated and control rats. The authors concluded that PFOA could cause organ-specific oxidative DNA damage.

Hu and Hu (2009) exposed human hepatoma cells, HepG2, to PFOA to evaluate cytotoxic effects. Cells also were exposed to a mixture of PFOA and PFOS to determine antagonistic or synergic effects. The cells were exposed to 0, 50, 100, 150, and 200 μmol PFOA or to 0, 50, 150, and 200 μmol each of PFOA and PFOS. A group of cells also were exposed to 0, 50, 100, 150, and 200 μmol PFOS. The cells were cultured for 24, 48, and 72 hours. Cell viability, apoptosis, ROS, mitochondrial membrane potential, antioxidant enzymes, glutathione content, and differential expression of apoptosis gene regulators p53, Bax, Bcl-2, caspase-3, and caspase-9 genes were evaluated.

Exposure to PFOA or PFOS caused a dose-dependent decrease in viability of HepG2 cells. A nonsignificant dose-dependent increase in apoptosis was observed in the cells cultured with PFOA. However, the combination of PFOA and PFOS showed a significant dose-dependent increase ($p < 0.05$) in apoptosis. Intracellular ROS were significantly increased ($p < 0.05$) in cells cultured with 100, 150, and 200 μmol PFOA or PFOS. HepG2 cells exposed to the mixture of 100 and 200 μmol PFOA and PFOS exhibited a decline in fluorescence intensity in the mitochondrial membrane potential assay, indicating that mitochondrial pathways were involved in the apoptosis observed. Exposure to 100 μmol PFOA significantly decreased ($p < 0.05$) glutathione concentration and glutathione peroxidase activity; and 150 μmol PFOA significantly

increased ($p < 0.05$) the activities of SOD, catalase, and glutathione reductase, and significantly decreased ($p < 0.05$) glutathione peroxidase activity, and glutathione concentration in HepG2 cells. The trend was the same at 200 μmol PFOA, with the exception of GST activity being significantly decreased ($p < 0.05$).

Exposure to PFOA did not change p53, Bax, or caspase-3 expression in HepG2 cells. Expression of Bcl-2 was downregulated and caspase-9 was upregulated in a dose-dependent manner in HepG2 cells following exposure to 50–200 μMol PFOA. The authors proposed that PFOA and PFOS induced cell apoptosis by overwhelming the homeostasis of antioxidative systems, increasing ROS, impacting mitochondria, and changing gene expression of apoptosis gene regulators.

Eriksen et al. (2010) examined ability of PFOA to generate ROS and induce oxidative DNA damage in human HepG2 cells. Cells were incubated with 0, 0.4, 4, 40, 200, 400, 1,000, and 2,000 μmol PFOA and 2',7'-dichlorofluorescein diacetate. Hydrogen peroxide, H_2O_2 , was used as a positive control. A fluorescence spectrophotometer was used to measure ROS production every 15 mins during the 3-hour incubation period in all cultures. The comet assay was used to measure DNA damage in cells exposed to 0, 100, and 400 μmol PFOA for 24 hours. Cytotoxicity was determined by measuring the level of lactate dehydrogenase activity in the cell medium. Exposure to PFOA caused a dose-independent increase (all doses $p < 0.05$) in ROS production in HepG2 cells. Compared to ROS production in negative control cells, PFOA induced a 1.52-fold increase in production. There was no difference in oxidative DNA damage and lactate dehydrogenase activity between PFOA-treated cells and negative control cells. The authors concluded that oxidative stress and DNA damage were probably not relevant to potential adverse effects of PFOA.

Protein Binding. The ability of PFOA to bind to serum proteins for distribution is discussed in section 2.2. PFAS protein binding also can impact cellular function in cases in which the proteins in question are transporters (serum albumin and fatty acid binding protein) or enzymes (lysine decarboxylase) as well as membrane receptors (e.g., members of the PPAR family) and thyroid hormone receptors. The mechanistic studies of the nuclear PPAR α membrane receptors are described in section 3.3.4.

Ren et al. (2015) examined the relative binding affinities of 16 PFASs for the human thyroid hormone receptor's α ligand binding domain (TR α -LBD) using a fluorescence competitive binding assay. Solutions of 1 μmol TR α -LBD were prepared in DMSO. Changes in TR α -LBD tryptophan fluorescence after binding to 10- μmol T3 in the absence or presence of the PFAS was used to determine the binding properties of the PFAS. IC_{50} values were calculated by linear extrapolation between two responses located in the vicinity of a 50% inhibition level. All the PFASs had a lower affinity for the receptor than T3. Affinity of PFOA was less than that for PFDA, PFUnA, PFNA, and PFOS.

ToxCast Assay Results. The Toxicity Forecaster (ToxCast) database is a large high-throughput screening compilation of public *in vitro* and *in vivo* assays on over 9,000 chemicals (USEPA 2015). PFOA was tested in 1,084 assays and was active in 40 (USEPA 2015). Assays with less than 50% efficacy reported or overfitting issues are not included in the summary of results that follows.

Three of the acceptable ToxCast active cytotoxicity assays evaluated the impact of PFOA. All three of these assays are based on one cell type. If there was no cytotoxicity reported for a specific cell type, the AC50 (the minimum concentration with 50% cytotoxicity activity) was used for comparison when reporting the ToxCast results. The lowest recorded AC50 (109 μmol) measured the degradation of microtubules in liver cells at 109 μmol and the highest recorded (123 μmol) measured general cytotoxicity in liver cells.

PFOA activated two of the 21 estrogen related assays in ToxCast; both were ESR1-related. Estrogen and its receptors are essential for sexual development and reproductive function, but also play a role in other tissues such as bone. PFOA induced estrogen response element and inhibited ESR1 at concentrations lower than their AC50 values with concentrations of 33.8 μmol and 47.4 μmol , respectively. This implies that PFOA could have some estrogenic potential; however, due to the small fraction of estrogenic assays activated (10%), any activity is likely weak.

PFOA activated PPARs, PXR, CAR, and retinoic acid receptor (RAR) assays within the ToxCast program. From the PPAR assays, PFOA induced the DNA sequences for PPAR α , PPAR γ , and the peroxisome proliferator hormone response element (PPRE) and antagonized the PPAR γ receptor. The only PPAR assay AC50 value that was above the cell-specific AC50 was that for PPAR γ antagonism at 5.91 μmol . However, it is possible that cytotoxicity occurs due to PPAR induction, or that PPAR cytotoxicity leads to PPAR induction confounding interpretation of the outcome. PFOA induced DNA sequences for PXR (AC50 9.42 μmol) at a concentration lower than the cell-specific AC50. CAR and RAR alpha antagonism also was observed, but the concentrations of 17.57 μmol and 28.45 μmol , respectively, were not below the cell-specific cytotoxicity value. PPAR, PXR, CAR, and RAR pathways are all nuclear receptors that can form heterodimers with one another to induce translation of various genes. Some of these genes are important for development, reproduction, and waste degradation, and could play a role in PFOA-induced cancer.

The ToxCast program examined Cytochrome P450 (CYP) activation associated with PFOA exposure. Although PFOA is not metabolically active, it was found to activate four CYPs: CYP2C18, CYP2C19, and CYP2C9 in human cells and CYP2C11 in rat cells. All of the CYP assays were activated at concentrations lower than the lowest AC50 (109 μmol) but lacked cell-specific AC50s. The CYP2C class of CYPs is involved in the metabolism of xenobiotics such as the following drugs: the antiseizure medication diazepam, beta blocker propranolol, and selective serotonergic reuptake inhibitor citalopram. Though there is no evidence of metabolism of PFOA by these CYPs, it is possible that it acts as a competitive or allosteric inhibitor for known substrates of the CYPs activated. This coupled with PFOA's high affinity for binding to albumin could significantly alter the PKs of various pharmaceutical bound to serum albumin, thus potentially playing a role in increasing systemic toxicity of some pharmaceuticals by increasing the free serum concentration.

PFOA failed to cause toxicity in the *in vivo* fish model for neurological and developmental toxicity. This is important because PFOA induces developmental toxicity in mice and rats *in vivo*.

3.3.5 Structure-Activity Relationship

Bjork and Wallace (2009) compared the PPAR α -dependent transcriptional activation potential of linear perfluorocarboxylic and sulfonic acids in rodent and human hepatic liver cells. The PFAAs tested included perfluorinated carboxylic acids with carbon chain lengths of 2–8 and perfluorinated sulfonic acids with chain lengths of 4–8. Primary rat and human hepatocytes and HEPG2/C3A cells were incubated with 0 and 25 μmol perfluorinated compounds for 24 hours. Expression of Acox, Cyp4a1 (rat), Cyp4a11 (human), Cte/Acot1, and Ddit3 (GADD153) transcripts were determined by quantitative RT-PCR. All the genes are inducible by peroxisome proliferators except Ddit3, which is induced in the presence of direct or indirect DNA damage.

Perfluorinated compounds induced mRNA expression of either Acox or Cte/Acot1 only in rat hepatocytes, and the degree of stimulation of gene expression increased with increasing carbon number. The Cyp4a11 gene was not expressed or stimulated by any of the PFAAs in HepG2/C3A cells. However, this gene expression was stimulated by perfluorinated exposure in both rat and human hepatocytes with the perfluorocarboxylates showing a chain-length-dependent structure activity relationship. The study results suggest that the PPAR α -related changes in gene expression induced by perfluorinated compounds in primary rat hepatocytes are directly related to the carbon chain length and appear to be stronger for the carboxylic acids (i.e., PFOA) than the sulfonates (i.e., PFOS). There was no induction in expression of Acox and Cte/Acot 1 in either primary or transformed human liver cells in culture. The authors suggested that the PPAR α mediated peroxisome proliferation observed in rodent liver might not be relevant as an indicator to human risk.

Wolf et al. (2008b) tested PFAAs, including PFOA, to determine if mouse and human PPAR α activity could be induced in transiently transfected COS-1 cell assays. COS-1 cells were transfected with either a mouse or human PPAR- α receptor-luciferase reporter plasmid and, after 24 hours, were exposed to either negative controls (water or 0.1% DMSO), a positive control (Wyeth 14,643), or PFOA at 0.5–100 μmol . Other concentrations of PFAAs were used but not provided in this report. At the end of 24 hours of exposure, the luciferase activity was measured. The positive and negative controls had the expected results. A lowest observed effect concentration (LOEC) and no observed effect concentration (NOEC) were determined for each PFAA. In the study, the mouse PPAR α was more responsive than the human. Also, carboxylates induced higher mouse and human PPAR α activity than the sulfonates. In this study, the NOEC for PFOA was 0.5 μmol in the mouse and 5 μmol in humans; the LOEC was 1 μmol (0.43 $\mu\text{g}/\text{mL}$) in the mouse and 10 μmol (4.3 $\mu\text{g}/\text{mL}$) in humans.

A similar study included additional PFAAs (Wolf et al. 2012). Transfected cells were incubated with PFAAs at concentrations of 0.5 to 100 μmol , vehicle (water or 0.1% DMSO as negative control) or with 10 μmol Wyeth 14,643 (positive control) on each plate. Assays were performed with three identical plates per compound per species with nine concentrations per plate and eight wells per concentration. Cell viability was assessed using the Cell Titer Blue cell viability kit and read in a fluorometer. The positive and negative controls had the expected results. All cells transfected with either human and mouse PPAR α responded to the PFAAs. Again, the carboxylates were stronger inducers than the sulfonates, and the mouse PPAR α was more reactive than the human PPAR α . The study also provided the C_{20max} values for each PFAA (the concentration at which the PFAA produced 20% of the maximal response elicited by the most active PFAA). For PFOA, this was 6 μmol in mouse PPAR α and 7 μmol in human PPAR α . For comparison, PFOS was 94 μmol and 262 μmol , respectively.

3.4 Hazard Characterization

3.4.1 Synthesis and Evaluation of Major Noncancer Effects

Serum Lipids. Because of the structural similarities between linear perfluorinated acids and the short- and medium-chain fatty acids, the potential for these chemicals to cause elevated serum lipids has been an area of considerable interest. High levels of serum lipids (TC and LDL) are risk factors for cardiovascular disease in humans, including IHD, a condition in which blood flow to the heart is decreased through the development of atherosclerotic plaque or clots in the cardiac arteries.

The association between PFOA and serum lipids has been examined in several studies in different populations. Cross-sectional and longitudinal studies in occupational settings (Costa et al. 2009; Olsen et al. 2000, 2003; Olsen and Zobel 2007; Sakr et al. 2007a, 2007b; Steenland et al. 2015) and in the high-exposure community (the C8 Health Project study population) (Fitz-Simon et al. 2013; Frisbee et al. 2010; Steenland et al. 2009; Winquist and Steenland 2014a) generally observed positive associations between serum PFOA and TC in adults and children (aged 1–< 18 yrs); most of these effect estimates were statistically significant. Although exceptions to this pattern are present (i.e., some of the analyses examining incidence of self-reported high cholesterol based on medication use in Winquist and Steenland 2014a and in Steenland et al. 2015), the results are relatively consistent and robust. Similar associations were seen in analyses of LDL, but were not seen with HDL. The range of exposure in occupational studies is large (means varying between 0.4 and > 12 µg/mL), and the mean serum levels in the C8 population studies were around 0.08 µg/mL. Positive associations between serum PFOA and TC (i.e., increasing lipid level with increasing PFOA) were observed in most of the general population studies at mean exposure levels of 0.002–0.007 µg/mL (Eriksen et al. 2013; Fisher et al. 2013; Geiger et al. 2014a; Nelson et al. 2010; Starling et al. 2014). The interpretation of these general population results is limited, however, by the moderately strong correlations (Spearman $r > 0.6$) and similarity in results seen for PFOS and PFOA. The most recent update of disease incidence in workers in the C8 Health Project study population identified 35 cases of nonhepatitis liver disease (with medical validation) (Steenland et al. 2015); no association was seen with cumulative exposure when analyzed without a lag (HRs by quartile 1.0, 0.58, 1.43, 1.20; trend $p = 0.86$ for log cumulative exposure), but there was a possible trend in the analysis using a 10-year lag (HRs by quartile 1.0, 1.46, 2.13, and 2.02; trend $p = 0.40$).

Cholesterol and/or triglycerides were monitored in only a few of the animal studies, which did not all measure concurrent serum PFOA levels. Information on serum lipids from animal studies has received less attention than in the human population because of the fact that decreases in triglycerides, cholesterol, and lipoprotein complexes are an expected consequence of PPAR α activation in rodents. The PPAR α response in animals tends to lower rather than raise serum cholesterol and associated lipid levels. Peroxisomes are subcellular organelles that increase beta oxidation of long-chain fatty acids using a beta oxidation pathway that is not linked to adenosine triphosphate (ATP) production and release the shortened fatty acids to the cytosol as an endproduct for export in VLDLs or hepatic ATP-production via mitochondrial beta oxidation (Garrett and Grisham 1999). PPAR α activation also stimulates metabolic changes that lower hepatic cholesterol. The effects of human PPAR α activation are much less pronounced than those in rats and mice.

Nakamura et al. (2009) and Minata et al. (2010) examined the lipid endpoints relative to the mouse strain's PPAR α status and PFOA exposure. Nakamura et al. (2009) found that mice with a normal PPAR α receptor had significantly increased levels of cholesterol and triglycerides in liver but not plasma at a LOAEL of 0.3 mg/kg/day. However, there were no differences in serum or liver cholesterol or triglycerides between PFOA-treated mice with a humanized PPAR α receptor or PPAR α -null mice (NOAEL= 0.3 mg/kg/day) and their respective controls. The study by Minata et al. (2010) used higher doses than Nakamura et al. (2009) and found that TC was significantly decreased (LOAEL= 10.8 mg/kg/day; whole blood 47 μ g/mL) and total triglycerides significantly increased (LOAEL= 5.4 mg/kg/day; whole blood 21 μ g/mL) in wild-type mice. In the PPAR α -null mice, the TC was significantly decreased for the 5.4- and 10.8-mg/kg/day doses but significantly increased for a 21.6-mg/kg/day dose while total triglycerides were significantly increased at all doses; these doses corresponded to whole blood PFOA levels of 13, 36, and 71 μ g/mL, respectively. Rosen et al. (2007) found that PFOA activated genes for fatty acid catabolism, cholesterol biosynthesis; bile acid biosynthesis; and lipoprotein, steroid, and glucose metabolism in fetal livers. When comparing the response in PPAR α wild-type to null mice (Rosen et al. 2008b), 62 of 81 activated genes were the same for both strains and were ones involved with lipid metabolism.

Martin et al. (2007) identified a 45–72% decrease in serum cholesterol after treatment of male Sprague-Dawley rats with 20 mg PFOA/kg/day for up to 5 days (serum PFOA 245 μ g/mL after 3 days), and Loveless et al. (2008) reported decreased TC, HDL, and non-HDL in male CD rats after doses of 0.3 and 1 mg/kg/day for 28 days. Triglycerides were decreased in the rats at \geq 0.3 mg/kg/day. De Witt et al. (2009) found a dose-dependent decrease in triglyceride levels in female C57BL/6N mice exposed to 0, 7.5, and 15 mg PFOA/kg bw in drinking water for 10 days. In male CD-1 mice, TC, HDL, and triglycerides were decreased at 10 and 30 mg/kg/day (Loveless et al. 2008). In pregnant female ICR mice, triglyceride, TC, and free fatty acids were significantly decreased at 10 mg/kg (Yahia et al. 2010). Elcombe et al. (2010) found a significant decrease in cholesterol in male Sprague-Dawley rats following a 7- or 28-day exposure to 300 ppm PFOA in the diet with a resulting serum level of 252 μ g/mL at 28 days. Accordingly, there is not a high degree of concordance between the lipidemic effects of PFOA as noted in human epidemiology studies and those seen in animals.

Filgo et al. (2015) found a trend for increased liver Ito (fat) cell atrophy and lesion severity across the doses in CD-1 and SV-129 mice at 18 months. PFOA exposure occurred only through the dam during gestation and lactation in this study. This observation suggests that liver steatosis could be a concern late in life for animals exposed to PFOA gestationally and during their early postnatal period. However, the 18-month fat accumulation could also be related to normal aging and/or dietary fat intakes across the animal's lifetime (Quist et al. 2015). Tan et al. (2013) found that the fat content of the diet was an important variable in determining the impact of PFOA (5 mg/kg/day) on liver and serum lipids. Intake of an HFD plus PFOA increased liver triglycerides and serum free fatty acids compared to an RFD plus PFOA but had no impact on liver cholesterol concentrations. Serum cholesterol was not monitored.

Hepatic Effects. Both the human and animal studies suggest effects on the liver as indicated by increases in liver enzymes. The results of the occupational studies provide evidence of an association with increases in serum AST, ALT and GGT, with the most consistent results seen for ALT. The associations were not large and could depend on the covariates in the models, such as BMI, use of lipid-lowering medications, and triglycerides (Costa et al. 2009; Olsen et al. 2000, 2003; Olsen and Zobel 2007; Sakr et al. 2007a, 2007b). Two population-based studies of highly

exposed residents in contaminated regions near a fluorochemical industry in West Virginia have evaluated associations with liver enzymes, and the larger of the two studies reported associations of increasing serum ln ALT and ln GGT levels with increasing serum PFOA concentrations (Emmett et al. 2006; Gallo et al. 2012). A cross-sectional analysis of data from NHANES, representative of the U.S. national population, also found associations with ln PFOA concentration with increasing serum ALT and ln GGT levels. Serum bilirubin was inversely associated with serum PFOA in the occupational studies. A U-shaped exposure-response pattern for serum bilirubin was observed among the participants in the C8 Health Project, which might explain the inverse associations reported for occupational cohorts. Overall, an association of serum PFOA concentration with elevations in serum levels of ALT and GGT has been consistently observed in occupational, highly exposed residential communities, and the U.S. general population. The associations are not large in magnitude, but indicate the potential to affect liver function.

The data from animal studies for increases in ALT and AST support the findings in human epidemiology studies; however, the animal studies for both aminotransferases lacked serum PFOA measurements for comparison with the human serum data. Concurrent with the evidence in animals of damage to liver cells, levels of some membrane transport proteins were altered. In mice, the increased expression of MRP3 and MRP4 (Maher et al. 2008) and the decreased expression of OATPs (Cheng and Klaassen 2008) favor excretion of PFOA into the bile. Competition of PFOA with bile acids for transport could alter the excretion of the cholesterol derivatives excreted in bile.

In animal studies, serum levels of ALT and/or AST were significantly increased indicating apoptosis or necrosis of liver cells (Butenhoff et al. 2012; Minata et al. 2010; Son et al. 2008). Increased levels of ALT were observed at a LOAEL of 2.65 mg/kg/day in ICR mice by Son et al. (2008). Yahia et al. (2010) reported significantly increased ALT, GGT, AST, and ALP in PFOA-exposed (10 mg/kg) pregnant ICR mice. Total protein, albumin, and globulin were significantly decreased in the same mice.

No evidence of liver damage has been found in the human epidemiology studies with the exception of the few enzyme changes discussed above. In most PFOA animal studies (e.g., monkeys, rats, and mice), short-term and chronic exposure caused a dose-related increase in liver weight as at least one of the co-occurring effects (Butenhoff et al. 2002, 2004a, 2012; DeWitt et al. 2009; Elcombe et al. 2010; Minata et al. 2010; Pastoor et al. 1987; Perkins et al. 2004; Son et al. 2008; Wolf et al. 2008a). Increased liver weights were observed in mice that are both active and null for PPAR α activation (Albrecht et al. 2013; Minata et al. 2010; Wolf et al. 2008a). The histological characteristics of the liver differed in the mice with and without the PPAR α receptor, but the liver weight increase was the same. Liver effects were seen in mice with an active PPAR α receptor at doses as low as 0.3 mg/kg/day (Nakamura et al. 2009) and 1 mg/kg/day in the null mice (Wolf et al. 2008a).

Histological examination of liver tissues from PFOA-exposed wild-type mice and PPAR α -null mice were distinctly different from their respective controls (Minata et al. 2010; Wolf et al. 2008a). In the case of the wild-type PFOA-exposed mice, there was less rough ER than in controls and more lipid-like vacuoles scattered throughout the cytoplasm. The PFOA-exposed PPAR α -null mice had proliferation of smooth ER and limited rough ER and Golgi bodies compared to their controls. The PPAR α -null control mice had the scattered lipid-like vacuoles seen in the wild-type PFOA exposed mice; however, their lipid-like vacuoles were considerably larger than those seen in the wild-type animals and occupied a considerable volume within the

cytoplasm. The vacuoles in the PPAR α -null PFOA-exposed mice were hypothesized to be filled with PFOA as a consequence of its uptake into the cell without dispersion or assimilation.

Similarly, Albrecht et al. (2013) observed centrilobular hepatocellular hypertrophy in mouse dams given 3 mg/kg on GDs 1–17, but the morphological features differed slightly between wild-type, PPAR α -humanized, and PPAR α -null mice. In wild-type mice, hypertrophy was characterized primarily by centrilobular hepatocytes with increased amounts of densely eosinophilic and coarsely granular cytoplasm consistent with increased peroxisomes. In null mice, hypertrophy was generally less prominent than seen in wild-type mice, and affected hepatocytes had pale eosinophilic, finely granular-to-amorphous cytoplasm. The morphological features of centrilobular hepatocytes in humanized mice were intermediate between those observed in wild-type and null mice. The lesion was graded as mild in wild-type mice, minimal in null mice, and minimal or mild in humanized mice. An additional finding in PFOA-treated null and humanized mice, but not in wild-type mice, was the presence of few clear, discrete vacuoles within the cytoplasm of centrilobular hepatocytes.

Hepatocellular hypertrophy and an increased liver-to-body weight ratio are common findings in rodents when PPAR α activation leads to peroxisome proliferation and these effects are considered nonadverse in wild-type strains when they occur. Hepatic necrosis, effects on bile ducts, and other signs of liver damage unrelated to PPAR α activation observed in conjunction with the increased liver weight and hepatocellular hypertrophy are sufficient to justify the liver weight and hypertrophy as adverse (Hall et al. 2012). Low-level necrotic cell damage was observed in the Perkins et al. (2004) rat study and in the Loveless et al. study (2008) in CD rats at 10 mg/kg/day and CD1 mice at 1 mg/kg/day. In the Perkins et al. study (2004), there was a slight increase in coagulative necrosis at 1.94 and 6.5 mg/kg/day when compared to the control and lower doses. Some hepatocellular necrosis also was observed in conjunction with hepatocellular hypertrophy and increased liver weight in F1 male rats from the Butenhoff et al. (2004a) two-generation study at 3 mg/kg/day.

Minata et al. (2010) reported degenerative histological changes in the bile ducts of PPAR α -null mice at doses ≥ 10.6 mg/kg/day and Loveless et al. (2008) observed bile duct hyperplasia in CD1 mice at doses ≥ 10 mg/kg/day. PPAR α -null mice had an increased hepatocyte PCNA labeling index at a dose of 10 mg/kg/day (Wolf et al. 2008a). When considering the studies in animals with and without the active PPAR α receptor, it is clear that PFOA has some effects of potential toxicological significance that appear to be independent of PPAR α activation.

Kidney and Other Organ Effects. Overall, studies of occupational cohorts (Costa et al. 2009), a highly exposed community (Steenland et al. 2010; Watkins et al. 2013), and the U.S. general population (Shankar et al. 2011) that evaluated uric acid levels or eGFR as measure of kidney function found associations with decreased function. Reverse causality as an explanation cannot be ruled out in studies using serum PFOA as a biomarker of exposure, as a low GFR would diminish the removal of PFOA from serum for excretion by the kidney.

Some studies in animals have shown effects on the kidney, mainly increased organ weight in male rats, but the studies lacked concurrent PFOA serum levels and histological examination of the kidney tissues. In general, kidney effects in rats occurred at doses similar to those resulting in liver effects.

Increases in absolute and relative-to-body kidney weights occurred in rats given 5 mg/kg/day (lowest dose tested) for 28 days (Cui et al. 2009). In a two-generation study, F0 and F1 males

had significantly increased absolute kidney weight at 1 and 3 mg/kg/day, but significantly decreased organ weight at 30 mg/kg/day. Organ weight-to-terminal body weight ratios for the kidney were statistically significantly increased at ≥ 1 mg/kg/day. Kidney weight-to-brain weight ratios were significantly increased at 1, 3, and 10 mg/kg/day, but decreased at 30 mg/kg/day, following the trends in absolute weights (Butenhoff et al. 2004a). In the high-dose group, absolute and relative kidney weight changes occurred in a pattern typically associated with decrements in body weight. However, in the lower dose groups kidney weight, consistently displayed an increase (absolute and relative to body and brain weights), suggesting an induction of transporters for renal removal of the foreign molecule. The differential expression of transporters in the kidney of rats has been shown to be under hormonal control with males having lower levels of export transporters compared with females (Kudo et al. 2002).

In both the Cui et al. (2009) and Butenhoff et al. (2004a) studies, PFOA was administered by daily gavage. No changes in kidney weight were found with dietary administration with a resulting dose of 14.2 mg/kg/day to male rats for 2 years (Butenhoff et al. 2012).

In general, effects on organs other than the liver tend to occur at doses higher than those that affect the liver. Lung effects, including pulmonary congestion, have been observed in male Sprague-Dawley rats (LOAEL = 5 mg/kg/day) (Cui et al. 2009). Increased thickness and prominence of the adrenal zona glomerulosa and vacuolation in the cells of the adrenal cortex were observed in male rats fed 10 mg/kg/day for approximately 56 days (Butenhoff et al. 2004a).

Thyroid Effects. Three large studies provide support for an association between PFOA exposure and incidence or prevalence of thyroid disease in female adults or children, but not in males (Lopez-Espinosa et al 2012; Melzer et al. 2010; Winquist and Steenland 2014b). In addition, associations between PFOA and TSH were also seen in pregnant females with anti-TPO antibodies (Webster et al. 2014). However, generally null associations were found between PFOA and TSH or thyroid hormones (T4 or T3) in people who have not been diagnosed with thyroid disease.

Effects of PFOA on thyroid hormones in animals are generally not as well characterized as those of PFOS. Butenhoff et al. (2002) evaluated the toxicity of PFOA in male cynomolgus monkeys during 6 months of oral administration and reported that levels of total T3 and FT3 in circulation were reduced significantly in the 30/20 mg/kg/day treatment group. The effect seen as early as 5 weeks after initiation of treatment, 2 weeks after the dose was lowered to 20 mg/kg/day. Recovery of T3 deficits was noted upon cessation of chemical treatment once the serum level of PFOA returned to baseline 90 days later. Serum total T4, FT4, and TSH were not altered throughout the study. The preferential effects of PFOA on serum T3 and a lack of a TSH compensatory response are similar to those observed with PFOS.

Martin et al. (2007) showed that serum total T4 and FT4 were markedly and abruptly depressed (~ 80%) in adult male rats 1 day after oral gavage treatment with PFOA (20 mg/kg); serum T3 was also reduced (25%), although to a lesser extent. These findings were confirmed when both male and female rats were given PFOA (10 mg/kg) daily for 3 weeks and serum thyroid hormones were monitored (Lau, personal communication) (Martin et al. 2007). Serum total T4 and FT4 were profoundly depressed (>85%) and T3 less so (~ 25%) in male rats, but serum TSH levels were not altered significantly. These hormonal changes were noted when serum PFOA level reached about 67 $\mu\text{g}/\text{ml}$. The dose-response relationship of serum total T4 with PFOA exposure has yet to be fully evaluated and the lowest effective dose remains unknown.

None of the thyroid hormones were affected by PFOA in mature female rats, primarily because these animals were able to clear the chemical effectively (with half-life estimate of 2–4 hours compared to that of 6–7 days for male rats). This suggests that the thyroid disrupting effects of PFOA are directly related to endogenous accumulation of the chemical and could be relevant to humans because of the long PFOA human half-life.

Displacement of T4 from binding to TTR has been proposed as a possible mechanism to account for the hypothyroxinemia in rats. However, although PFOA binds to human TTR, its binding affinity is only one-fifteenth of that of the natural ligand T4 (Weiss et al. 2009). Based on a toxicogenomic analysis of rat liver after an acute exposure to PFOA, Martin et al. (2007) suggested a possible role of peroxisome proliferators in the thyroid hormone imbalance, although this hypothesis has yet to be explored in detail.

Hyperglycemia. Several human epidemiology studies have examined PFOA in relation to diabetes (incidence or prevalence) or measures of hyperglycemia. These studies do not show a pattern of results that suggest an association between PFOA and diabetes or hyperglycemia in occupational settings (Costa et al. 2009; Olsen et al. 2000, 2003; Sakr et al. 2007a; Steenland et al. 2015), in the high-exposure community population (MacNeil et al. 2009), or in the general population (Lin et al. 2009; Nelson et al. 2010).

Hines et al. (2009) found no differences in glucose tolerance tests at 15–16 weeks and at 17 months of age in PFOA-exposed CD-1 mice, but did observe significantly increased serum leptin and insulin levels at 21 and 31 weeks of age, suggesting that the insulin resistance mechanistic pathway could be affected by PFOA. Conversely, Quist et al. (2015) found no dose-related impact on serum leptin in CD-1 pups from the Hines et al. study (2009) when examined on PND 91 for the mice on an RFD and on an HFD fasted for 4 hours before serum collection. In the animals on a HFD that did not fast before serum collection, there was a trend towards a dose-related decrease in serum leptin. Thus, the fat content of the diet and the timing of serum collection are important variables that can influence study results relative to leptin levels and indicators of insulin resistance.

Nervous System Effects. The data pertaining to neurotoxicity (including neurodevelopmental effects) of PFOA are limited, but do not indicate the presence of associations between PFOA and a variety of outcomes. Fei et al. (2008b) found no association between maternal serum PFOA concentrations and fine motor skills, gross motor skills, and cognitive abilities of children aged 6 and 18 months. Fei and Olsen (2011) found no association between behavioral or coordination problems in children aged 7 years and prenatal PFOA exposure. Epidemiology studies of children derived from the NHANES and C8 populations found a weak statistical association between serum PFOA with parental reports of ADHD (Hoffman et al. 2010; Stein et al. 2013).

One animal study (Johansson et al. 2009) suggests a potential effect on habituation and activity patterns in NMRI mice treated on PND 10 with a single dose of PFOA and evaluated at 2 and 4 months of age (LOAEL=0.58 mg/kg). The *in vivo* observations were supported by changes in the expression of a variety of neurologically active brain proteins in the treated pups (Johansson et al. 2009). The offspring of C57BL/6/Bkl dams fed 0.3 mg PFOA/kg/day throughout gestation had detectable levels of PFOA in their brains at birth (Onishchenko et al. 2011). Behavioral assessments of the offspring starting at 5 weeks of age revealed gender-related differences in exploratory behavior patterns. In the social group setting, the PFOA-exposed males were more active and PFOA-exposed females were less active than their respective controls. The PFOA-exposed males also had increased activity counts compared to control males.

in circadian activity experiments. The results of an *in vitro* study of hippocampal synaptic transmission and neurite growth in the presence of long-chain perfluorinated compounds showed that 50 and 100 μmol PFOA increased spontaneous synaptic current and had an equivocal impact on neurite growth (Liao et al. 2009a, 2009b). These data suggest a need for additional studies of the effects of PFASs, including PFOA, on the brain.

Reproductive and Developmental Effects. There have been numerous human studies examining PFOA exposure and reproductive and/or developmental effects in both humans and animals. A series of studies in the high-exposure C8 Health Project study population have reported associations between PFOA exposure and pregnancy-induced hypertension or preeclampsia (Darrow et al. 2013; Savitz et al. 2012a, 2012b; Stein et al. 2009). Each of these studies provides evidence of an association between PFOA exposure and risk of pregnancy-induced hypertension or preeclampsia, with the most robust findings from the methodologically strongest study (Darrow et al. 2013).

The association between PFOA and birth weight has been examined in numerous human studies. Most studies measured PFOA using maternal blood samples taken in the second or third trimester or in cord blood samples. Studies on the high-exposure C8 community population (Darrow et al. 2013; Nolan et al. 2009; Stein et al. 2009; Savitz et al. 2012a, 2012b) have not observed associations between PFOA and either birth weight among term births or the risk of low birth weight among all (singleton) births. In contrast, several analyses of general populations indicate a negative association between PFOA levels and birth weight (Apelberg et al. 2007; Fei et al. 2007; Maisonet et al. 2012), while others did not attain statistical significance (Chen et al. 2012; Hamm et al. 2010; Monroy et al. 2008; Washino et al. 2009). A meta-analysis of many of these studies found a mean birth weight reduction of 19 g (95% CI: -30, -9) per each 1-unit (ng/mL) increase in maternal or cord serum PFOA levels (Johnson et al. 2014). However, when low GFR was accounted for in PBPK simulations by Verner et al. (2015), the association reported between PFOA and birth weight is less than that found in their meta-analysis of the epidemiology data. The study authors reported that the actual association might be closer to a 7-g reduction (95% CI: -8, -6). Verner et al. (2015) also showed that, in individuals with low GFR, there are increased levels of serum PFOA and lower birth weights. This suggests that a portion of the association between PFOA and birth weight could be confounded by low maternal GFR under conditions such as preeclampsia and pregnancy-induced hypertension. While there is some uncertainty in the interpretation of the observed association between PFOA and low GFR with birth weight, given the available information, the association between PFOA exposure and reduced birth weight observed for the general population is plausible. In humans with low GFR, the impact on body weight is likely due to a combination of the low GFR and the serum PFOA.

Two studies examined development of puberty in females in relation to prenatal exposure to PFOA as measured through maternal or cord blood samples in follow-up of pregnancy cohorts conducted in England (Christensen et al. 2011) and in Denmark (Kristensen et al. 2013). The results of these two studies are conflicting, with no association (or a possible indication of an earlier menarche seen with higher PFOA) in Christensen et al. (2011), and a later menarche seen with higher PFOA in Kristensen et al. (2013). Another study examined PFOA exposure measured concurrently with the assessment of pubertal status (Lopez-Espinosa et al. 2011). An association between later age at menarche and higher PFOA levels was observed, but the interpretation of this finding is complicated by the potential effect of puberty on the exposure biomarker levels (i.e., reverse causality).

Limited data suggest a correlation between higher PFOA levels ($>0.02 \mu\text{g/mL}$) in females and decreases in fecundity and fertility (Fei et al. 2009; Vélez et al. 2015), but there are no clear effects of PFOA on male fertility endpoints ($0.0035\text{--}0.005 \mu\text{g/mL}$) (Joensen et al. 2009, 2013).

Knox et al. (2011) found that the odds of having experienced menopause were significantly higher in the highest PFOA quintile group relative to the lowest PFOA group. Two studies found delayed puberty in females (Kristensen et al. 2013; Lopez-Espinosa et al. 2011), but reverse causality needs to be considered. However, Christensen et al. (2011) found no association between puberty and PFOA exposure in children of the Avon Longitudinal Study of Parents and Children in the United Kingdom. Removal of PFOA with the start of monthly menstruation and the cessation of this route with menopause or hysterectomy are additional factors that can influence serum PFOA levels that are the result of the developmental milestones rather than a cause (Taylor et al. 2014; Wong et al. 2014). Costa et al. (2009) found no association between serum PFOA concentration and estradiol or testosterone in workers at a PFOA production plant.

Measures of postnatal development and behavior in children were not associated with PFOA levels in the mother ($0.001\text{--}0.0057 \mu\text{g/mL}$) (Andersen et al. 2010, 2013; Fei et al. 2008b; Fei and Olsen 2011; Høyer et al. 2015a, 2015b). Fei et al. (2008b) found no association between maternal PFOA concentration and fine motor skills, gross motor skills, and cognitive skills in offspring at 6 and 18 months of age. Fei and Olsen (2011) also found no association between prenatal PFOA exposure and behavior or coordination problems in children aged 7 years. The age at which children reached developmental milestones did not show any relationship to maternal plasma PFOA concentration. Halldorsson et al. (2012) found that low-dose developmental exposures to PFOA resulted in obesogenic effects in female offspring at 20 years.

Among the animal studies, there was no effect of PFOA on reproductive or fertility parameters in rats (Butenhoff et al. 2004a; York et al. 2010), but effects on male fertility were observed in male mice (Lu et al. 2015). In mouse gavage studies, decreased body weight and decreased neonatal survival were observed at $\geq 1 \text{ mg/kg/day}$, increased full litter resorptions and increased stillbirths were observed at $\geq 5 \text{ mg/kg/day}$, increased time to parturition was observed at $\geq 10 \text{ mg/kg/day}$, and decreased maternal weight gain was observed at $\geq 20 \text{ mg/kg/day}$ for exposures lasting from GD1–17 (Abbott et al. 2007; Lau et al. 2006; White et al. 2007; Wolf et al. 2007).

Postnatal development also has been studied extensively in rats and mice as discussed below. A separate group of studies in mice focused on mammary gland development in dams and female offspring. Both species showed some indication of potential developmental toxicity. Doses that elicited a response were higher in rats compared with in mice. The species differences in dose response are likely related to half-life differences of hours for the female rat and days-to-weeks for the female mouse.

Reduced postnatal growth leading to developmental delays was observed in both rats and mice. A two-generation diet study in rats resulted in significantly decreased body weight gain prior to weaning and delayed sexual maturity in the first generation males and females at 30 mg/kg/day (Butenhoff et al. 2004a). For treatment beginning on PND 21, delayed vaginal opening was also observed in BALB/c mice at $\geq 1 \text{ mg/kg/day}$ and in C57BL/6 mice at $\geq 5 \text{ mg/kg/day}$, although body weight was not decreased until doses of $\geq 10 \text{ mg/kg/day}$ in both strains (C. Yang et al. 2009). Cross-fostering studies in mice showed that gestational PFOA exposure maximized decreased postnatal body weight, delayed eye opening, delayed body hair growth, and decreased survival in the offspring (Wolf et al. 2007). Restricted exposure studies

showed that gestational exposure to PFOA over differing gestational time periods led to differing offspring effects (Wolf et al. 2007). The longer the gestational exposure, the greater the body weight deficit in the male and female pups over PND 2–22. In males, the difference in body weight persisted until PND 92. Delayed eye opening and body hair growth were observed at 5 mg/kg/day in offspring exposed GD 7–17 or 10–17, but decreased postnatal survival was observed at the same dose in offspring exposed GD 15–17.

Two developmental studies compared wild-type mice with PPAR α -null mice, but results are inconclusive. One study revealed that the litter resorptions were independent of PPAR α expression (≥ 5 mg/kg), while decreased neonatal survival (0.6 mg/kg) and delayed eye opening (1 mg/kg) were dependent upon PPAR α expression (Abbott et al. 2007). These results are only partially supported by Albrecht et al. (2013), who used a single dose of 3 mg/kg. They found decreased pup survival only in wild-type mice, but no differences in litter resorptions or eye opening between wild-type and null mice. Albrecht et al. (2013) did not find effects on pup survival in PPAR α -humanized mice, suggesting that the mouse PPAR α could be involved in the etiology of PFOA-induced neonatal mortality.

Qualitative assessment found delayed mammary gland development of female CD1 mouse pups following maternal doses ≥ 0.01 mg PFOA/kg in Macon et al. (2011) and Tucker et al. (2015). Macon et al. (2011) also found significant differences from controls in quantitative measures of longitudinal and lateral growth and numbers of terminal end buds at 1 mg/kg/day. However, Albrecht et al. (2013) found no significant differences in the average length of mammary gland ducts and the average number of terminal end buds per mammary gland per litter in female pups of PPAR α wild-type, PPAR α -null, or hPPAR α sv/129 mice following a maternal dose of 3 mg/kg, using an approach to scoring that lacked a qualitative component adjustment such as that used by Macon et al. (2011).

The approach to scoring mammary gland development was not consistent across studies, and little information was provided on the qualitative components of the scores. This makes comparisons across studies difficult. Statistical significance was attained at higher dose levels for the quantitative portion of the Macon et al. (2011) scoring protocol than for the qualitative component of the score. The process used to score the qualitative developmental score by Macon et al. (2011) was not described. Tucker et al. (2015) found that CD-1 mice were considerably more sensitive to effects on mammary gland development (LOAEL = 0.01 mg/kg/day) than C57BL/6 mice (NOAEL 0.1 mg/kg/day). Scoring was conducted using the Macon et al (2011) approach.

White et al. (2011) used doses of 0 and 1 mg PFOA/kg/day to F0 dams throughout gestation with and without the addition of drinking water containing 5 ppb PFOA beginning on GD 7 and continuing the contaminated drinking water during the production of two more generations; no persistent significant differences were found in the body weights of the pups in the F1 and F2 generations for the pups receiving 1 mg/kg/day, indicating a poor correlation between mammary duct branching patterns and the ability to support pup growth during lactation. The 5 mg/kg/day dose did have an impact on body weight. Albrecht et al. (2013) also found no significant impacts on pup body weight in their one-generation assay at a dose of 3 mg/kg/day. Despite the diminished ductal network assessed in the qualitative mammary gland developmental score of the dams in White et al. (2011), milk production was sufficient to nourish growth in the exposed pups as reflected in the body weight measurements compared to controls. The MoA for PFOA-induced delayed mammary gland development is unknown and requires further investigation.

At doses of 5 and 10 mg/kg/day, mammary gland development was delayed in BALB/c mice (C. Yang et al. 2009). In C57BL/6 mice, mammary gland development was accelerated at 5 mg/kg/day, but delayed at 10 mg/kg/day, indicating strain differences in pubertal mammary gland development following a dose of 5 mg/kg/day. Y. Zhao et al. (2010) showed that 5 mg PFOA/kg/day stimulates mammary gland development in C57BL/6 mice by promoting steroid hormone production in the ovaries and increasing mammary gland growth factor levels.

Immune Effects. Associations between prenatal, childhood, or adult PFOA exposure and risk of infectious diseases (as a marker of immune suppression) have not been consistently seen, although there was some indication of effect modification by gender (i.e., associations seen in female children but not in male children) (Fei et al. 2010a; Granum et al. 2013; Looker et al. 2014; Okada et al. 2012).

The WHO guidelines for immunotoxicity risk assessment recommend measures of vaccine response as a measure of immune effects, with potentially important public health implications (WHO 2012). Three studies have examined associations between maternal and/or child serum PFOA levels and vaccine response (measured by antibody levels) in children (Grandjean et al. 2012; Granum et al. 2013) and adults (Looker et al. 2014). The study in adults was part of the high-exposure community C8 Health Project; a reduced antibody response to one of the three influenza strains tested after receiving the flu vaccine was seen with increasing levels of serum PFOA; these results were not seen with PFOS. The studies in children were conducted in general populations in Norway and in the Faroe Islands. Decreased vaccine response in relation to PFOA levels was seen in these studies, but similar results also were seen with correlated PFASs (e.g., PFOS).

Several animal studies demonstrate effects on the spleen and thymus as well as their cellular products (B lymphocytes and T-helper cells) in several strains of mice. Studies by Yang et al. (2000, 2001, 2002b) and DeWitt et al. (2008) were conducted using relatively high PFOA doses (~30–40 mg/kg/day). In each study, the PFOA-treated animals exhibited significant decreases in spleen and thymus weights as well as in splenocyte and thymocyte populations at various stages of differentiation. Recovery usually occurred within several days of cessation of PFOA dosing. However, when the response of C57BL/6 Tac PPAR α mice was compared to wild-type of the same strain, the KO mice showed no response of both spleen and thymus weights at 30 mg/kg/day, whereas there was a response in the wild-type strain (DeWitt et al. 2015). Both strains showed an increase in IgM in response to a SRBC injection. The 30-mg/kg/day dose was the LOAEL for the KO mice and 7.5 mg/kg/day was the response level for the wild-type strain. Thus the suppression of the immune system is not totally a PPAR α -related response. In a similar experiment (Yang et al. 2002a), no significant changes in spleen weight or cellularity were observed in PPAR α -null mice as compared to wild-type mice, but there was a small and significant decrease in thymus weight and cellularity compared to controls.

DeWitt et al. (2008) used different functionality assays in their study in C57Bl/6 mice. The IgM response to SRBC was suppressed by 20% when mice were immunized immediately after exposure to the initial dose of 30 mg PFOA/kg/day ceased. However, there was no significant increase in the response to BSA 4 days post-PFOA exposure or in the IgG response to SRBC 15 days post-PFOA exposure. These results are indicative of recovery once PFOA exposures have ceased.

DeWitt et al. (2008) followed their initial study of PFOA with one designed to examine the dose response for a 15-day drinking water exposure in a slightly different mouse strain, C57Bl/6N. The study design examined the spleen and thymus weights, splenocyte and thymocyte numbers, and IgM response of the immune system to the immunological challenges as described above. The LOAEL was 3.75 mg/kg/day based on a significant decrease in IgM response, and the NOAEL was 1.88 mg/kg/day.

In one component of the Yang et al. study (2002b), the functional impact of changes in spleen and thymus were evaluated through the response of treated mice to HRBCs. The control mice responded to the HRBC exposure with an increased plaque-forming response; however, the PFOA-treated mice did not have an increased plaque-forming response when tested (Yang et al. 2002b). In addition, when blood from PFOA-treated mice was evaluated posttreatment, there was no increase in lymphocyte proliferation in response to the addition of Con-A and LPS to the test media. The control mice responded with the expected lymphocyte proliferation after the addition of Con-A and LPS antigens.

Loveless et al. (2008) looked at the IgM response to SRBC in male CD rats and CD-1 mice following a 29-day exposure to 0–30 mg PFOA/kg/day. The thymus and spleen cell counts and organ weights and the IgM titers were not altered by PFOA treatment in rats. In mice, however, thymus and spleen weights, thymus and spleen cell counts, and IgM titers were decreased at ≥ 10 mg PFOA/kg/day. CORT also was increased in mice at the same doses.

The data collected from the immunotoxicity studies support a MoA through which PFOA interferes with splenocyte and thymocyte precursor cells in the bone marrow as well as maturation of the cells once they have been transported to their respective organs. Examination of cell populations at different stages of development reveals lower numbers of the CD4⁺CD8⁻ cells formed in bone marrow as well as decreased populations of splenocyte and thymocyte cells at different stages of expressing the surface proteins that mark them as functional beta lymphocytes (thymus) or T-helper cells (spleen) (Son et al. 2009). Although the studies that measured the splenocyte and thymocyte populations were carried out at doses higher than the 3.75 mg/kg/day LOAEL observed by DeWitt et al. (2008), the fact that the IgM response to an antigenic material was decreased at that dose indicates an inability to produce antibodies at adequate levels when exposed to a challenge.

Loveless et al. (2008) hypothesized that the observed effects on serum lymphocytes could be the result of adrenocorticotropic steroids in a response to stress. A study by DeWitt et al. (2009) in which the immunological response of ADX mice treated with PFOA were compared to sham-operated controls did not support the Loveless et al. (2008) hypothesis.

Data from PPAR α -null mice suggest that rodents might be more susceptible to the immunosuppressive impacts of PFOA than humans. However, the fact that there were still effects on the thymus weight and cellularity even in the PPAR α -null mouse strain indicate the potential for an inadequate humoral response in exposed populations.

3.4.2 Synthesis and Evaluation of Carcinogenic Effects

Evidence of carcinogenic effects of PFOA in epidemiology studies is based primarily on studies of kidney and testicular cancer. These cancers have relatively high survival rates (e.g., 2005–2011 5-year survival rates 73% and 95%, respectively, for kidney and testicular cancer based on NCI Surveillance, Epidemiology and End Results data). Thus studies that

examine cancer incidence are particularly useful for these types of cancer. The high-exposure community studies also have the advantage, for testicular cancer, of including the age period of greatest risk, as the median age at diagnosis is 33 years. The two occupational cohorts in Minnesota and West Virginia (most recently updated in Raleigh et al. 2014 and Steenland and Woskie 2012) do not support an increased risk of these cancers, but each of these is limited by a small number of observed cases (six kidney cancer deaths, 16 incident kidney cancer cases, and five incident testicular cancer cases in Raleigh et al. 2014; and 12 kidney cancer deaths and 1 testicular cancer death in Steenland and Woskie 2012). Two studies involving members of the C8 Health Project showed a positive association between PFOA levels (mean at enrollment 0.024 µg/mL) and kidney and testicular cancers (Barry et al. 2013; Vieira et al. 2013); there is some overlap in the cases included in these studies. No associations were found in the general population between mean serum PFOA levels up to 0.0866 µg/mL and colorectal, breast, prostate, bladder, and liver cancer (Bonfeld-Jørgensen et al. 2014; Eriksen et al. 2009; Hardell et al. 2014; Innes et al. 2014); none of these studies examined kidney or testicular cancer.

Two animal carcinogenicity studies indicate that PFOA exposure can lead to liver adenomas (Biegel et al. 2001), Leydig cell adenomas (Biegel et al. 2001; Butenhoff et al. 2012), and PACTs (Biegel et al. 2001) in male Sprague-Dawley rats. Liver adenomas were observed in the Biegel et al. study (2001) at an incidence of 10/76 (13%) at 20 mg/kg/day. The incidence in the control group was 2/80 (3%). Although no liver adenomas were observed in Butenhoff et al. (2012), carcinomas were identified in the male controls, males in the low-dose group (2 mg/kg/day), and male and female rats in the high-dose group (20 mg/kg/day). The differences from control were not significant in either study, but the carcinoma incidence among the Butenhoff et al. (2012) high-dose males (10/50) was similar to that for the adenomas in the Biegel et al. study (2001) (10/76). Liver lesions were identified in the males and females at the 1- and 2-year sacrifices (Butenhoff et al. 2012). An increased incidence of diffuse hepatomegalocytosis and hepatocellular necrosis occurred at 20 mg/kg/day. At the 2-year sacrifice, hepatic cystoid degeneration (characterized by areas of multilocular microcysts in the liver parenchyma) was observed in 8, 14, and 56% in males of the control, 2-, and 20-mg/kg/day dose groups, respectively. Hyperplastic nodules in male livers were increased in the high-dose group (6% versus 0% in control rats).

Filgo et al. (2015) examined the livers of three strains of mice exposed only during gestation/lactation for tumors when they were sacrificed at 18 months. Liver tumors were found in each dose group, but tumor types varied and the data did not display any evidence of dose response. The animals were survivors from two different projects and the number per dose group was small. Thus, the data are not adequate for determining whether PFOA is a carcinogen in mice.

Testicular LCTs were identified in both the Butenhoff et al. (2012) and Biegel et al. (2001) studies. The tumor incidence was 0/50 (0%), 2/50 (4%), and 7/50 (14%) for the control, 2.0-, and 20-mg/kg/day dose groups, respectively (Butenhoff et al. 2012). The Biegel et al. study (2001) included one dose group (20 mg/kg/day); the tumor incidence was 8/76 (11%) compared to 0/80 (0%) in the control group. LCT incidence at 20 mg/kg/day was comparable between the two studies (11 and 14%).

PACTs were only observed in the Biegel et al. study (2001). The incidence was 8/76 (11%; 7 adenoma, 1 carcinoma) at 20 mg/kg/day while none were observed in the control animals. Although no PACTs were observed by Butenhoff et al. (2012), pancreatic acinar hyperplasia was observed at 2 and 20 mg/kg/day at incidences of 2/34 (6%) and 1/43 (2%), respectively, which

lacked dose response. Reexamination of the pancreatic lesions in Butenhoff et al. (2012) and Biegel et al. (2001) resulted in the conclusion that 20 mg/kg/day increased the incidence of proliferative acinar cell lesions in both studies. Some lesions in the Biegel et al. study (2001) had progressed to adenomas.

The initial findings from the Butenhoff et al. study (2012) were equivocal for mammary fibroadenomas in female rats. However, a reexamination of the tissues by a PWG found no statistically significant differences in the incidence of fibroadenomas or other neoplasms of the mammary gland between control and treated animals (Hardisty et al. 2010). The PWG used the diagnostic criteria and nomenclature of the Society of Toxicological Pathologists for the reexamination. Under those criteria, there was an increase in the number of tumors documented in the control group, especially fibroadenomas originally classified as lobular hyperplasia. The reclassification led to a loss of significance when the tumors in the treated animals were compared to tumors in the control animals.

Ovarian tubular hyperplasia and adenomas also were observed in female rats (Butenhoff et al. 2012). Mann and Frame (2004) reexamined the ovarian lesions using an updated nomenclature system, which resulted in some of the hyperplastic lesions being reclassified. The ovarian lesions originally described as tubular hyperplasia or tubular adenomas were regarded as gonadal stromal hyperplasia and/or adenomas. After the reclassification, there were no statistically significant increases in hyperplasia (total number), adenomas, or hyperplasia/adenoma combined in treated groups compared to controls.

Mutagenicity studies of PFOA using the *S. typhimurium* (Friere et al. 2008; Lawlor 1995, 1996) and *E. coli* (Lawlor 1995, 1996) system have resulted in negative results in the presence and absence of activation. One mutagenicity study (Lawlor 1995, 1996) in *S. typhimurium* gave a positive result, but it was not reproducible. Clastogenicity studies in CHO by Murli (1996b, 1996c) were positive with activation for chromosomal abnormalities and polyploidy and equivocal in the absence of activation. Micronucleus assays by Murli (1995, 1996d) were negative.

A significant increase in 8-OH-dG liver levels, a biomarker for oxidative stress, was observed at ≥ 10 mg PFOA/kg in the liver but not the kidney of Fischer 344 male rats by Takagi et al. (1991). Work with HepG2 cells by Hu and Hu (2009) suggested that PFOA could induce apoptosis by overwhelming the homeostasis of antioxidative systems, increasing ROS, impacting mitochondria, and changing expression of apoptosis gene regulators. Eriksen et al. (2010) observed a PFOA-induced increase in ROS production in HepG2 cells, but no PFOA-induced oxidative DNA damage or cytotoxicity.

3.4.3 Mode of Action and Implications in Cancer Assessment

The modes of toxicological/carcinogenic action of PFOA are not clearly understood. However, available data suggest that the induction of tumors is likely due to nongenotoxic mechanism involving membrane receptor activation, perturbations of the endocrine system, and/or the process of DNA replication and cell division. PFOA lacks the ability to react with and modify DNA, although its electrostatic properties would permit interaction with chromosomal histone proteins with a net positive surface charge.

Rat Liver Tumors. PPAR α agonism has been proposed as a potential MOA for the liver carcinomas and adenomas in rats following chronic PFOA exposure (Maloney and Waxman 1999; Klaunig et al. 2003, 2012). In the PPAR α agonism MOA, binding of PFOA to the PPAR α receptor results in increased peroxisome proliferation and cell replication. PPAR α is primarily expressed in the liver, but also is present in the kidney, intestines, heart, and brown adipose tissue (Hall et al. 2012).

Peroxisomes are single-membrane organelles found in a number of plant and animal cells that have the capacity to carry out beta oxidation of long-chain fatty acids and other substrates through hydrogen peroxide-generating pathways and without the generation of ATP (Goodrich and Sul 2000). Peroxisomes metabolize the long-chain fatty acids via both beta and omega oxidation pathways (Fielding 2000), but are unable to metabolize fatty acid chains of eight carbons or less (Garrett and Grisham 1999). The shorter chain fatty acids are exported to the cytosol and taken up by mitochondria for further degradation via beta oxidation with resultant production of acetyl-CoA and ATP.

When a chemical binds to and activates the PPAR α receptor, it forms a heterodimer with the retinoid-X receptor and binds to the peroxisome proliferator response element found in the promoter region of selected genes (Spector 2000). In addition to a variety of xenobiotic chemicals, there are a number of endogenous substances in animals and humans that can activate the PPAR α receptor, including unsaturated C18 fatty acids, metabolites of arachidonic acid, and the prostaglandin metabolite PGJ2 (Spector 2000). PPAR α activation is accompanied by upregulation of many genes associated with catabolism of fatty acid and cholesterol biosynthesis and lipid transport (Hall et al. 2012; Rosen et al. 2008a).

There are four key events in the PPAR α -agonist MOA for liver tumors (Klaunig et al. 2003, 2012) (see Figure 3-1). The first key event is activation of PPAR α . Increased palmitoyl-CoA oxidase activity is used in many studies as a biomarker for PPAR α activations. Other associated indicators are hepatocellular hypertrophy and increased liver weight. However, these indicators alone are not sufficient to establish a PPAR α MOA because they also are caused by chemicals that have no influence on PPAR α .

The primary data that demonstrate PFOA activation of the PPAR α receptor are those from Rosen et al. (2008a, 2008b) that examined the transcript profiles in the livers of wild-type and PPAR α -null mice dosed with 1, 3, and 10 mg/kg/day PFOA for up to 7 days. The data from the wild-type mice were compared to those from the known PPAR α gene activator Wyeth 14,643 and PPAR α -null mice. Based on the analysis of gene regulation, it was clear that PPAR α activation was required for a majority of the transcriptional changes observed in the mouse liver following PFOA or Wyeth 14,643 exposure. The data from this study demonstrate the ability of PFOA to act as a PPAR α agonist.

Multiple studies in both rats and mice provide evidence that PFOA induces peroxisome proliferation in the liver (Elcombe et al. 2010; Minata et al. 2010; Pastoor et al. 1987; Wolf et al. 2008b; Yang et al. 2001). PFOA also was found to activate mouse and human PPAR α using a transient transfection cell assay (Takacs and Abbott (2007). Maloney and Waxman (1999) also demonstrated that 5–10 μ mol PFOA (2 to 4 mg/L) activated mouse PPAR α using COS1 cells (kidney fibroblast-derived cells) transfected with a luciferase reporter gene.

Key Events in the Mode of Action for PPAR α -Agonist Induced Rodent Liver Tumors

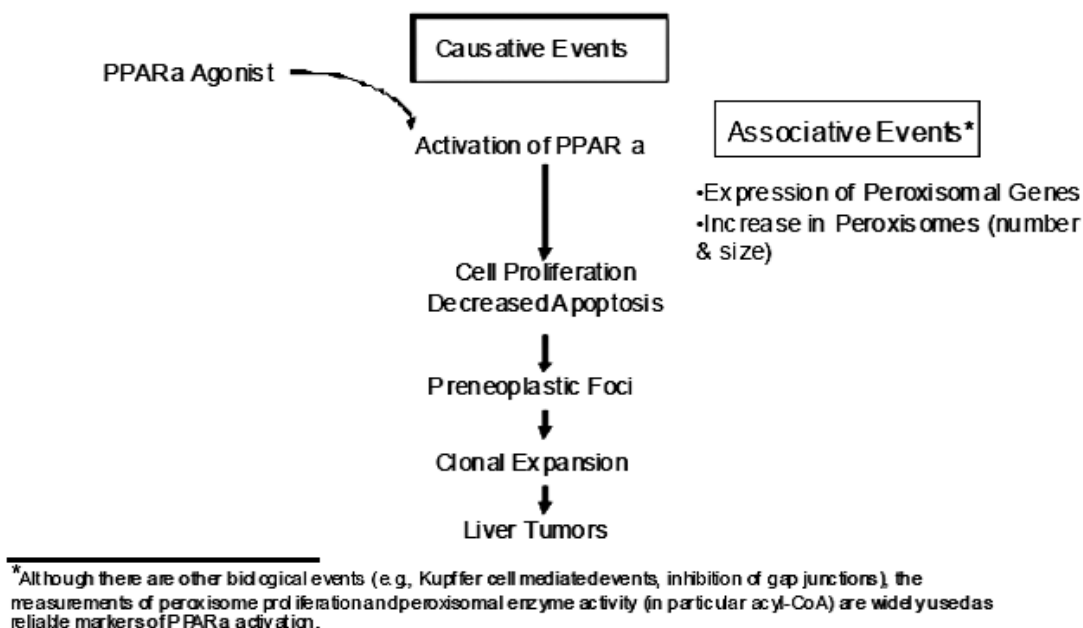

Source: USEPA 2005c

Figure 3-1. PPAR α Agonist MoA for Liver Tumors

In rodents, hepatic physical and biochemical changes observed after activation are highly correlated with liver tumors leading to the hypothesis that a > 3-fold increase in peroxisomes and > 1.5 fold increase in liver weights in short-term studies are sufficient to cause liver cancers in long-term studies (Hall et al. 2012). The temporal and dose-response relationship of measures of peroxisome proliferation, hepatocellular hypertrophy, liver weight, and liver histopathology were examined in male Sprague-Dawley rats following 4, 7, and 13 weeks of administration of dietary PFOA at doses ranging from 0–6.5 mg/kg/day (Perkins et al. 2004). There was no evidence of peroxisome proliferation, hepatocellular hypertrophy, or liver weight increases at 0.06 mg/kg/day. However, at 13 weeks, the 6.5-mg/kg/day dose had an increase in palmitoyl-CoA oxidase activity (an indicator for peroxisomes) that was 3.4 times greater than that for the pair-fed control. The absolute liver weight was 1.6 times greater than the pair-fed control. At the lower 1.94 mg/kg/day doses, the increases were 2.8 and 1.4 for the palmitoyl-CoA and liver weight, respectively

There are indications that PFOA also acts through PPAR α -independent mechanisms associated with CAR and PXR receptors. Martin et al. (2007) examined the genomic signature from PFOA-treated Sprague-Dawley rats (up to 5-day exposure) using microarray expression profiling, pathway analysis, and quantitative PCR. The animal responses were consistent with PPAR α agonism, but there was also evidence of PPAR γ agonism (downregulation of cholesterol synthesis) and activation of CAR- and PXR-related genes. CAR activation can lead to hepatocyte proliferation and hepatocarcinogenesis in animals. However, the human CAR receptor is relatively resistant to mitogenic effects and less likely to induce cancers through this mechanism (Hall et al. 2012). In rodents, the PXR receptor can interact with PPAR α in the coordination of

hepatocyte proliferation, but there are differences in the amino acid composition of the ligand binding domain of the mouse receptor and the human receptor (10% homology) (Hall et al. 2012). Accordingly, although the line of evidence is strongest for PPAR α activation as the initiator for the downstream events in the PFOA cancer MOA, there can be involvement from other membrane receptors other than PPAR α .

The second step in the PPAR α MoA calls for evidence for increased cell proliferation and decreased apoptosis. Few studies examined the occurrence of these events with PFOA. Son et al. (2008) saw evidence of decreased apoptosis in liver and kidney cells stained for caspase3 in 4-week-old male ICR mice treated for 21 days at a dose of about 20 mg/kg/day. However, Elcombe et al. (2010) failed to see a significant decrease in male Sprague-Dawley rats with a 28-day exposure to a diet containing 300 ppm (~20 mg/kg/day) PFOA (comparable to the high dose in both cancer studies). In wild-type 129S4/SvImJ mice, Minata et al. (2010) observed increased apoptosis in hepatocytes, arterial walls, and bile duct epithelium and in the bile duct epithelium of PPAR α -null mice at 10.8 and 21.6 mg/kg PFOA. Thus, the apoptosis data for PFOA are not consistently supportive of the key step in this proposed MoA (i.e., a decrease in apoptosis).

Using a BrdU labeling technique, Elcombe et al. (2010) observed significant increases in cell proliferation in male Sprague-Dawley rats after 1, 7, and 28 days of exposure to a 300-ppm PFOA dietary dose. The highest increase was observed after 7 days of treatment (a fivefold increase) and declined to a twofold increase after 28 days of dosing. The liver results from the Biegel et al. (2001) mechanistic study were negative for cell proliferation in male Sprague-Dawley rats exposed to the same dietary concentration (20 mg/kg/day) and sacrificed at 1, 3, 6, 9, 12, and 15 months. However, based on the Elcombe et al. (2010) observations, the timing of the interim sacrifice would have missed the peak of the proliferative response. The Butenhoff et al. study (2012) identified hyperplastic nodules in 3/50 high-dose males and 2/50 high-dose females at 20 mg/kg/day; 5/50 males and 1/50 females had hepatocellular carcinomas.

The study by Wolf et al. (2008a) looked at the labeling index in 129S1/SvImJ mice and PPAR α -null mice and found a difference in their dose response. In the wild-type mice, the labeling index was increased at all doses \geq 1 mg/kg/day; however, in PPAR α -null mice, the labeling index was increased only at the highest dose, 10 mg/kg/day.

There were no studies identified that focused specifically on preneoplastic foci and clonal expansion of altered cells after PPAR activation. Minata et al. (2010) observed a dose-dependent increase in eosinophilic cytoplasmic changes consistent with peroxisome proliferation in liver parenchyma, but found no focal necrosis at doses \leq 21.6 mg/kg/day in wild-type 129S4/SvImJ mice.

Klaunig et al. (2003, 2012) concluded that, based on the available data, PFOA-induced liver tumors in Sprague-Dawley rats can be attributed to a PPAR α MOA since there are data available addressing most of the key steps in this proposed MoA. However, some data gaps exist for key events and other mechanisms that might be involved. Overall, the tumor response observed in the available studies was not strong and did not demonstrate a dose-related response in males (3/49, 1/50, and 5/50 hepatocellular carcinomas in the control, 2-mg/kg/day, and 20-mg/kg/day dose groups, respectively) and a single carcinoma in females at the high dose. Biegel et al. (2001) did not identify any liver carcinomas (0/76) in males at their 20-mg/kg dose, but there were 10/76 males with adenomas. This is consistent with a hyperplastic tissue response rather than the loss of cell cycle control characteristic of cancer. The data from the Butenhoff et al. (2012) and

Biegel et al. (2001) studies suggest that PFOA is not a potent hepatic carcinogen based on the low tumor incidence and finding of hyperplastic nodules.

Leydig Cell Tumors (LCT). LCTs were observed in both the Butenhoff et al. (2012) and Biegel et al. (2001) studies. The LCT incidence was 0/49, 2/50, and 7/50 at doses of 0, 2, and 20 mg/kg/day, respectively, in Butenhoff et al. (2012) and 2/78 (pair-fed control) and 8/76 at 20 mg/kg/day in Biegel et al. (2001).

A large number of nongenotoxic compounds of diverse chemical structures have been reported to induce LCTs in rats, mice, or dogs. LCTs also occur in humans but are relatively rare at about 1–3% of human testicular tumors, which also are infrequent (1%) (Carpino et al. 2007). A workshop report (Clegg et al. 1997) on the MOA for LCT classified the chemicals that caused LCT in animal studies into seven MOA categories. The postulated MOAs support the following hormonal steps to the process:

1. A xenobiotic chemical inhibits the production of testosterone, leading to low serum levels.
2. Low serum testosterone levels signal the hypothalamus to produce gonadotropin releasing hormone (GnRH).
3. GnRH signals the pituitary to release LH.
4. LH signals the Leydig cells to produce testosterone.
5. LH causes Leydig cell proliferation.

Several of the available PFOA studies support an impact of PFOA on decreased testosterone production. Studies conducted by Cook and colleagues (Biegel et al. 1995; Cook et al. 1992; Liu et al. 1996) found that adult male rats administered PFOA by gavage for 14 days had decreased serum testosterone and increased serum estradiol levels (Cook et al. 1992). These endocrine changes correlated with its potency to induce LCTs (Biegel et al. 2001).

Subsequent experiments demonstrated that PFOA increased levels of estradiol by inducing cytochrome P450 CYP19 (aromatase). Aromatase converts androgens to estrogens, including the conversion of testosterone to estradiol. PFOA directly inhibits testosterone production when incubated with isolated Leydig cells and *ex vivo* studies demonstrate that this inhibition is reversible (Biegel et al. 1995). However, in the mechanistic bioassay by Biegel et al. (2001), serum testosterone and LH levels were not significantly altered at the levels of PFOA that resulted in LCTs (20 mg/kg/day).

This inhibition of testosterone biosynthesis can be mediated by PPAR α (Gazouli et al. 2002). Support for PPAR α -mediated inhibition of testosterone production is found in Li et al. (2011). Lower testosterone concentrations, reduced reproductive organ weights, and increased sperm abnormalities were found in PFOA-treated male PPAR α wild-type and humanized PPAR α mice but not in PPAR α -null mice. Similarly, disruption of testosterone biosynthesis by lowering the delivery of cholesterol into the mitochondria and decreasing the conversion of cholesterol to pregnenolone and androstandione in the testis was noted in wild-type and humanized PPAR α mice. These effects were not seen in PPAR α -null mice. Decreased serum testosterone was noted after oral exposure to PFOA in studies by Biegel et al. (1995, 2001) and Cook (1992).

The induction of LCTs by PFOA also can be attributed to a hormonal mechanism whereby PFOA either inhibits testosterone biosynthesis and/or lowers testosterone by increasing its conversion to estradiol through increased aromatase activity in the liver. Both of these mechanisms appear to be mediated by PPAR α . However, data are not currently sufficient to

demonstrate that the other key steps in the postulated MOA are present in PFOA-treated animals following exposures that lead to tumor formation. Studies are needed to demonstrate the increase of GnRH and LH in concert with the changes in aromatase and estradiol. There was also no indication of increased Leydig cell proliferation at the doses that caused adenomas in the Biegel et al. study (2001). Thus, additional research is needed to determine if the hormone testosterone-estradiol imbalance is a key factor in development of LCTs as a result of PFOA exposure.

Two studies involving members of the C8 Health Project showed a positive association between PFOA levels (mean at enrollment 0.024 µg/mL) and kidney and testicular cancers (Vieira et al. 2013; Barry et al. 2013). This contributed to the EPA conclusion that PFOA can be classified as having *suggestive evidence* for carcinogenicity.

Pancreatic Acinar Cell Tumors. The 2-year bioassay by Biegel (2001) identified PACTs in 7/6 rats receiving a 20-mg/kg dose for 2 years compared to 1/79 in the pair-fed controls. As with LCTs, the MOA for PACTs is not understood. These tumors are most commonly identified in rats, but do occur in other animal species (e.g., mice, hamsters) and in humans (Wisnoski et al. 2008). Males are more susceptible to pancreatic tumors than females. Two hypothetical MOAs have been proposed and are as follows (Klaunig et al. 2003, 2012; Obourn et al. 1997):

- There is a change in the bile acid flow or composition that leads to cholestasis, thereby causing an increase in CCK activating a feedback loop resulting in proliferation of the secretory pancreatic acinar cells. CCK is a peptide hormone that stimulates the digestion of fat and protein, causes the increased production of hepatic bile, and stimulates contraction of the gall bladder. An HFD, trypsin inhibition, and changes in bile composition are proposed initiators for this sequence of events.
- Increased levels of testosterone support the growth of acinar cell preneoplastic foci, leading to the development of carcinomas.

There is minimal information on the relationship of PFOA exposure to either of the proposed MOAs. Obourn et al. (1997) studied the impact of PFOA on CCK and trypsin using *in vitro* assays and found that PFOA was not an agonist for the CCKA receptor that activates CCK release. PFOA also had no inhibitory action on trypsin at levels 1,000 times greater (0.31 µg/mL) than the positive control.

The Obourn et al. study (1997) also looked at Wyeth 14,643, a peroxisome proliferator, in these same assays and found results similar to those for PFOA. When they conducted an *in vivo* study with 100 ppm Wyeth 14,643, they found a small but significant increase ($p < 0.05$) in bile flow per unit body weight, a decrease ($p < 0.05$) in bile flow per unit liver weight, and a small decrease ($p < 0.05$) in the total bile acid concentration following a 6-month dietary exposure.

There is the potential for PFOA to change the composition of bile because of its competition with bile acids for biliary transport. In mice, increased expression of MRP3 and MRP4 transporters (Maher et al. 2008) and decreased expression of OATPs (Cheng and Klaassen 2008) favor excretion of PFOA into the bile. Minata et al. (2010) found the levels of PFOA in bile from wild-type male mice to be considerably higher than those in PPAR α -null mice, suggesting a link to PPAR α . In the same study, male wild-type and PPAR α -null mice were orally dosed with ~0, 5.4, 10.8, and 21.6 mg/kg/day of PFOA for 4 weeks. Total bile acid was significantly increased at the highest dose in PPAR α -null mice suggesting that, in the presence of PFOA, activation of PPAR α increases PFOA excretion, a scenario that could possibly decrease the flow of bile acids competing for the same transporters. In the Butenhoff et al. study (2012), there was a lack of

PACT tumors but an increase in proliferative lesions of the acinar cells. One hypothesis offered for the difference in results was differences in the diets used in the two studies (Chang et al. 2014).

PFOA appears to suppress testosterone production through the induction of aromatase (Biegel et al. 1995; Cook et al. 1992; Liu et al. 1996) and to increase the estradiol. Accordingly, the second proposed MOA for PACTs does not appear to apply to PFOA.

The data on a PPAR α -linked MoA are strongest for the liver tumors. Some data also provide a link of PPAR α to the Leydig cell and PACT tumors observed in the rat 2-year bioassays. They are not as strong and identify a need for additional research justifying the suggestive evidence finding. However, when integrated with the metabolic inertness of PFOA in animals and humans, a linear response to dose is not likely. This is consistent with the tumor data. Thus a nonlinear MOA is likely and the remaining challenge is to identify the critical event in each MOA that leads to development of the tumors.

Other Potential Modes of Action. There are other potential MOAs that could apply to PFOA. They include interruption of intercellular communication, mitochondrial effects, and hormonal effects. None of these mechanisms are considered to be key steps in the MOAs discussed above.

GJIC, a process by which cells exchange ions, messages, and other small molecules, is important for normal growth, development, and differentiation as well as for maintenance of homeostasis in multicellular organisms. Because tumor formation requires loss of homeostasis and many tumor promoters inhibit GJIC, it has been hypothesized that GJIC might play a role in carcinogenesis (Trosko et al. 1998). PFOA has been demonstrated to inhibit GJIC in liver cells *in vitro* and *in vivo* (Upham et al. 1998, 2009). However, inhibition of GJIC is a widespread phenomenon, and the effect by PFOA was neither species- nor tissue-specific. In addition it was reversible. Thus, the significance of GJIC inhibition in regard to the mode of carcinogenic action of PFOA is unknown.

Several chemicals structurally related to PFOA have been shown to manifest their toxicity by interfering with mitochondria biogenesis and bioenergetics. Walters et al. (2009) found evidence supporting mitochondrial proliferation in Sprague-Dawley rats receiving 30 mg/kg/day of PFOA for 28 days as reflected in measurements of mitochondrial DNA, transcription factors, and other biomarkers for mitochondrial effects. Dietary PFOA also was demonstrated to uncouple oxidative phosphorylation in mitochondria of the liver from rats exposed via their diet (Keller et al. 1992). At high concentrations, PFOA caused a small increase in resting respiration rate and slight decreases in the membrane potential. The observed effects were attributed to a slight increase in nonselective permeability of the mitochondria membranes caused by PFOA's surface-active properties (Starkov and Wallace 2002). Quist et al. (2015) found evidence of mitochondrial proliferation in the liver of CD-1 mice pups from dams exposed to 1 mg/kg/day during gestation and lactation when tissues were examined using transmission electron microscopy at PND 21 and 91.

3.4.4 Weight of Evidence Evaluation for Carcinogenicity

The findings for cancer in humans provide support for an association between PFOA and kidney and testicular cancers; however, the number of independent studies examining each of these is limited. The support comes from high-exposure community studies examining cancer incidence and covering children and young adults (Barry et al. 2013; Vieira et al. 2013); there is

some overlap in the cases included in these studies. The two occupational cohorts in Minnesota and West Virginia (most recently updated in Raleigh et al. 2014 and Steenland and Woskie 2012) do not support an increased risk of kidney or testicular cancer, but are limited by a very small number of observed cases. None of the general population studies examined these cancers, but associations were not seen in the general population studies addressing colorectal, breast, prostate, bladder, and liver cancer, with mean serum PFOA levels up to 0.0866 µg/mL (Bonefeld-Jørgensen et al. 2014; Eriksen et al. 2009; Hardell et al. 2014; Innes et al. 2014).

The only chronic bioassays of PFOA were conducted in rats (Butenhoff et al. 2012; Biegel et al. 2001). The two studies support a positive finding for the ability of PFOA to be tumorigenic in one or more organs of male, but not female, rats. There are no carcinogenicity data from a second animal species. There are some data that provide support for the hypothesis that the PPAR α agonism MOA is wholly or partially linked to each of the observed tumor types. The data support a PPAR α MOA for the liver tumors and thus are indicative of lack of relevance to humans. PPAR α activation also could play a role in the other tumor types observed, but more data to support intermediate steps in the proposed MOAs are needed.

The mutagenicity data on PFOA are largely negative, although there is some evidence for clastogenicity in the presence of microsomal activation and at cytotoxic concentrations. Given the chemical and physical properties of PFOA—including the fact that it is not metabolized, binds to cellular proteins, and carries a net negative electrostatic surface charge—the clastogenic effects are likely the result of an indirect mechanism. PFOA has the potential to interfere with the process of DNA replication because of its protein binding properties and the fact that histone proteins, spermine and spermidine, carry a net positive surface charge. Involvement of ROS in the MOA as a result of PFOA alone is unlikely because of its metabolic stability. Conditions leading to ROS would be a function of metabolic responses perturbed by PFOA rather than PFOA alone. A compound that is not metabolized will not be able to covalently alter the structure of DNA or intercalate because of electrostatic repulsion between the aromatic base pi bond electrons with the partial negative charges on the PFOA fluoride atoms. Due to its protein binding properties, PFOA could have an impact on one or more of the proteins involved in the process of DNA replication or cell division (cytoskeletal proteins); however, no mechanistic studies were identified that examined the biochemical effects of PFOA on DNA replication or cell division. There are no data that support the clastogenic MOA.

Despite the limitations in the data for the LCTs and PACTs, under the *U.S. EPA Guidelines for Carcinogen Risk Assessment (USEPA 2005a)* there is suggestive evidence of carcinogenic potential of PFOA in humans.

3.4.5 Potentially Sensitive Populations

Human biomonitoring studies do not suggest major differences between serum PFOA levels in males and females. However, the worker populations that are those most likely to demonstrate such differences because of their higher exposures were predominantly male.

Some animal species have gender differences that affect toxicity of PFOA. Sexually mature female rats excreted almost all of a 10-mg/kg dose of PFOA within 48 hours compared to only 19% excreted by male rats. Male hamsters excrete PFOA faster than female hamsters, and female rabbits excrete PFOA slightly faster than male rabbits. Male and female mice excrete PFOA at approximately the same rate (Hundley et al. 2006). Studies of the transporters involved in the toxicokinetics of PFOA demonstrate that they are differentially impacted by the presence

of male and female sex hormones influencing tissue persistence (Cheng et al. 2006; Kudo et al. 2002). As studied in rats (Kudo et al. 2002), the male sex hormones increased half-life (decreased excretion) of PFOA while the female hormones were associated with shorter half-lives (increased excretion). The gender differences in mice are not as pronounced as those in rats. Work by Cheng et al. (2006) and Cheng and Klaassen (2009) demonstrated that these hormones impact transporters in the liver and kidney.

In studies in which both male and female rats were used, the males were more sensitive to toxicity than were the female rats (Butenhoff et al. 2004a). Mice displayed similar sensitivities following PFOA exposure (Kennedy 1987). In the monkey studies, the number of animals per gender per dose group was too small to reveal a difference related to gender.

Unfortunately, much work remains to be done to determine whether the gender difference seen in rats is relevant to humans. Similarities are possible because the long half-life in humans suggests that they might be more like the male rat than the female rat. There is a broad range of half-lives in human epidemiology studies, suggesting a variability in human transport and binding capabilities resulting from genetic variations in transporter structures and, consequently, in function. Genetic variation in human OATs and OATPs has been identified as described in a review by Zair et al. (2008).

Neonates, Infants, and Fetuses

The developing fetus might be sensitive to effects of PFOA. The observed effects on birth weight in animals are supported by evidence of an association between PFOA and low birth weight in humans (Johnson et al. 2014). There is some uncertainty related to the interpretation of the small change in birth weight observed in humans. Specifically, it has been suggested that low GFR also can impact birth weight (Morken et al. 2014). Verner et al (2015) conducted a meta-analysis based on PBPK simulations and found that, in individuals with low GFR, there are increased levels of serum PFOA as well as lower birth weights. Thus, while there is some uncertainty in the interpretation of the observed association between PFOA and low GFR and birth weight given the available information, the data indicate that PFOA exposure does impact birth weight in the general population. In humans with low GFR (which includes females with pregnancy-induced hypertension or preeclampsia) who also are exposed to PFOA, the effect on body weight is likely due to a combination of both.

Several animal studies have examined potential MoAs for developmental effects following prenatal exposure to PFOA. PFOA exposure during development in rats and mice resulted in increased resorptions (mouse), increased fetal skeletal variation (rat, mouse), decreased neonatal survival (rat, mouse), decreased postnatal body weight (mouse), delayed eye opening and body hair growth (mouse), delayed vaginal opening (mouse), accelerated preputial separation (mouse), and delayed mammary gland development (mouse dam and offspring) (Abbott et al. 2007; Butenhoff et al. 2004a; Lau et al. 2006; Macon et al. 2011; Tucker et al. 2015; White et al. 2007, 2009, 2011; Wolf et al. 2007). Other long-term effects observed in the surviving offspring included increased body weight gain, serum leptin, and serum insulin levels along with changes in adipose tissue (Hines et al. 2009). The MOAs for these developmental effects are unknown, but several potential MoAs have been investigated.

Wolf et al. (2007) restricted mouse prenatal PFOA exposures to 3–11-day periods during gestation to determine if PFOA was affecting a certain stage of organogenesis resulting in the observed developmental effects. Decreased postnatal survival was observed at the highest dose

used (20 mg/kg/day). Eye opening and body hair growth were delayed in offspring exposed for the longest periods of time (GD 7–17 and GD 10–17) and might have been the result of a higher cumulative dose or greater sensitivity during early gestation. A cross-fostering paradigm was used to determine if the developmental effects were the result of gestational exposure, lactational exposure, or a combination of both. Postnatal survival was decreased in offspring exposed through gestation and lactation (5 mg/kg/day). Eye opening and body hair growth were delayed and body weight was reduced in offspring exposed during gestation (5 mg/kg/day), and gestation and lactation (3 and 5 mg/kg/day). No developmental delays in eye opening and body hair growth were observed in offspring exposed via lactation only, indicating that, for these developmental endpoints, PFOA alters growth regulation in the developing fetus that persists as growth continues postnatally.

Both gestational and lactational exposures contribute to the impact of PFOA on body weight during early life as illustrated by cross-fostering control unexposed female pups with those dosed with PFOA. Three cross-fostering combinations were evaluated by White et al. (2009): control pups nursed by exposed dams, exposed pups nursed by control dams, and exposed pups nursed by exposed dams. Two doses were evaluated: 3 and 5 mg/kg/day, but the body weight data was only provided for the 5-mg/kg/day dose group for PND 1–10. PFOA exposures significantly reduced pup body weights and increased liver weights. The body weight deficits compared to control were greatest for the gestation and lactation exposure combination and lowest for the lactation-only group.

Abbott et al. (2007) examined activation of PPAR α as a factor in the developmental toxicity of PFOA. Wild-type and PPAR α -null mice experienced full litter resorptions following gestational (GD 1–17) PFOA exposure (≥ 5 mg/kg/day), indicating that the mechanism of PFOA-induced resorptions was independent of PPAR α expression. These resorptions could be due to insufficient trophoblast cell type differentiation and/or increased trophoblast cell necrosis (Suh et al. 2011). Postnatal survival was significantly decreased in wild-type offspring but not in PPAR α -null offspring, indicating that PPAR α expression was required for postnatal lethality (Abbott et al. 2007). Eye opening was significantly delayed in wild-type offspring, but not in PPAR α -null offspring, although a trend was observed in those offspring for later eye opening. The results indicated that PPAR α expression was important for eye opening, but other PPAR α -independent factors also might play a role in its mechanism. Takacs and Abbott (2007) showed that PFOA can activate mouse PPAR β/δ , which is expressed in developing tissue, and suggested that inappropriate activation of PPAR β/δ could cause adverse effects. Further research needs to be conducted to fully elucidate the mechanism.

Mouse mammary gland development was another endpoint examined in prenatally PFOA-exposed offspring. White et al. (2007) found that dams dosed with 5 mg PFOA/kg/day on GD 1–17 and GD 8–17 had significantly delayed mammary gland development (full of alveoli, visible adipose tissue, not well differentiated) at PND 10, which is at the peak of lactation in rodents. The delayed dam mammary gland development could play a role in the observed reduced offspring body weight gain if the quantity or quality of the milk is altered by PFOA (Abbott et al. 2007; Lau et al. 2006; White et al. 2007; Wolf et al. 2007).

Restricted gestational exposure and cross-fostering studies showed that delayed offspring mammary gland development observed PND 1–63 occurred regardless of exposure duration or timing (gestation versus lactation exposure; maternal dose of 1 mg/kg/day). The developmental delays persisted even as the internal PFOA dose decreased (Macon et al. 2011; White et al. 2007, 2009, 2011). More studies need to be conducted to elucidate the MOA for dam and offspring

mammary gland effects and its potential functional consequences for lactating humans. White et al. (2011) conducted a multigeneration study of the effects of PFOA on mammary gland development and found no dose-related effects on the pup body weights nourished by dams with lower mammary gland scores than the controls. Tucker et al. (2015) demonstrated that a dose-response for developmental mammary gland effects varies by more than an order of magnitude, depending on the strain of mouse studied. CD-1 mice are more sensitive than C57BL/6 mice (Tucker et al. 2015).

Mammary gland development also was affected by peripubertal exposure to PFOA (C. Yang et al. 2009, Y. Zhao et al. 2010). Low doses (5 mg/kg/day) of PFOA from 3 to 7 weeks of age caused accelerated mammary gland development in C57BL/6 mice, but delayed mammary gland development in BALB/c mice, suggesting strain-related differences.

Experiments examining the mechanism for accelerated mammary gland development showed that PFOA promotes steroid hormone production in the ovaries and increases the levels of several mammary gland growth factors in C57BL/6 wild-type and PPAR α -null mice. The mechanism for delayed mammary gland development following a peripubertal PFOA exposure needs to be examined.

Hines et al. (2009) found that low doses of PFOA given during gestation to CD-1 mice resulted in significant weight gain and increased serum insulin and leptin levels of the offspring in mid-life. The increased leptin levels, as well other hormone perturbations, might place PFOA into the environmental endocrine disruptor obesogen category similar to diethylstilbestrol (Newbold et al. 2007). However, in a study by Quist et al. (2015) using the mature animals from the Hines et al. study (2009), there was no dose-related impact on serum leptin in CD-1 pups gestationally exposed across a dose range of 0–1 mg/kg/day when examined on PND 91, except in the group given an HFD and not fasted before serum collection. For those animals, there was a dose-related decrease in leptin. Other mice on an HFD that were fasted for 4 hours before serum collection in the same study lacked a dose-related leptin response. In humans, increased leptin levels are associated with increased body fat and suggestive of a leptin-resistance MOA for being overweight (Considine et al. 1996). A similar relationship might occur in prenatally PFOA-exposed mice; however, the Quist et al. study (2015) suggests that the fat content of the diet and the time of serum collection are important variables that need to be considered. Studies determining MOAs need to be conducted to determine relevance of the mammary gland effects to animal and human health.

Diet might influence the risk associated with PFOA exposures. Animal studies demonstrate an increased risk for liver steatosis in animals on an HFD (Quist et al. 2015; Tan et al. 2013) and possibly for insulin resistance (Hines et al. 2009). The epidemiology data are not supportive of a correlation with insulin resistance, but the observations of elevated serum triglycerides, especially among a highly exposed population, could be viewed as a risk factor for steatosis. Most of the epidemiology studies did not evaluate dietary factors as part of the study design for either birth weight or serum lipids (e.g., cholesterol, triglycerides, LDL).

4 DOSE-RESPONSE ASSESSMENT

4.1 Dose-Response for Noncancer Effects

An RfD or reference concentration (RfC) is used as a benchmark for the prevention of long-term toxic effects other than carcinogenicity. RfD/RfC determination assumes that thresholds exist for toxic effects, such as cellular necrosis, significant body or organ weight changes, blood disorders, and so forth. The RfD is expressed in terms of mg/kg/day and the RfC is expressed in milligrams per cubic meter (mg/m³). The RfD and RfC are estimates (with uncertainties spanning perhaps an order of magnitude) of the daily exposure to the human population (including sensitive subgroups) that is likely to be without an appreciable risk of deleterious effects during a lifetime.

4.1.1 RfD Determination

The derivation of the RfD for PFOA presented a number of challenges due to the toxicokinetic complexity of PFOA, variability in half-life between species, and metabolic inertness of PFOA in living organisms. The toxicokinetic features of PFOA lead to differences in half-lives across species and in the case of rats, and possibly humans, differences between genders. Toxicokinetics also influence intraindividual and lifestage variability in response to dose. Additionally there were inconsistencies across the epidemiology studies and the effects observed in animal studies, and a number of animal studies lacked a NOAEL. Each of these factors highlights the importance of having measures of internal dose for quantification of an RfD and supports the utilization of a PK model as a component of the dose-response assessment.

Human Data. Key studies examined occupational and residential populations at or near large-scale PFOA production plants in the United States in an attempt to determine the relationship between serum PFOA concentration and various health outcomes suggested by the standard animal toxicological database. Health outcomes assessed include blood lipid and clinical chemistry profiles, reproductive parameters, thyroid effects, diabetes, immune function, birth and fetal and developmental growth measures, and cancer.

Epidemiology studies examined workers at PFOA production plants, a high-exposure community population near a production plant in the United States (i.e., the C8 cohort), and members of the general population in the United States, Europe, and Asia. These studies examined the relationship between serum PFOA concentration (or other measures of PFOA exposure) and various health outcomes. Exposures in the highly-exposed C8 community are based on the concentrations in contaminated drinking water and serum measures. Exposures among the general population typically included multiple PFAS as indicated by serum measurements. The correlation among these compounds is often moderately strong (e.g., Spearman $r > 0.6$ for PFOA and PFOS in the general population). Mean serum levels among the occupational cohorts ranged approximately 1–4 µg/mL and in the C8 cohort they ranged 0.01–0.10 µg/mL. Geometric mean serum values for the NHANES general population (\geq age 12; 2003–2008) were 0.0045 µg/mL for males and 0.0036 µg/mL for females (Jain 2014).

These studies have generally found positive associations between serum PFOA concentration and TC (i.e., increasing lipid level with increasing PFOA) in the PFOA-exposed workers at mean serum levels 0.4 to >12 µg/mL and the high-exposure community at mean serum about 0.08 µg/mL; similar patterns are seen with LDLs but not with HDLs. These associations also

were seen in most of the general population studies (mean serum 0.002–0.007 µg/mL), but similar results were seen with PFOS and the studies did not adjust for these correlations. Associations between PFOA exposure and elevations in serum levels of ALT and GGT, were consistently observed in occupational cohorts, the high-exposure community, and the U.S. general population at serum PFOA concentrations also associated with increased TC. The associations are not large in magnitude, but they indicate the potential to affect liver function.

Thyroid disease incidence was associated with PFOA in women and girls in the high-exposure C8 study population and in women with background exposure at mean serum concentrations of 0.026–0.123 µg/mL. Changes in thyroid hormones were not consistently associated with PFOA concentration.

Associations between PFOA exposure and risk of infectious diseases (as a marker of immune suppression) have not been found, but a decreased response to vaccines in relation to PFOA exposure was reported in studies in adults in the high-exposure community population (median 0.032 µg/mL) and in studies in children in the general population (mean 0.004 µg/mL). In the latter studies, it is difficult to distinguish associations with PFOA from those of other correlated PFAAs. Increased risk of ulcerative colitis was reported in the high-exposure community study and in a study limited to workers in that population.

Studies in the high-exposure community reported an association between serum PFOA at approximately 0.01–0.02 µg/mL and risk of pregnancy-related hypertension or preeclampsia. This outcome has not been examined in other populations. An inverse association between maternal PFOA (measured during the second or third trimester) or cord blood PFOA concentrations and birth weight was seen in several studies, but the magnitude was small. It has also been suggested that low GFR can impact birth weight (Morken et al. 2014). Verner et al. (2015) conducted a meta-analysis based on PBPK simulations and found that some of the association reported between PFOA and birth weight could be partially attributable to low GFR. However, the study authors demonstrated that in individuals with low GFR there also are increased levels of serum PFOA. Thus, while there is some uncertainty in the interpretation of the observed association between PFOA and low GFR and birth weight given the available information, the data indicate that PFOA exposure does impact birth weight in the general population.

The epidemiology studies have not found associations between PFOA and diabetes, neurodevelopmental effects, or preterm birth and other complications of pregnancy. Developmental outcomes including delayed puberty onset in girls has been reported; however, in the two studies examining prenatal PFOA exposure in relation to menarche, conflicting results were found (i.e., no association or a possible indication of an earlier menarche seen with higher maternal PFOA levels in one study and a later menarche seen with higher maternal PFOA levels in the other study).

Animal Data—Long Term Studies. Some of the effects in animal studies are associated with activation of the PPAR α receptor leading to peroxisome proliferation. These include increased liver weight; decreases in serum triglycerides, cholesterol, and lipoproteins; and increases in ALT, AST, or both. However, although the mechanisms for other effects, such as decreased body weight, immunological effects, and developmental delays are unknown, they might be relevant to human health risk assessment.

As an initial step in the dose-response assessment, EPA identified a suite of animal studies with NOAELs, LOAELs, or both that identified the studies as candidates for development of a chronic RfD. These studies are listed in Table 4-1. The candidate studies were selected based on their NOAEL, LOAEL, or both; a duration of ≥ 7 weeks; use of a control; and two or more doses. Table 4-1 does not include the data from human epidemiology studies because, although they include information on serum levels, they do not identify exposure sources or external doses.

Table 4-1. NOAEL/LOAEL Data for Oral Subchronic and Chronic Studies of PFOA

Species	Study Duration	NOAEL mg/kg/day	LOAEL mg/kg/day	Critical Effects (s)	Reference
Monkey Male	90 days	none	3	↑ relative pituitary weight	Goldenthal 1978
Monkey Female	90 days	3	10	↓ absolute and relative heart weight	Goldenthal 1978
Monkey Male	26 weeks	none	3	↑ absolute liver weight (hepatocellular hypertrophy) and mean liver-to-body weight percentages	Butenhoff et al. 2002
Rat Male	13 weeks	0.64	1.94	↑ absolute and relative liver weight with hepatocellular hypertrophy accompanied by a slight, but not significant, increase in hepatic coagulative necrosis	Perkins et al. 2004
Rat Male F0 generation	84 days	none	1	↑ absolute and relative liver and kidney weight accompanied by ↓ body weight	Butenhoff et al. 2004a; York et al. 2010
Rat Male F1 generation	16 weeks	none	1	↓ body weights and weight gains; ↑ absolute and relative liver weights, liver hypertrophy; ↑ absolute and relative kidney weights	Butenhoff et al. 2004a; York et al. 2010
Rat Female F0 generation	127 days	30	none	No significant effects observed	Butenhoff et al. 2004a; York et al. 2010
Rat Female F1 generation	10 weeks	10	30	Delay in sexual maturity, ↓ body weight and weight gain	Butenhoff et al. 2004a; York et al. 2010
Rat Male and Female	2 years	1.3 (m) 1.6 (f)	14.2 (m) 16.1 (f)	M: ↓ body weight gain; histopathology lesions in liver, testes, and lungs. F: ↓ body weight gain	Butenhoff et al. 2012

When examining the effects associated with the LOAELs summarized in Table 4-1, changes in relative liver weight, absolute liver weight, or both appear to be a common denominator for monkeys and rats (Butenhoff et al. 2002, 2004a; Perkins et al. 2004) with or without other hepatic indicators of adversity. Serum PFOA levels, where available, associated with increased liver weight were 81 and 41 $\mu\text{g/mL}$ for the male monkey and rat, respectively. However, the increases in liver weight and hypertrophy are effects associated with activation of cellular PPAR α receptors, making it difficult to determine whether this change is totally a reflection of the PPAR α activation or PFOA toxicity and meet the Hall et al. (2012) criteria for establishing adversity for a PPAR α -activating chemical. Studies in PPAR α null mice and animals with a

human PPAR α receptor (Li et al. 2011; Minata et al. 2010; Nakamura et al. 2009; Wolf et al. 2008b), along with studies of hepatic gene activation by PFOA (Albrecht et al. 2013; Bjork and Wallace 2009; Nakamura et al. 2009; Rosen et al. 2008a, 2008b), suggest that the increase in liver weight is at least partially due to cellular impacts that are not controlled by PPAR α receptors. However, it remains difficult to separate the impact of PPAR α activation from the direct effects of PFOA in the candidate studies.

According to Hall et al. (2012), increases in liver weight can be considered adverse when accompanied by cellular necrosis, inflammation, fibrosis of the liver, and/or macrovesicular steatosis. There was some evidence of hepatic necrosis in the studies of Perkins et al. (2004) and in the male F1 generation adult rats from the Butenhoff et al. study (2004a), but the incidences were not statistically significant or described in detail. To the extent that adverse lesions reflect sensitivity in the animals impacted, they are used in the assessment to reflect that the liver hypertrophy and increased liver weight are adverse in individual animals where they are accompanied by necrosis.

Body weight effects were seen in several studies (Butenhoff et al. 2004a, 2012) and are a more toxicologically-relevant endpoint, especially in the cases where they were not accompanied by decreased food intake and when found in neonates (Butenhoff et al. 2004a). There were developmental delays for males and females in the two-generation study published by Butenhoff et al. (2004a). Testicular effects were observed by Butenhoff et al. (2012) and in the chronic one-dose study by Biegel et al. (2001). There was evidence of increased kidney weight in male F1 Sprague-Dawley rats (Butenhoff et al. 2004a) confounded by decreases in body weight at higher doses, but at lower doses the kidney weight effect is likely a reflection of tissue adaptation as a result of the requirement for upregulation of tubular transporters to facilitate urinary excretion using transporters developed for excretion of endogenous and dietary substrates rather than PFOA.

Four of the longer term studies in Table 4-1 lack a NOAEL and have LOAELs that range 1–3 mg/kg/day. The NOAELs for the remaining 7 studies range from 0.64 (male rats) to 30 mg/kg/day (female rats). Male monkeys and rats appear to respond at doses that are lower than their female counterparts. No long-term studies in mice were identified. Since NOAELs and LOAELs are to some extent the product of concentration or dose level selection, examination of the dose information in Table 4-1 suggests that several of the data sets that have serum data to inform modeling of internal doses have the potential to be co-critical in the dose-response evaluation.

Animal Data—Short Term Studies. A number of studies identified adverse effects following low dose exposures over durations of 7 to 38 days. The studies fall into two clusters, those evaluating developmental or reproductive effects and those with a focus on immunological effects. The critical shorter-term studies in rats and mice are summarized in Table 4-2. Although the exposure duration is shorter in developmental studies than the two-generation study, the developmental studies are important in quantification of dose-response because the exposures occur during critical windows of development and predicate effects that can occur later in life.

Table 4-2. Shorter-term and Developmental Oral Exposure Studies

Species	Study Duration	NOAEL (mg/kg/day)	LOAEL (mg/kg/day)	Critical Effect(s)	Reference
Rat					
Male	29 days	1	10	Increased absolute and relative liver weight, focal liver necrosis	Loveless et al. 2008
Male	14 days	0.2	2	↑ liver weight, ↑ serum estradiol and hepatic aromatase	Liu et al. 1996
Mouse					
Female offspring	17 days	none	1	Delayed mammary gland development in dams during lactation	White et al. 2011
Male & Female	38 days	1	5	↑ Ito cell hypertrophy at 18 months. Dosing occurred during gestation and lactation only.	Filgo et al. 2015
Female	38 days	0.01	0.03	↑ TC at PND 91 for fasted and nonfasted animals receiving a HFD but not those receiving the standard fat content control diet. Exposure occurred only during gestation and lactation.	Quist et al. 2015
Male	29 days	0.3	1	↑ absolute and relative liver weight, ↓ relative spleen weight, moderate-severe liver hypertrophy with single cell and focal necrosis	Loveless et al. 2008
Male	28 days	none	5	Significantly ↓ fertility based on pregnant females per male mouse, and ↓ pup birth weight.	Lu et al. 2015
Female	17 (pups) /18 (dams) days	none	1	↑ absolute maternal liver weight, ↓ ossification (calvarin, enlarged fontanel), accelerated onset of puberty in male offspring.	Lau et al. 2006
Female	17 days GDs 1–17	none	3	↑ absolute and relative maternal liver weight, delayed offspring eye opening and body hair growth, ↑ offspring relative liver weight, ↓ offspring body weight, delayed mammary gland development (female offspring).	White et al. 2009; Wolf et al. 2007
Female CD1	17 days GDs 1–17	none	0.3	Delayed mammary gland development	Macon et al. 2011
Female CD-1	17 days	none	0.01	Delayed mammary gland development at PND 56. Exposure occurred only during gestation.	Tucker et al. 2015
Female C57BL6	17 days	0.1	0.3	Delayed mammary gland development at PND 61. Exposure occurred only during gestation.	Tucker et al. 2015
Female	15 days	1.88	3.75	↓ IgM (1 day post-dose), increased IgG (15 days post-dose), ↓ absolute and relative spleen weight (1 day post-dose)	DeWitt et al. 2008

Species	Study Duration	NOAEL (mg/kg/day)	LOAEL (mg/kg/day)	Critical Effect(s)	Reference
Male	15 days	7.5	30	↓ sheep red blood cell IgM response in PPAR null mice indicate the response not completely PPAR dependent	DeWitt et al. 2015
Male	14 days	2.5	5	↓ sperm count, changes in testicular morphology, evidence of ↑ free radical oxidation	Liu et al. 2015
Male	14 days	0.2	2	↑ liver weight, serum estradiol and hepatic aromatase activity	Liu et al. 2015
Female	11 days GDs 7–17	none	5	↑ maternal and pup relative liver weight, delayed offspring eye opening and hair growth, ↓ male offspring body weight, delayed mammary gland development (female offspring)	White et al. 2009; Wolf et al. 2007
Female CD 1	8 days GDs 10–17	none	0.01	Delayed mammary gland development on PND 21 (female offspring)	Macon et al. 2011
Female CD 1	17 days GDs 1–17	none	0.3	Delayed mammary gland development on PND 14 (female offspring)	Macon et al. 2011

All but two of the short term studies used mice as the target species. Mice differ from rats in that the toxicokinetics of the males and females are similar. The half-life of PFOA in male rats is much longer than that in females, favoring higher serum levels in males after equivalent exposures. The difference in the excretion kinetics is a consequence of differences in renal transporters between male and female rats that appear to be under hormonal control. Several of the short term studies include serum data to support PK modeling of internal dose-response (DeWitt et al. 2008; Lau et al. 2006; Macon et al. 2011).

As was the case with the longer-term studies, increased liver weight was a common effect among the shorter-term studies. Increases in absolute or relative liver weights were reported in six of the studies that provided dose-response data from short term exposures (Lau et al. 2006; Liu et al. 1996, 2005; Loveless et al. 2008; White et al. 2009; Wolf et al. 2007) (Table 4-2). In some of the remaining studies, liver weight was not monitored as a variable. The Loveless et al. study (2008) identified significant focal liver necrosis in rats at the 10 mg/kg/day LOAEL, and both single cell and focal liver necrosis in mice at a LOAEL of 1 mg/kg/day. This might indicate that mice are more susceptible to necrosis than rats. Hepatic necrosis was reported in the longer duration Perkins et al. study (2004) of male rats and in the male F1 generation adult rats from the Butenhoff et al. study (2004a), but hepatic necrosis was present in few animals and not evaluated for statistical significance.

The co-occurring effects at the LOAEL were effects on spleen, thymus, liver, and/or developmental endpoints. Four of the studies involved exposures that occurred only during gestation and lactation and resulted in effects that were observed in the mature offspring. The hepatic and serum cholesterol effects in Quist et al. (2015) at PND 91 at a LOAEL of 0.03 mg/kg/day were present only in animals with elevated intakes of dietary fat. In adult animals with the same gestation/lactation only exposures, Filgo et al. (2015) identified a LOAEL of 5 mg/kg/day for accumulation of fat deposits in the liver Ito cells (steatosis). The study did not

provide information on the intakes of dietary lipid that could be compared with the data from Quist et al. (2015) to determine whether the effects were correlated with postnatal dietary fats or from the exposure during gestation and lactation.

A NOAEL of 2.5 mg/kg/day and a LOAEL of 5 mg/kg/day was reported for sperm counts and testicular morphology after a 14-day exposure by Liu et al. (2015). No impact on male fertility was observed in Sprague-Dawley rats in the two-generation Butenhoff et al. study (2004a), in contrast to the Lu et al. study (2015) where male fertility was decreased in mice at a dose of 5 mg/kg/day for 28 days. A 14-day exposure to 2 mg/kg/day (Liu et al. 2015) led to significantly increased serum estradiol and increased hepatic aromatase activity.

The developmental impacts of PFOA exposure ranged from delayed mammary gland development in pups (Albrecht et al. 2013; Macon et al. 2011; Tucker et al. 2015; White et al. 2009, 2011; Wolf et al. 2007) to delays in attaining developmental milestones such as ossification, eye opening, and hair growth (Lau et al. 2006; Wolf et al. 2007). The LOAEL for developmental effects on mammary glands in female offspring from dams given 0.01 mg/kg/day for 8 days from Macon et al. (2011) is of unknown biological significance. In the same study, no effects on offspring body weight were found at maternal doses up to 3 mg/kg/day for 17 days (Macon et al. 2011). Data from White et al. (2011) showed no significant effects on body weight gain in pups nursing from dams treated with 1 mg/kg/day despite these dams having less fully-developed mammary glands compared to controls. Similarly, no differences in response to lactational challenge were seen in PFOA-exposed dams with morphologically delayed mammary gland development (White et al. 2011).

The studies that looked at the delays in other developmental milestones including eye opening, hair growth, and bone ossification all lacked a NOAEL. In Lau et al. (2006), the LOAEL was 1 mg/kg/day for reduced ossification of the proximal phalanges (forelimb and hindlimb). In the Wolf et al. (2007) study, delays in eye opening and hair growth occurred at a LOAEL of 5 mg/kg/day for gestational exposures of both 1–17 days and 7–17 days. Attainment of sexual maturity in males from the Lau et al. study (2006), rather than being delayed, was accelerated, at the LOAEL of 1 mg/kg/day.

The LOAEL for the mammary gland developmental effects in female offspring from dams given 0.01 mg/kg/day for 8 days from Macon et al. (2011). In the same study, no effects on offspring body weight were found at maternal doses up to 3 mg/kg/day for 17 days (Macon et al. 2011). Data from White et al. (2011) showed no significant effects on body weight gain in pups nursing from dams treated with 1 mg/kg/day despite these dams having less fully-developed mammary glands compared to controls. Similarly, no differences in response to lactational challenge were seen in PFOA-exposed dams with morphologically-delayed mammary gland development (White et al. 2011). Given that milk production was sufficient to nourish growth in exposed pups, there is uncertainty related to the functional impact of this endpoint and thus it was not considered quantitatively.

A NOAEL of 2.5 mg/kg/day and a LOAEL of 5 mg/kg/day were reported for sperm counts and testicular morphology after a 14-day exposure by Liu et al. (2015). No impact on male fertility was observed in Sprague-Dawley rats in the two-generation Butenhoff et al. study (2004a) in contrast to the Lu et al. study (2015) where male fertility was decreased in mice at a dose of 5 mg/kg/day for 28 days. A 14-day exposure to 2 mg/kg/day (Liu et al. 2015) lead to significantly-increased serum estradiol and increased hepatic aromatase activity.

The studies by DeWitt et al. (2008, 2015) demonstrate effects of PFOA on spleen and thymus weights and the immunoglobulin response to SRBC or dinitrophenyl ficol in wild-type and PPAR α null mice. The DeWitt et al. (2015) data indicate that some but not all of the response is related to PPAR α activation. As supported by the epidemiology data, suppression of the immune system response to a challenge because of PFOA exposure is an area of concern for humans as well as animal species.

Six of the twelve studies lacked a NOAEL. For those studies with a NOAEL, the value ranged 0.01–7.5 mg/kg/day, while the LOAELs ranged 0.01–30 mg/kg/day. The range of values across studies is narrow, with overlap between the NOAELs and LOAELs. In all instances, the durations of exposure in shorter-term studies were less than 39 days, suggesting that physiological responses to PFOA occur early in the exposure continuum and at doses, but not necessarily average serum levels, comparable to those observed in the long term studies.

4.1.1.1 PK Model approach

In linking chemical exposure to toxic endpoints, careful consideration of PKs is crucial. This is especially true for PFOA, where inter-species and gender variation in CL half-life can vary by several orders of magnitude. If the toxicological endpoints are assumed to be driven by internal concentrations, the internal exposure needs to be calculated and considered across species. Differences in PKs (e.g., male rats excrete PFOA more slowly than females) and differences across species produce differences in the external dose needed to achieve the same internal dose. The use of the animal data and the available PK model allows for the incorporation of species differences in saturable renal resorption, dosing duration, and serum measurements for doses administered to determine HEDs based on average serum concentration and CL.

Candidate studies for RfD development were restricted to those of adequate duration (preferably > 7 weeks), multiple dose groups, use of a concurrent control, and with serum data amenable for modeling that showed the most sensitive effects following exposure to PFOA. Those studies included the subchronic study by Perkins et al. (2004), the two-generation study by Butenhoff et al. (2004a), both conducted in rats, and the Butenhoff et al. study (2002) in monkeys. Also included are the developmental studies of Lau et al. (2006) and Wolf et al. (2007)/White et al. (2009), and the DeWitt et al. study (2008) of immunotoxicity in mice that showed effects of lifetime concern despite their briefer exposure durations. Together these studies encompassed the range of doses evaluated and the LOAELs observed in other studies that lacked serum data.

The Butenhoff et al. study (2002) was included as it is the only longer-term study in a nonhuman primate and had serum PFOA data available. The dose of 3 mg/kg/day was a LOAEL for increased liver weight in the absence of clear adverse effects. The small number of animals per group (2–4) made evaluation of accompanying liver effects difficult to evaluate against the Hall et al. (2012) criteria. Thus, while included in the model for comparison of serum levels, data from Butenhoff et al. (2002) will not be considered further in the quantitative RfD assessment.

PFOA has dose-dependent kinetics. Although repeated doses rapidly result in quasi-equilibrium blood concentrations, a single dose results in a much longer half-life than is consistent with a rapid approach to quasi-equilibrium (Andersen et al. 2006; Lou et al. 2009). Using a simple, linear PK model (e.g., a one- or two-compartment model) to predict internal dose resulted in estimated HEDs from repeated exposures that were greater than the external doses supported by the experimental data (Butenhoff et al. 2004a; Lou et al. 2009). Application

of a saturable renal resorption model (Andersen et al. 2006) predicted average serum values at the time of sacrifice and the duration necessary to reach steady state.

PK data (serial blood concentrations following treatment with known quantities of PFOA) were collected for three species: cynomolgus monkey (Butenhoff et al. 2004b), Sprague-Dawley rat (Kemper 2003), and mice. Data were available for two strains of mice and these were analyzed separately: CD1 (Lou et al. 2009) and C57BL6/N (DeWitt et al. unpublished, cited in DeWitt et al [2008]). Due to the pronounced difference in the PKs of male and female rats, the two genders were fit separately. For mice, only female data were used. For monkeys a limited amount of female data was used jointly with male data, assuming the only difference between the genders for monkey was bodyweight.

For each study with a toxicological endpoint and LOAEL, the AUC and final serum concentrations were determined for the exposure duration investigated in that study. These values are summarized in Table 4-3 for rats, Table 4-4 for mice, and Table 4-5 for monkeys. In order to make a rough assessment of the validity of the model predictions, a final serum concentration was predicted for each treatment so that it could be compared to measured serum values. The predicted final serum concentration is the estimate for serum concentration at the time of sacrifice. They differed by a factor of four when strains were different and closer to a factor of two when predicted using parameters from the same strain. Because these predictions do not perfectly match the measured serum concentrations, there remains uncertainty about the exposure estimates, and this uncertainty has not been fully characterized.

Table 4-3. Predicted Final Serum Concentration and Time-Integrated Serum Concentration (AUC) for Studies in Rats

Study	Species/ Strain	Exposure Duration	Oral Doses mg/kg/day	Measured Final Serum value µg/ml	Species/ Strain Used for Prediction	Predicted Final Serum Value µg/ml	Predicted AUC mg/L*h
Perkins et al. 2004	Rat (M) ChR-CD	13 weeks Diet	0.06	7.1 (1.2)	Rat (M)	3.8 (0.0955)	7230 (181)
			0.64	41 (13)	Sprague-Dawley	34.8 (0.865)	69100 (1540)
			1.94	70 (16)		79.5 (3.84)	168000 (6520)
			6.50	138 (34)		139 (13.1)	326000 (27100)
Butenhoff et al. 2004a	Rat (M) Sprague-Dawley	F0M: 10 wk pre mating- mating Gavage	1	NT	Rat (M)	49.9 (1.53)	92500 (2600)
			3	NT	Sprague-Dawley	102 (6.5)	204000 (10900)
			10	51.5 ^s		153 (17.3)	345000 (34200)
			30	45.3		169 (27.7)	412000 (70500)

Notes: Numbers in parentheses indicate SD

M = male; s = serum; NT = not tested

Since the Kemper (2003) data were not tied to toxicological endpoints and were only used in model development, they are not included in this table.

Table 4-4. Predicted Final Serum Concentration and Time-Integrated Serum Concentration (AUC) for Studies in Mice

Study	Species/ Strain	Exposure Duration days	Oral Doses mg/kg/d	Measured Serum Value µg/ml	Species/ Strain Used for Prediction	Predicted Final Serum Value µg/ml	Predicted AUC mg/L*h
White et al. 2009; Wolf et al. 2007	Mouse (F) CD-1	GDs 1–17 ^a Gavage	3	NT	Mouse (F) CD-1	25 (2.22)	33,700 (1,860)
			5	NT		25.6 (2.26)	40,700 (2,170)
		GDs 7–17 Gavage	5	24.8	Mouse (F) CD-1	29 (2.55)	25,400 (1,320)
DeWitt et al. 2008	Mouse (F) C57BL/6N	15 days Drinking water	0.94	NTb	Mouse (F) C57BL/6N	29.7 (1.58)	7,300 (541)
			1.88	NTb		51.9 (1.89)	13,800 (951)
			3.75	35.3		70.2 (2.57)	22,400 (1,290)
			7.5	42.8		81.4 (3.91)	30,500 (1,540)
			15	50.0		94.7 (11.8)	40,100 (4,720)
			30	162.6		117 (29.3)	56,000 (12,300)
Lau et al. 2006	Mouse (F) CD-1	GDs 1–17 Gavage	1	21.9c	Mouse (F) CD-1	57.6 (3.82)	16,400 (606)
			3	40.5 c		87.2 (7.93)	33,600 (1,930)
			5	71.9 c		95.2 (7.41)	40,700 (2,180)
			10	116 c		106 (5.84)	49,600 (1,980)
			20	181 c		121 (11)	61,400 (5,050)
			40	271 c		148 (30.2)	80,100 (12,700)

Notes: Numbers in parentheses indicate SD

NA = not applicable; could not be determined

F = female; GD = gestation day; NT = not tested

^a Sacrificed on PND 22.

^b DeWitt et al. (2008) had 0.94 and 1.88 mg/kg/day dose groups in a second experiment.

^c The Lau et al. (2006) serum data were provided by the author for animals treated GDs 1–17.

Table 4-5. Predicted Final Serum Concentration and Time-Integrated Serum (AUC) in Studies of Monkeys

Study	Species/ Strain	Exposure Duration	Oral Doses mg/kg/day	Measured Serum value µg/ml	Species/ Strain Used For Prediction	Predicted Final Serum Value µg/ml	Predicted Exposure (AUC) mg/L*h
Butenhoff et al. 2002, 2004b	Monkey (M) Cyno- molgus	26 weeks Oral capsule	3 (n = 3)	117.9 (87.6-141)	Monkey Cyno- molgus	89.1 (12.4)	380,000 (50,100)
			10 (n = 4)	77.35 (55.4- 96.5)		121 (14)	553,000 (62,800)
			30/20 (n = 3)	283.2 (61.7-489)		149 (31)	710,000 (144,000)

Notes: Numbers in parentheses indicate SD

M = male

The average serum concentration for the LOAEL or NOAEL was determined through numeric simulation. The average or mean value has the advantage of normalizing the serum concentration across the exposure durations to generate a uniform metric for internal dose in situations where the dosing durations varied and serum measurements were taken immediately prior to sacrifice. The averaged serum concentration is a hybrid of the AUC and the maximum serum concentration. Compared across studies, PFOA average serum concentration appears to be a stable reflection of internal dosimetry.

Table 4-6 provides the AUC from the model, the dosing duration from each of the modeled studies, and the resultant average serum concentration. The data from the monkey study (Butenhoff et al. 2002, 2004b) were not used because of the small number of animals evaluated

and the wide variability in the responses. The internal doses associated with the effect levels (LOAELs) differ by less than an order of magnitude (13.1–96.2 mg/L), while the AUC values differ by over two orders of magnitude (5,360–380,000 mg/L*h). Given the differences in external doses, the projected serum levels are proportionally quite similar.

Table 4-6. Average Serum Concentrations Derived from the AUC and the Duration of Dosing

Study	Dosing duration days	NOAEL mg/kg/day (AUC mg/L*h)	NOAEL (Av serum mg/L)	LOAEL mg/kg/day (AUC mg/L*h)	LOAEL (Av serum mg/L)
DeWitt et al. 2008: mice; ↓ IgM response to SRBC	15	1.88 (13,800)	38.2 (2.63)	3.75 (22,400)	61.9 (3.58)
Lau et al. 2006: mice reduced pup ossification (m, f), accelerated male puberty	17	None	None	1 (16,400)	38.0 (1.4)
Perkins et al. 2004: rats; ↑liver weight/necrosis	91	0.64 (69,100)	31.6 (0.073)	1.94 (168,000)	77.4 (2.98)
Wolf et al. 2007: mice; GDs 1–17 ↓Pup body weight ^a	17	None	None	3 (33,700)	77.9 (4.3)
Wolf et al. 2007: mice; GDs 7–17 ↓Pup body weight ^a	11	None	None	5 (25,400)	87.9 (4.57)
Butenhoff et al. 2004a: ↓relative body weight/↑ relative kidney weight and ↑kidney:brain weight ratio in F0 and F1 at sacrifice	84	None	None	1 (92,500)	45.9 (1.29)

Notes: Significance $p < 0.05$ or < 0.01
 m = male; f = female; SRBC = Sheep Red Blood Cell
^a serum from pups on PND 22

Table 4-6 identifies serum values of 38, 45.9, and 61.9 mg/L as the lowest concentrations associated with adverse effects in the Lau et al. (2006), Butenhoff et al. (2004a), and DeWitt et al. (2008) studies, respectively. Thus, it appears that the LOAELs are roughly consistent across gender, species, and treatment with respect to average serum concentration. Assuming that MoA, susceptibility to toxicity, or both do not vary and that PKs alone explains variation, it is reasonable to expect similar concentrations to cause similar effects in humans.

The Andersen et al. (2006) model, used to make the predictions in Tables 4-3, 4-4, and 4-5 can be solved analytically to predict the steady-state concentration (C_{ss}) resulting from a fixed infusion DR (in units of $\mu\text{mol/h}$):

$$C_{ss} = \frac{DR}{free * Q_{fil}} \left(1 + \frac{T_{max}}{Q_{fil} * k_T + DR} \right)$$

Although the assumption of a constant infusion exposure simplifies the actual dose regimen used, this assumption permits rapid calculation and analysis of C_{ss} . Using this equation, one can calculate a range of C_{ss} values for each DR. The range of C_{ss} values are derived from the species-specific combinations of parameters from the Bayesian analysis of the available PK data. This result for C_{ss} depends nonlinearly on DR. The PFOA toxicity studies used discrete, daily doses; these doses were converted into rates by dividing daily dose by 24 hours. In Table 4-7, the C_{ss} is compared with the average serum concentration predicted. The fraction of C_{ss} is calculated, indicating that the studies range 36%–91% of C_{ss} .

For human exposure to PFOA, one needs to rely on steady-state calculations since there is a lack of both the sufficient PK and exposure knowledge to make more complicated estimates. The average serum concentrations of the LOAEL in Table 4-7 are all within roughly one order of magnitude (12.4–87.9 mg/L).

Table 4-7. Comparison of Average Serum Concentration and Steady-State Concentration

Study	Dosing duration days	LOAEL mg/kg/day	C _{ss} (mg/L) for constant infusion of LOAEL	Average Serum Conc. for Study (mg/L)	Fraction of C _{ss} (Average / C _{ss})
Perkins et al. 2004	91	1.94	84.4 (3.81)	77.4 (2.98)	0.913 (0.00746)
Butenhoff et al. 2004a	84	1	52.5 (1.72)	45.9 (1.29)	0.874 (0.00776)
Wolf et al. 2007; GDs 7–17	11	5	107 (6.8)	87.9 (4.57)	0.82 (0.0117)
Wolf et al. 2007; GDs 1–17	17	3	95.9 (6.73)	77.9 (4.3)	0.813 (0.0148)
DeWitt et al. 2008	15	3.75	84.1 (4.5)	61.9 (3.58)	0.736 (0.0233)
Lau et al. 2006	17	1	67.8 (4.39)	38 (1.4)	0.561 (0.0277)

Notes: Average serum concentrations from PK simulations of toxicity study treatment regimens and C_{ss} were both predicted using species-specific parameter distributions (i.e., draws from the Markov Chain determined by analyzing the available PK data for the appropriate species). The number in parentheses is the SD.

The predicted average serum concentrations can be converted into an oral equivalent dose by recognizing that, at steady state, CL from the body should equal dose to the body. CL can be calculated if the rate of elimination (derived from the half-life) and the V_d are both known. In making the calculation based on CL, it is important also to consider whether the exposure to PFOA has lasted long enough to reach steady state. Four of the endpoints modeled represent serum values that are greater than 80% of steady state, but none represent steady-state concentrations. Those endpoints representing lower percentages of steady state require consideration of the uncertainty resulting from use of a projection that is not representative of a steady-state concentration (UF_s) when establishing an RfD for a chronic lifetime exposure endpoint.

Measures of half-life in humans have been determined for both workers and the general population (section 2.6.2). Olsen et al. (2007) gives the human half-life as 3.8 years for PFOA in an occupationally-exposed U.S. cohort. Bartell et al. (2010) determined a value of 2.3 years based on the decline in serum levels among members of the general population exposed via drinking water in the area near the DuPont Works plant in Washington, West Virginia after the drinking water concentrations decreased. EPA chose to use the Bartell et al. (2010) half-life value because it is the one most relevant to scenarios where exposures result from ingestion of contaminated drinking water by members of the general population.

Thompson et al. (2010) gives a V_d of 0.17 L/kg_{bw} (section 2.6.3). The V_d is defined as the total amount of PFOA in the body divided by the blood or serum concentration. The V_d was calibrated using human serum concentrations and exposure data from NHANES and assumes that most PFOA intake came from contaminated drinking water. The value for V_d was calibrated so that the model prediction of elevated blood levels of PFOA was consistent with the values from NHANES. The V_d value determined by Thompson et al. (2010) did not consider PFOA contributions from sources other than drinking water. However this estimate is not radically different from the 0.198 L/kg_{bw} determined for the monkey in the study by Butenhoff et al. (2004b).

The half-life (t_½) and V_d are utilized to calculate the CL for PFOA according to the following equation assuming first order kinetics for CL (Medinsky and Klaassen 1996):

$$CL = V_d \times (\ln 2 \div t_{1/2}) = 0.17 \text{ L/kg}_{bw} \times (0.693 \div 839.5 \text{ days}) = 0.00014 \text{ L/kg bw/day}$$

Where:

$$\begin{aligned} V_d &= 0.17 \text{ L/kg} \\ \ln 2 &= 0.693 \\ t_{1/2} &= 839.5 \text{ days (2.3 years} \times 365 \text{ days/year} = 839.5 \text{ days)} \end{aligned}$$

These values combined give a CL of 1.4×10^{-4} L/kg bw/day.

Scaling the derived average serum concentrations (in mg/L) for the NOAELs and LOAELs in Table 4-6 yields the predicted oral HED in mg/kg/day for each corresponding serum measurement. The HED values are the predicted human oral exposures necessary to achieve serum concentrations equivalent to the LOAEL (and NOAEL where available) in the animal toxicity studies. Note that this scaling assumes linear first-order human kinetics in contrast to the nonlinear phenomena observed at high doses in animals. It is justifiable at the lower dose NOAEL and LOAEL concentrations from the animal studies that that demonstrate the first-order, linear response to dose necessary to calculate CL.

Thus, HED = average serum concentration (in mg/L) x CL

Where:

Average serum is from model output in Table 4-8
 CL = 0.00014 L/kg bw/day

Table 4-8. HEDs Derived from the Modeled Animal Average Serum Values

Study	Dosing duration days	NOAEL mg/kg/d	NOAEL Av serum mg/L	HED mg/kg/d	LOAEL mg/kg/d	LOAEL (Av serum) mg/L	HED mg/kg/d
DeWitt et al. 2008: mice; ↓ IgM response to SRBC	15	1.88	38.2	0.0053	3.75	61.9	0.0087
Lau et al. 2006: mice reduced pup ossification (m,f), accelerated male puberty	17	None	-	-	1	38.0	0.0053
Perkins et al. 2004: rats; ↑liver weight/necrosis	91	0.64	31.6	0.0044	1.94	77.4	0.0108
Wolf et al. 2007: mice; GDs 1–17 ↓pup body weight	17	None	-	-	3	77.9	0.0109
Wolf, et al. 2007: mice; GDs 7–17 ↓pup body weight ¹	11	None	-	-	5	87.9	0.0123
Butenhoff et al. 2004a: ↓F0 body weight/↑ absolute and relative kidney weight	84	None	-	-	1	45.9	0.0064
Macon et al. (2011) GDs 1–17 ↓mammary gland development ²	17	-	-	-	0.3	12.4	0.0017

Notes: Significance $p < 0.05$ or < 0.01

m = male; f = female; SRBC = Sheep Red Blood Cell

¹ serum from pups on PND 22

² serum from pups on PND 7

4.1.1.2 RfD Quantification

The subset of studies amenable for use in derivation of HED based on average serum measurements from the PK model is based solely on results from studies that have dose and species-specific serum values for model input, as well as exposure durations of sufficient length to achieve values near to steady-state projections or applicable to developmental endpoints with lifetime consequences following short term exposures.

As explained previously, human data identified significant relationships between serum levels and specific indicators of adverse health effects but lacked the exposure information for dose-response modeling. For this reason none of the human studies provided an appropriate POD for RfD derivation. The pharmacokinetically-modeled average serum values from the animal studies are restricted to the animal species selected for their low dose response to oral PFOA intakes. Extrapolation to humans adds a layer of uncertainty that needs to be accommodated in deriving the RfD.

HED PODs. The HEDs derived from Perkins et al. (2004), DeWitt et al. (2008), Lau et al. (2006), and Butenhoff et al. (2004a) were each examined as the potential basis for the RfD. Only Perkins et al. (2004) and DeWitt et al. (2008) identified a NOAEL from which the HED could be derived. The Lau et al. (2006) and Wolf et al. (2007)/White et al. (2009) LOAEL HEDs included developmental effects in the offspring as accompanied by the increased liver weight that is an accepted biomarker for PFOA exposure. These are developmental exposure studies that carry lifetime consequences for a less-than-lifetime exposure. The Butenhoff et al. study (2004a) included significant decreased body weight (not confounded by reduced food intake) in F0 males accompanied by increased kidney weight (consistent with the need for renal tubular transport) as co-critical at the LOAEL. The DeWitt et al. study (2008) has a LOAEL for decreased IgM, increased IgG, and increased absolute and relative spleen weight after a 15-day exposure.

Table 4-9 provides the calculations for potential RfDs using the HEDs derived from PK modeling based on the serum values collected at animal sacrifice. The table applies UFs to each POD and illustrates the array of potential RfD outcomes. Each POD is impacted by the doses utilized in the subject study, the endpoints monitored, and the animal species/gender studied. Thus, the array of outcomes, combined with knowledge of the individual study characteristics, helps to inform selection of an RfD that will be protective for humans.

The potential lifetime RfD values in Table 4-9 differ by about an order of magnitude (0.00002–0.00015 mg/kg/day) but so do the UFs applied to the POD. These results demonstrate the ability of the model to normalize the animal data across species, strain, gender, and exposure duration. The UFs applied in the derivation of the potential RfDs alter the first-order, direct relationship between the animal serum measurements associated with the animal studies and the resultant RfD. Accordingly, the resultant RfD cannot be extrapolated to a corresponding human serum value equivalent to the RfD using the CL value applied when calculating the HED from the animal serum.

Table 4-9. The Impact of Quantification Approach on the RfD Outcomes for the HEDs from the PK Model Average Serum Values

POD	Value mg/kg/day	UF _H	UF _A	UF _L	UF _S	UF _D	UF _{total}	Candidate RfD mg/kg/day
PK-HED _{NOAEL} Perkins rats; ↑liver weight/necrosis	0.0044	10	3	-	-	-	30	0.00015
PK-HED _{LOAEL} Wolf GD 1-17 mice; ↓pup body weight	0.0109	10	3	10	-	-	300	0.00004
PK-HED _{LOAEL} Wolf GD 7-17 mice; ↓pup body weight ^a	0.0123	10	3	10	-	-	300	0.00004
PK-HED _{NOAEL} DeWitt mice; ↓ IgM response to SRBC	0.0053	10	3	-	10	-	300	0.00002
PK-HED _{LOAEL} Lau mice reduced pup ossification (m,f), accelerated male puberty	0.0053	10	3	10	-	-	300	0.00002
PK-HED _{LOAEL} Butenhoff ↓F0 body weight/↑ absolute and relative kidney weight	0.0064	10	3	10	-	-	300	0.00002

Notes: m = male; f = female; SRBC = Sheep Red Blood Cell

^a serum from pups on PND 22

The Perkins et al. (2004) and Butenhoff et al. (2004a) studies were conducted in male Sprague-Dawley rats with durations of 91 days via diet and 84 days via gavage, respectively. Both were associated with increased relative liver weight accompanied by some hepatic necrosis in a small number of animals. The Butenhoff et al. study (2004a) also observed a significant decrease in body weight compared to controls for the F0 male rats at the end of the 84-day exposure. The studies by Lau et al. (2006) and Wolf et al. (2007)/White et al. (2009) were conducted in pregnant female mice with a 17-day average exposure via gavage, resulting in increased liver weights in the dams and low body weights and developmental delays in offspring.

Uncertainty Value Application

A UF for intraspecies variability (UF_H) of 10 is assigned to account for variability in the responses within the human populations because of both intrinsic (toxicokinetic genetic, life stage, health status) and extrinsic (life style) factors that can influence the response to dose. No information to support a UF_H other than 10 was available to characterize interindividual and age-related variability in the toxicokinetics or toxicodynamics among humans other than variability in serum levels measured among populations residing in common geographical locations with presumably fairly similar exposures.

A UF for interspecies variability (UF_A) of three was applied to account for uncertainty in extrapolating from laboratory animals to humans (i.e., interspecies variability). The 3-fold factor is applied to account for toxicodynamic differences between the animals and humans. The HEDs were derived using average serum values from a model to account for PK differences between animals and humans.

A UF for LOAEL to NOAEL extrapolation (UF_L) of 10 was applied to all PODs other than the Perkins et al. study (2004) to account for use of a LOAEL for the POD. The POD for the Perkins et al. study (2004) is a NOAEL.

A UF for extrapolation from a subchronic to a chronic exposure duration (UFs) is one, because the PODs are based on average serum concentrations and determined to represent > 80% of steady state for each study (81%–91%) except for the Lau et al. (2006) developmental study (56%). The Lau et al. (2006) developmental HED was not adjusted for lifetime exposures, because the average serum values associated with the developmental studies are more protective than those for the longer-term studies of systemic toxicity. A UFs of 10 was applied to the DeWitt et al. study (2008) serum-derived HED reflecting 73% of steady state because the data suggest that longer-term exposures to the same dose have the potential to increase serum values beyond the levels indicated by the 15-day exposure to mice. In addition, the NOAEL for immunological effects (0.94 mg/kg/day) was a LOAEL for effects on liver weight in the absence of histological evaluation on both days 16 and 31 following a 15-day exposure. Thus, there is a potential that lifetime exposures at serum steady state could impact the liver, increasing the risk for tissue damage.

A database UF (UF_D) of one was applied to account for deficiencies in the animal study database for PFOA. There are extensive human data from epidemiology studies in the general population, as well as in worker cohorts. The epidemiology data provide strong support for the identification of hazards observed following exposure to PFOA in the laboratory animal studies and the human relevance of the critical effects. However, uncertainties in the use of the available epidemiology data precluded their use at this time in the quantification of an RfD. There are extensive data from short term, subchronic, chronic, reproductive, developmental, and mechanistic studies in laboratory animals that support the endpoints used in calculating the potential RfD. The potential RfD is the one applicable to those most at risk from exposure to PFOA present in drinking water, the fetus and young infants. The alternative identical RfDs are values that could be more appropriate for other exposure scenarios and endpoint concerns.

4.1.2 RfD Selection

The candidate RfDs in Table 4-9 range 0.00002–0.00015 mg/kg/day. The RfD of 0.00002 mg/kg/day calculated from HED average serum values from Lau et al. (2006) was selected. The RfD based on Lau et al. (2006) is derived from reduced ossification of the proximal phalanges (forelimb and hindlimb) and accelerated puberty in male pups (4 days earlier than controls) as the critical effects. The selected RfD from the Lau et al. study (2006) is supported by the RfD for effects on the response of the immune system (DeWitt et al. 2008) to external challenges as observed following the short-term 15-day exposures to mature mice and effects on organ and body weights in F1 adult males observed following chronic exposure.

Decreased pup body weights were also observed in studies conducted by Wolf et al. (2007)/White et al. (2009) and Lu et al. (2015) using mice receiving external doses within the same order of magnitude (1, 3, and 5 mg/kg/day respectively) as those in the chosen study for the RfD. The selected RfD from the reproductive and developmental study is supported by the longer-term RfD for effects on the response of the immune system (DeWitt et al. 2008) to external challenges as observed following the short-term exposures to mature mice and the effects on kidney weight observed at the time of sacrifice in the F0 parental males in the Butenhoff et al. study (2004a) that provided the modeled serum data.

Support for the selected RfD is provided by other key studies with NOAELs and LOAELs similar to those used for quantification, yet lacked serum data that could be used for modeling. There were effects on liver weight and hepatic hypertrophy in the Perkins et al. (2004) and

DeWitt et al. (2008) studies that were not considered in the identification of the study LOAEL because of a lack of data to demonstrate adversity as determined by the Hall criteria (Hall 2012). The LOAEL for evidence of hepatic necrosis and other signs of tissue damage in the F1 male rats from the Butenhoff et al. study (2004a) was 3 mg/kg/day, and the NOAEL was 1 mg/kg/day. In the Loveless et al. study (2008), for male rats 1 mg/kg/day was a NOAEL for increased relative liver weight and focal liver necrosis was seen at a LOAEL of 10 mg/kg/day, while in male mice the NOAEL was 0.3 mg/kg/day for the increased liver weight and focal liver necrosis was at a LOAEL of 1 mg/kg/day following a 29-day exposure. In the study by Tan et al. (2013) the degree of damage to the liver at 5 mg/kg/day became more severe with increased necrosis, inflammation, and steatosis when animals were given an HFD. The HED modeled from the average serum value in mice for the LOAEL of 3 mg/kg/day from Wolf et al. (2007)/White et al. (2009) was 0.0109 mg/kg/day, about twice that of the 0.0053 mg/kg/day for the rats in the Lau et al. study (2006) at a LOAEL of 1 mg/kg/day. Both studies lacked a NOAEL.

Using the PK model of Wambaugh et al. (2013), average serum PFOA concentrations were derived from area under the curve (AUC) considering the number of days of exposure before sacrifice. The predicted serum concentrations were converted as described above to oral HEDs in mg/kg/day for each corresponding serum measurement. The POD for the derivation of the RfD for PFOA is the HED of 0.0053 mg/kg/day that corresponds to a LOAEL that represents approximately 60% of steady-state concentration. An UF of 300 (10 UF_H, 3 UF_A, and 10 UF_L) was applied to the HED LOAEL to derive an RfD of 0.00002 mg/kg/day.

There are extensive human data from epidemiology studies on the general population, as well as worker cohorts. The epidemiology data provide support for the human relevance of the hazards identified in the laboratory animals. However, they lack the quantitative information on the human exposures (doses and durations) responsible for the human serum levels. Although some associations show a relationship between effects and serum measures, the serum measures are lower than the PODs from the animal studies and some associations are confounded by reverse causality. Data supporting a first-order kinetic relationship between dose/duration and serum concentrations are needed before the human data can be used in a manner comparable to the process utilized in the RfD derivation.

4.1.3 RfC Determination

Limited data from human epidemiology and animal toxicity studies were available with which to evaluate the potential health effects resulting from continuous inhalation exposure to PFOA. The available data base, summarized below for human and animal data, does not provide the minimum data needed for derivation of the RfC as discussed in USEPA (1994b). Thus, the RfC for PFOA is not recommended or derived.

Human Data. Studies have examined occupational and residential populations at or near large-scale PFOA production plants in the United States in an attempt to determine the relationship between serum PFOA concentration and various health outcomes suggested by the standard animal toxicological database. While inhalation is an important route of exposure to workers, drinking water was identified as a contributor to exposure in the general population. In all of the epidemiology studies, wide ranges of serum levels were reported that are likely a reflection, not only of intra-human toxicokinetic variability, but also of diversity in external exposure sources and routes of exposure. Thus, the data cannot be clearly applied to quantification of dose-response via inhalation.

Animal Data. Inhalation toxicity data in laboratory animals were limited to acute, single, and repeated exposures for PK studies, and a developmental toxicity study in rats. No subchronic or chronic inhalation toxicity studies in animals were available for assessment. Generally, adverse effects observed following inhalation exposure to PFOA were similar to effects following exposure to an irritating dust. For male rats exposed to PFOA as a dust in air, the 4-hour LC₅₀ was 980 mg/m³, with adverse clinical signs of body weight loss, irregular breathing, red discharge around the nose and eyes, and corneal opacity and corrosion (Kennedy et al. 1986, 2004).

Distinct toxicokinetic differences between male and female rats were found following single and repeated inhalation exposures. Sprague-Dawley rats were exposed nose-only to PFOA aerosols of 0, 1, 10, or 25 mg/m³ for 6 hours or for 6 hours/day, 5 days/week, for 3 weeks (Hinderliter 2003). Absorption was indicated in both males and females after single and repeated exposures with plasma PFOA concentrations proportional to exposure concentration. The C_{max} values were approximately 2–3 times higher in males than in females and persisted for up to 6 hours in males compared to just 1 hour in females. Similarly, the elimination of PFOA was rapid by females at all exposure levels, and by 12 hours after exposure the plasma levels had dropped below the analytical LOQ (0.1 µg/ml). In males, the plasma concentration remained approximately 90% of the peak concentration at all exposure levels at 24 hours after exposure, and steady state was reached following repeated exposures. While these results clearly show toxicokinetic differences between male and female rats, toxicity data were not included, limiting use of the information in a quantitative risk assessment.

In a developmental toxicity study, pregnant Sprague-Dawley rats were exposed whole-body to PFOA dust concentrations of 0, 0.1, 1, 10, or 25 mg/m³ for 6 hours/day on GDs 6–15 (Staples et al. 1984). Dams were either sacrificed on GD 21 or allowed to litter and rear their offspring until PND 35. Maternal toxicity at 10 and 25 mg/m³ consisted of wet abdomens, chromodacryorrhea, chromorhinorrhea, a general unkempt appearance, lethargy (high-concentration group only), and decreased body weight and food consumption. Five out of 24 dams died during treatment at 25 mg/m³. Significantly increased mean liver weight (p<0.05) was seen at 25 mg/m³. No effects were observed on the maintenance of pregnancy or fetal and pup survival. At 25 mg/m³, mean offspring body weight was lower than that of controls on GD 21 and throughout lactation.

4.2 Dose-Response for Cancer Effects

As discussed in section 3.4.5, there is equivocal evidence that PFOA exposure might be associated with an increased risk for cancer from the human epidemiology database and animal studies. Only one study in highly exposed worker populations showed a positive association between death from cancer and PFOA exposure. In that study, a significant increase in mortality due to kidney cancer was found for workers in the highest quartile of cumulative PFOA exposure; the estimated average mean serum level was 0.35 µg/mL (Steenland and Woskie 2012). Mortality from cancer in PFOA workers was not elevated in several other studies (Leonard et al. 2008; Lundin et al. 2009; Raleigh et al. 2014). Serum levels were not available in studies reporting only mortality. No association was found between PFOA level and cancer incidence rate in workers with mean serum of 0.113 µg/mL (Steenland et al. 2015).

No associations were found in the general population between mean serum PFOA levels up to 0.0866 µg/mL and colorectal, breast, prostate, bladder, and liver cancer (Bonefeld-Jørgensen

et al. 2014; Eriksen et al. 2009; Hardell et al. 2014; Innes et al. 2014). In contrast, two studies involving members of the C8 Health Project showed a positive association between PFOA levels (mean at enrolment 0.024 µg/mL) and kidney and testicular cancers (Barry et al. 2013; Vieira et al. 2013).

The only chronic bioassays of PFOA were conducted in rats (Biegel et al. 2001; Butenhoff et al. 2012). The two studies support a positive finding for the ability of PFOA to be weakly tumorigenic in one or more organs of male but not female rats. There are no carcinogenicity data from a second animal species. The study by Butenhoff et al. (2012) examined male and female rats; the Biegel et al. study only evaluated males. The tumor types observed were:

- Liver (Butenhoff et al. 2012).
- Leydig Cell (Biegel et al. 2001; Butenhoff et al. 2012).
- Pancreatic Ascinar Cell (Biegel et al. 2001).

The dose response information and tumors incidence data from the Butenhoff et al. (2012) and Biegel et al. (2001) studies are summarized in Table 4-10. The data are limited in that only Butenhoff et al. tested more than one dose. Only one tumor-type (Leydig cell adenoma) demonstrated a dose-response relationship.

Table 4-10. Summary of Tumor Data from Animal Studies

Tissue	Concentration in Diet (ppm)			Tumor Type	Reference
	0 ^a	30	300		
Liver Male	7/50	2/50	10/50	Hepatocellular carcinoma	Butenhoff et al. 2012
Liver Male	0/80	NT	0/76	Hepatocellular carcinoma	Biegel et al. 2001
Liver Male	2/80	NT	10/76	Hepatocellular adenoma	Biegel et al. 2001
Liver Female	0/50	0/50	2/50	Hepatocellular carcinoma	Butenhoff et al. 2012
Testes Male	0/50	2/50	7/50	Leydig Cell adenomas	Butenhoff et al. 2012
Testes Male	0/80	NT	8/76	Leydig Cell adenomas	Biegel et al. 2001
Pancreas Male	1/80	NT	0/76	Acinar Cell carcinoma	Biegel et al. 2001
Pancreas Male	0/80	NT	7/76	Acinar Cell adenoma	Biegel et al. 2001

Notes: ^a The value reported is for the ad libitum control
 NT = Not tested

There are some data that provide support for the hypothesis that the PPAR α agonism is the MOA for the observed liver tumors in rats. PPAR α is found in human livers and, when activated, is linked through activation to a number of metabolic responses but not to the large-scale peroxisome proliferation associated with tumors in rats and other rodent species. The data support a PPAR α MOA for the liver tumors and, thus, are indicative of lack of relevance to humans.

PPAR α activation might also play a role in the other tumor types observed. However for the Leydig tumors the PPAR α involvement is indirect. The favored hypothesis for the DNA replication errors responsible for induction of Leydig tumors are postulated to be a consequence of the following sequence of events:

- Decreased testosterone synthesis.
- Increased GnRH and increased levels of LH leading to chronic stimulation of Leydig cells by growth-stimulating mediators including IGF-1, TGF- α , leukotrienes and various free radicals (Clegg et al. 1997; Li et al. 2011).

There are some experimental data that demonstrate systemic effects of PFOA leading to decreased testosterone and increased estradiol as a result of increased activity of aromatase, the cellular enzyme responsible for the metabolic conversion of testosterone to estradiol (Biegel et al. 1995). However, more data to support the relationship of PFOA to intermediate steps in the proposed MOAs are needed.

Current MOA theories for the PACT tumors are linked to the impact of either the mitogenic effects of elevated testosterone levels or intestinal tissue hormones (CCK, gastrin, or both) in promoting proliferation of acinar cell preneoplastic foci (Klaunig et al. 2003; Obourn et al. 1997). PACT tumors are most commonly found in rats but also occur in humans. Because PFOA is associated with decreased rather than increased levels of testosterone, the mechanistic link between PFOA exposure and PACT is more likely associated with gastric hormone changes, possibly associated with alterations in bile composition. Some of the membrane transporters that are impacted by PFOA function in transport of bile components from the liver to the gallbladder and thereby to the intestines. Cholecystokinin and gastrin stimulate contraction of the gallbladder and release of bile into the intestines. Data to support this hypothesis are not available for PFOA. Obourn et al. (1997) studied the impact of PFOA on CCK using *in vitro* assays and found that it was not an agonist for the CCKA receptor that activates CCK release.

The increase in hepatocellular tumors did not show a direct relationship to dose in male rats and was not significantly elevated in either males or females at the high dose when compared to controls.

There was a dose-related significant increase in LCTs in male rats in the Butenhoff et al. study (2012), which was confirmed by the high dose in the single-dose mechanistic study by Biegel et al. (2001). At the high dose (300 ppm in the diet; 14.2 mg/kg/day), tumors were found in 14% of the male rats at the end of 2 years in the Butenhoff et al. study (2012) and 4% at the low dose (1.3 mg/kg/day). In the Biegel et al. study (2001), 11% were affected at a dose of 300 ppm in the diet (13.6 mg/kg/day). In each case, there were no LCTs in the controls. The PACT tumors, only detected in the single dose Biegel et al. study (2001), do not support quantification.

Under the EPA 2005 cancer guidelines, the evidence for the carcinogenicity of PFOA is considered *suggestive* because only one species has been evaluated for lifetime exposures and the tumor responses occurred primarily in males. Dose-response data are only available for the LCTs in one study. However, two studies involving members of the C8 Health Project showed a positive association between PFOA levels (mean at enrolment of 0.024 µg/mL) and kidney and testicular cancers (Barry et al. 2013; Vieira et al. 2013). Therefore, the data on LCTs from Butenhoff et al. (2012) were modeled to provide a perspective on the magnitude of the potential cancer risk as it compares with the level of protection provided by the RfD.

The dose-response for the LCTs from Butenhoff et al. (2012) was modeled using EPA's Benchmark Dose Software (BMDS) Version 2.3.1. The multistage cancer model predicted the dose at which a 4% increase in tumor incidence would occur. The 4% was chosen as the low-end of the observed response range within the Butenhoff et al. (2012) results. Both the first and second degree polynomials gave identical goodness-of-fit criteria (p value and Akaike's Information Criterion [AIC]). Results are shown in Table 4-11 and Figure 4-1 and details of the model run are given in Appendix A.

Table 4-11. Multistage Cancer Model Dose Prediction Results for a 4% Increase in LCT Incidence

	BMD (mg/kg/day)	BMDL (mg/kg/day)
First Degree Polynomial Fit	3.51	1.99
Second Degree Polynomial Fit	3.51	1.99
AIC = 62.6936	P = 0.2245	

Source: Butenhoff et al. (2012)

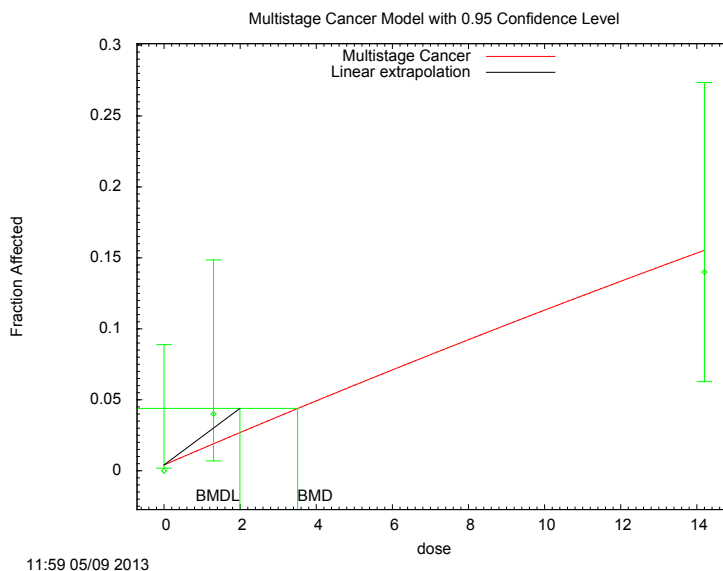

Figure 4-1. BMD Model Results for LCTs (Butenhoff et al. 2012)

The CSF for PFOS is derived from the BMDL₀₄ of 1.99 mg/kg/day after converting the animal BMDL to a HED using body weights to the ³/₄ power. The HED is calculated as follows²:

$$\text{HED} = \text{Animal BMDL} \times (\text{animal body weight})^{1/4} \div (\text{human body weight})^{1/4}$$

$$\text{HED} = 1.99 \text{ mg/kg/day} \times [(0.523 \text{ kg})^{1/4} \div (70 \text{ kg})^{1/4}] = 1.99 \text{ mg/kg/day} \times 0.29 = 0.58 \text{ mg/kg/day}$$

Where:

$$\begin{aligned} 1.99 \text{ mg/kg/day} &= \text{BMDL}_{04} \text{ for LCTs} \\ 0.29 &= \text{The dosimetric adjustment factor} \end{aligned}$$

The CSF is calculated from the BMDL₀₄ HED as follows

$$\text{CSF} = \text{response} \div \text{BMDL}_{04} \text{ HED}$$

$$\text{CSF} = 0.04 \div 0.58 \text{ mg/kg/day} = 0.07 \text{ (mg/kg/day)}^{-1}$$

² Body weight for male Sprague-Dawley rats (chronic Exposures) USEPA 1988

The CSF should not be used at doses > 0.58 mg/kg/day, the HED corresponding to the POD for the 4% incidence of LCTs following lifetime exposure to PFOA. The observed dose-response relationships do not continue linearly above this level, and the fitted dose-response models better characterize the dose-response for the higher exposures. The calculated concentration in drinking water with one-in-a-million risk for an increase in testicular tumors at levels greater than background is 0.0005 mg/L.

$$10^{-6} \text{ Cancer Risk Concentration} = 0.000001 \times 80 \text{ kg} \div [0.07 \text{ (mg/kg/day)} - 1 \times 2.5 \text{ L/day}] = 0.000457 \text{ mg/L (rounded to 0.0005 mg/L).}$$

The equivalent concentration derived from the RfD for noncancer effects using default adult body weight of 80 kg and a default DWI rate of 2.5 L/day (USEPA 2011) and a 20% relative source contribution (RSC) to account for the contribution of drinking water to the total exposure is 0.0001 mg/L. The 0.0001 mg/L concentration derived for an adult based on the RfD for noncancer effects with a 20% RSC for drinking water is lower than the concentration of 0.0005 mg/L associated with a one-in-a-million risk for testicular cancer also derived with adult default values indicating that a guideline derived from the developmental endpoint will be protective for the cancer endpoint.

5 REFERENCES

- Abbott, B.D., C.J. Wolf, J.E. Schmid, K.P. Das, R.D. Zehr, L. Helfant, S. Nakayama, A.B. Lindstrom, M.J. Styrnar, and C. Lau. 2007. Perfluorooctanoic acid-induced developmental toxicity in the mouse is dependent on expression of peroxisome proliferator-activated receptor- α . *Toxicological Sciences* 98:571–581.
- Ahuja, V., M. Eisenblätter, R. Ignatius, and R. Stahlmann. 2009. Ammonium perfluorooctanoate substantially alters phenotype and cytokine secretion of human monocyte-derived dendritic cells *in vitro*. *Immunopharmacology & Immunotoxicology* 31:641–646.
- Albrecht, P.P., N.E. Torsell, P. Krishnan, D.J. Ehresman, S.R. Frame, S.-C. Chang, J.L. Butenhoff, G.L. Kennedy, F.J. Gonzalez, and J.M. Peters. 2013. A species difference in the peroxisome proliferator-activated receptor α -dependent response to the developmental effects of perfluorooctanoic acid. *Toxicological Sciences* 131:568–582.
- Alexander, B.H. 2001a. *Mortality Study of Workers Employed at the 3M Cottage Grove Facility*. Final Report. April 26, 2001. Division of Environmental and Occupational Health, School of Public Health, University of Minnesota. U.S. Environmental Protection Agency Administrative Record 226-1030a018.
- Alexander, B.H. 2001b. *Mortality Study of Workers Employed at the 3M Decatur Facility*. Final Report. April 26, 2001. Division of Environmental and Occupational Health, School of Public Health, University of Minnesota. U.S. Environmental Protection Agency Administrative Record 226-1030a019.
- Andersen, M.E., H.J. Clewell 3rd, Y.-M. Tan, J.L. Butenhoff, and G.W. Olsen. 2006. Pharmacokinetic modeling of saturable, renal resorptions of perfluoroalkylacids in monkeys-probing the determinants of long plasma half-lives. *Toxicology* 227:156–164.
- Andersen, C.S., C. Fei, M. Gamborg, E.A. Nohr, T.I.A. Sørensen, and J. Olsen. 2010. Prenatal exposures to perfluorinated chemicals and anthropometric measures in infancy. *American Journal of Epidemiology* 172:1230–1237.
- Andersen, C.S., C. Fei, M. Gamborg, E.A. Nohr, T.I.A. Sørensen, and J. Olsen. 2013. Prenatal exposures to perfluorinated chemicals and anthropometry at 7 years of age. *American Journal of Epidemiology* 178:921–927.
- Anzai, N., Y. Kanai, and H. Endou. 2006. Organic anion transporter family: current knowledge. *Journal of Pharmacological Sciences* 100:411–426.
- Aoyama, T., J.M. Peters, N. Iritani, T. Nakajima, K. Furihata, T. Hashimoto, and F.J. Gonzalaz. 1998. Altered constitutive expression of fatty acid-metabolizing enzymes in mice lacking the peroxisome proliferator-activated receptor α (PPAR α). *Journal of Biological Chemistry* 273:5678–5684.
- Apelberg, B.J., F.R. Witter, J.B. Herbstman, A.M. Calafat, R.U. Halden, L.L. Needham, and L.R. Goldman. 2007. Cord serum concentrations of perfluorooctane sulfonate (PFOS) and perfluorooctanoate (PFOA) in relation to weight and size at birth. *Environmental Health Perspectives* 115:1670–1676.

- ATSDR (Agency for Toxic Substances and Disease Registry). 2015. *Toxicological Profile for Perfluoroalkyls*. Draft for Public Comment. Agency for Toxic Substances and Disease Registry, Public Health Service, U.S. Department of Health and Human Services, Atlanta, GA. Accessed May 2016. <http://www.atsdr.cdc.gov/ToxProfiles/tp200.pdf>.
- Augustine, L.M., R.J. Markelewicz, Jr., K. Boekelheide, and N.J. Cherrington. 2005. Xenobiotic and endobiotic transporter mRNA expression in the blood-testis barrier. *Drug Metabolism and Disposition* 33(1):182–189.
- Bach, C.C., B.H. Bech, N. Brix, E.A. Nohr, J.P.E. Bonde, and T.B. Henriksen. 2014 (epub). Perfluoroalkyl and polyfluoroalkyl substances and human fetal growth: A systematic review. *Critical Reviews in Toxicology* 45(1):53–67.
- Bach, C.C., Z. Liew, B.H. Bech, E.A. Nohr, C. Fei, E.C. Bonefeld-Jørgensen, T.B. Henriksen, and J. Olsen. 2015. Perfluoroalkyl acids and time to pregnancy revisited: An update from the Danish National Birth Cohort. *Environmental Health* 14:59–67.
- Barrett, E.S., C. Chen, S.W. Thurston, L.S. Haug, A. Sabaredzovic, F.N. Fjeldheim, H. Frydenberg, S.F. Lipson, P.T. Ellison, and I. Thune. 2015. Perfluoroalkyl substances and ovarian hormone concentrations in naturally cycling women. *Fertility and Sterility* 103(5):1261–1270.
- Barry, V., A. Winqvist, and K. Steenland. 2013. Perfluorooctanoic acid (PFOA) exposures and incident cancers among adults living near a chemical plant. *Environmental Health Perspectives* 121:1313–1318.
- Barry, V., L.A. Darrow, M. Klein, A. Winqvist, and K. Steenland. 2014. Early life perfluorooctanoic acid (PFOA) exposure and overweight and obesity risk in adulthood in a community with elevated exposure. *Environmental Research* 132:62–69.
- Bartell, S.M., A.M. Calafat, C. Lyu, K. Kato, P.B. Ryan, and K. Steenland. 2010. Rate of decline in serum PFOA concentrations after granular activated carbon filtration at two public water systems in Ohio and West Virginia. *Environmental Health Perspectives* 118:222–228.
- Beesoon, S., G.M. Webster, M. Shoeib, T. Harner, J.P. Benskin, and J.W. Martin. 2011. Isomer profiles of perfluorochemicals in matched maternal, cord, and house dust samples: Manufacturing sources and transplacental transfer. *Environmental Health Perspectives* 119:1659–1664.
- Beesoon, S., and J.W. Martin. 2015. Isomer specific binding affinity of perfluorooctanesulfonate (PFOS) and perfluoropctanoate (PFOA) to serum proteins. *Environmental Science & Technology* 49:5722–5731.
- Benskin, J.P., A.O. De Silva, L.J. Martin, G. Arsenault, R. McCrindle, N. Riddell, S.A. Mabury, and J.W. Martin. 2009. Disposition of perfluorinated acid isomers in Sprague-Dawley rats: Part 1: Single dose. *Environmental Toxicology and Chemistry* 28:542–554.
- Berg, V., T.H. Nøst, S. Hansen, A. Elverland, A.-S. Veyhe, R. Jorde, J.Ø. Odland, and T.M. Sandanger. 2015. Assessing the relationship between perfluoroalkyl substances, thyroid hormones and binding proteins in pregnant women; a longitudinal mixed effects approach. *Environment International* 77:63–69.

- Berthiaume, J., and K.B. Wallace. 2002. Perfluorooctanoate, perfluorooctanesulfonate, and N-ethyl perfluorooctanesulfonamido ethanol; peroxisome proliferation and mitochondrial biogenesis. *Toxicology Letters* 129:23–32.
- Berg, V., T.H. Nøst, S. Hansen, A. Elverland, A.-S. Veyhe, R. Jorde, J.Ø. Odland, and T.M. Sandanger. 2015. Assessing the relationship between perfluoroalkyl substances, thyroid hormones and binding proteins in pregnant women; a longitudinal mixed effects approach. *Environment International* 77:63–69.
- Best, N.G., M.K. Cowles, and K. Vines. 1995. CODA: Convergence diagnosis and output analysis for Gibbs sampling output. Technical Report, MRC Biostatistics Unit, University of Cambridge.
- Biegel, L.G., R.C.M. Liu, M.E. Hurtt, and J.C. Cook. 1995. Effects of ammonium perfluorooctanoate on Leydig cell function: *in vitro*, *in vivo* and *ex vivo* studies. *Toxicology and Applied Pharmacology* 134:18–25.
- Biegel, L.B., M.E. Hurtt, S.R. Frame, J.C. O’Conner, and J.C. Cook. 2001. Mechanisms of extrahepatic tumor induction by peroxisome proliferators in male CD rats. *Toxicological Sciences* 60:44–55.
- Bjork, J.A. and K.B. Wallace. 2009. Structure-activity relationships and human relevance for perfluoroalkyl acid-induced transcriptional activation of peroxisome proliferation in liver cell cultures. *Toxicological Sciences* 111:89–99.
- Bjork, J.A., J.L. Butenhoff, and K.B. Wallace. 2011. Multiplicity of nuclear receptor activation by PFOA and PFOS in primary human and rat hepatocytes. *Toxicology* 228:8–17.
- Bloom, M.S., K. Kannan, H.M. Spiethoff, L. Tao, K.M. Aldous, and J.E. Vena. 2010. Exploratory assessment of perfluorinated compounds and human thyroid function. *Physiology & Behavior* 99:240–245.
- Bonefeld-Jørgensen, E.C., M. Long, R. Bossi, P. Ayotte, G. Asmund, T. Krüger, M. Ghisari, G. Mulvad, P. Kern, P. Nzulumiki, and E. Dewailly. 2011. Perfluorinated compounds are related to breast cancer risk in Greenlandic Inuit: A case control study. *Environmental Health* 10:88.
- Bonefeld-Jørgensen, E.C., M. Long, S.O. Fredslund, R. Bossi, and J. Olsen. 2014. Breast cancer risk after exposure to perfluorinated compounds in Danish women: a case-control study nested in the Danish National Birth Cohort. *Cancer Causes & Control* 25(11):1439–1448.
- Brede, E., M. Wilhelm, T. Göen, J. Müller, K. Rauchfuss, M. Kraft, J. Hölzer. 2010. Two-year follow-up biomonitoring pilot study of residents’ and controls’ PFOA plasma levels after PFOA reduction in public water system in Arnsberg, Germany. *International Journal of Hygiene & Environmental Health* 213(3):217–223.
- Brieger, A., N. Bienefeld, R. Hasan, R. Goerlich, and H. Haase. 2011. Impact of perfluorooctanesulfonate and perfluorooctanoic acid on human peripheral leukocytes. *Toxicology In Vitro* 25(4):960–968.

- Buck Louis, G.M., Z. Chen, E.F. Schisterman, S. Kim, A.M. Sweeney, R. Sundaram, C.D. Lynch, R.E. Gore-Langton, and D.B. Barr. 2015. Perfluorochemicals and human semen quality: The LIFE study. *Environmental Health Perspectives* 123(1):57–63.
- Burris, J.M., G. Olsen, C. Simpson, and J. Mandel. 2000. *Determination of Serum Half-lives of Several Fluorochemicals*. 3M Company. Interim Report #1. June 8, 2000. U.S. Environmental Protection Agency Administrative Record 226-0611.
- Burris, J.M., J.K. Lundberg, G.W. Olsen, D. Simpson, and G. Mandel. 2002. *Determination of Serum Half-lives of Several Fluorochemicals*. 3M Company. Interim Report #2. January 11, 2002. U.S. Environmental Protection Agency Administrative Record 226-1086.
- Butenhoff, J., G. Costa, C. Elcombe, D. Farrar, K. Hansen, H. Iwai, R. Jung, G. Kennedy, P. Lieder, G. Olsen, and P. Thomford. 2002. Toxicity of ammonium perfluorooctanoate in male cynomolgus monkeys after oral dosing for 6 months. *Toxicological Sciences* 69:244–257.
- Butenhoff, J.L., G.L. Kennedy, S.R. Frame, J.C. O’Conner, and R.G. York. 2004a. The reproductive toxicology of ammonium perfluorooctanoate (APFO) in the rat. *Toxicology* 196:95–116.
- Butenhoff, J.L., G.L. Kennedy Jr, P.M. Hinderliter, P.H. Lieder, R. Jung, J.K. Hansen, G.S. Gorman, P.E. Noker, and P.J. Thomford. 2004b. Pharmacokinetics of perfluorooctanoate in cynomolgus monkeys. *Toxicological Sciences* 82(2):394–406.
- Butenhoff, J.L., G.L. Kennedy, Jr., S.-C. Chang, and G.W. Olsen. 2012. Chronic dietary toxicity and carcinogenicity study with ammonium perfluorooctanoate in Sprague-Dawley rats. *Toxicology* 298:1–13.
- C8 Science Panel. 2012. C8 Probable Link Reports. Accessed May 2016. <http://www.c8sciencepanel.org/index.html>.
- Calafat, A.M., L.-Y. Wong, Z. Kuklennyik, J.A. Reidy, and L.L. Needham. 2007a. Polyfluoroalkyl chemicals in the U.S. population: data from the National Health and Nutrition Examination Survey (NHANES) 2003-2004 and comparisons with NHANES 1999-2000. *Environmental Health Perspectives* 115(11):1596–1602.
- Calafat, A.M., Z. Kuklennyik, J.A. Reidy, S.P. Caudill, J.S. Tully, and L.L. Needham. 2007b. Serum concentrations of 11 polyfluoroalkyl compounds in the US population: data from the National Health and Nutrition Examination Survey (NHANES) 1999-2000. *Environmental Science & Technology* 41(7):2237–2242.
- Cameron, R.G., K. Imaida, H. Tsuda, and N. Ito. 1982. Promotive effects of steroids and bile acids on hepatocarcinogenesis initiated by diethylnitrosamine. *Cancer Research* 42:2426–2428.
- Carpino, A., V. Rago, V. Rezzi, C. Carani, and S. Andò. 2007. Detection of aromatase and estrogen receptors (Er α , Er β ₁, Er β ₂) in human Leydig cell tumor. *European Journal of Endocrinology* 157: 239–244.

- CDC (Centers for Disease Control and Prevention). 2009. *Fourth National Report on Human Exposure to Environmental Chemicals*. U.S. Department of Health and Human Services, Centers for Disease Control and Prevention, Atlanta, GA. Accessed May 2016. <http://www.cdc.gov/exposurereport/pdf/fourthreport.pdf>.
- CDC (Centers for Disease Control and Prevention). 2015. *Fourth National Report on Human Exposures to Environmental Chemicals: Updated Tables, February 2015*. U.S. Department of Health and Human Services, Centers for Disease Control and Prevention, Atlanta, GA. Accessed May 2016. http://www.cdc.gov/biomonitoring/pdf/FourthReport_UpdatedTables_Feb2015.pdf.
- Chan, E., I. Burstyn, N. Cherry, F. Bamforth, and J.W. Martin. 2011. Perfluorinated acids and hypothyroxinemia in pregnant women. *Environmental Research* 111:559–564.
- Chandra, M., M.G.I. Riley, and D.E. Johnson. 1992. Spontaneous neoplasms in aged Sprague-Dawley rats. *Archives of Toxicology* 66:496–502.
- Chang, E.T., H. Adami, P. Boffetta, C. Cole, T.B. Starr, and J.S. Mandel. 2014. A critical review of perfluorooctanoate and perfluorooctanesulfonate exposure and cancer risk in humans. *Critical Reviews in Toxicology* 44(51):1–81.
- ChemIDPlus. 2004. U.S. National Library of Medicine, Bethesda, MD. Accessed May 2016. <http://chem2.sis.nlm.nih.gov/chemidplus/>.
- Chen, M.-H., E.-H. Ha, T.-W. Wen, Y.-N. Su, G.-W. Lien, C.-Y. Chen, P.-C. Chen, and W.-S. Hsieh. 2012. Perfluorinated compounds in umbilical cord blood and adverse birth outcomes. *PLoS One* 7(8):e42474.
- Chen, H., P. He, H. Rao, F. Wang, H. Liu, and J. Yao. 2015. Systematic investigation of the toxic mechanism of PFOA and PFOS on bovine serum albumin by spectroscopic and molecular modeling. *Chemosphere* 129:217–224.
- Cheng, X., J. Maher, H. Lu, and C.D. Klaassen. 2006. Endocrine regulation of gender-divergent mouse organic anion-transporting polypeptide (Oatp) expression. *Molecular Pharmacology* 70:1291–1297.
- Cheng, X., and C.D. Klaassen. 2008. Critical role of PPAR α in perfluorooctanoic acid- and perfluorodecanoic acid-induced downregulation of Oatp uptake transporters in mouse livers. *Toxicological Sciences* 106:37–45.
- Cheng, X., and C.D. Klaassen. 2009. Tissue distribution, ontogeny, and hormonal regulation of xenobiotic transporters in mouse kidneys. *Drug Metabolism and Disposition* 37:2178–2185.
- Christensen, K.Y., M. Maisonet, C. Rubin, A. Holmes, A.M. Calafat, K. Kato, W.D. Flanders, J. Heron, M.A. McGeehin, and M. Marcus. 2011. Exposure to polyfluoroalkyl chemicals during pregnancy is not associated with offspring age at menarche in a contemporary British cohort. *Environment International* 37:129–135.
- Christopher, B., and A.J. Marias. 1977. *28-Day Oral Toxicity Study with FC-143 in Albino Mice*. Final Report, Industrial Bio-Test Laboratories, Inc. Study No. 8532-10655, 3M Reference No. T-1742CoC, Lot 269.

- Clegg, E.D., J.C. Cook, R.E. Chapin, P.M.D. Foster, and G.P. Daston. 1997. Leydig cell hyperplasia and adenoma formation: mechanisms and relevance to humans. *Reproductive Toxicology* 11:107–121.
- Considine, R.V., M.K. Sinha, M.L. Heiman, A. Kriauciunas, T.W. Stephens, M.R. Nyce, J.P. Ohannesian, C.C. Marco, L.J. McKee, T.L. Bauer, and J.F. Caro. 1996. Serum immunoreactive-leptin concentrations in normal-weight and obese humans. *New England Journal of Medicine* 334:292–295.
- Cook, J.C., S.M. Murray, S.R. Frame, and M.E. Hurtt. 1992. Induction of Leydig cell adenomas by ammonium perfluorooctanoate: A possible endocrine-related mechanism. *Toxicology and Applied Pharmacology* 113:209–217.
- Corley, R.A., A.L. Mendrala, F.A. Smith, D.A. Staats, M.L. Gargas, R.B. Conolly, M.E. Andersen, and R.H. Reitz. 1990. Development of a physiologically based pharmacokinetic model for chloroform. *Toxicology and Applied Pharmacology* 103:512–527.
- Corsini, E., E. Sangiovanni, A. Avogadro, V. Galbiati, B. Viviani, M. Marinovich, C.L. Galli, M. Dell'Agli, and D.R. Germolec. 2012. In vitro characterization of the immunotoxic potential of several perfluorinated compounds (PFCs). *Toxicology and Applied Pharmacology* 258(2):248–255.
- Corsini, E., R.W. Luebke, D.R. Germolec, and J.C. DeWitt. 2014. Perfluorinated compounds: Emerging POPs with potential immunotoxicity. *Toxicology Letters* 230(2):263–270.
- Costa, G., S. Sartori, and D. Consonni. 2009. Thirty years of medical surveillance in perfluorooctanoic acid production workers. *Journal of Occupational and Environmental Medicine* 51:364–372.
- Cui, L., Q. Zhou, C. Liao, J. Fu, and G. Jiang. 2009. Studies on the toxicological effects of PFOA and PFOS on rats using histological observation and chemical analysis. *Archives of Environmental Contamination and Toxicology* 56:338–349.
- Cui, L., C. Liao, Q. Zhou, T. Xia, Z. Yun, and G. Jiang. 2010. Excretion of PFOA and PFOS in male rats during a subchronic exposure. *Archives of Environmental Contamination and Toxicology* 58:205–213.
- D'Alessandro, M.L., D.A. Ellis, J.A. Carter, N.L. Stock, and R.E. March. 2013. Competitive binding of aqueous perfluorooctanesulfonic acid and ibuprofen with bovine serum albumin studied by electrospray ionization mass spectrometry. *International Journal of Mass Spectrometry* 345–347:28–36.
- Dankers, A.C., M.J.E. Roelofs, A.H. Piersma, F.C.G.J. Sweep, F.G.M. Russel, M. van den Berg, M.B.M. van Duursen, and R. Masereeuw. 2013. Endocrine disruptors differentially target ATP-binding cassette transporters in the blood-testis barrier and affect Leydig cell testosterone secretion *in vitro*. *Toxicological Sciences* 136(2):382–391.
- Darrow, L.A., C.R. Stein, and K. Steenland. 2013. Serum perfluorooctanoic acid and perfluorooctane sulfonate concentrations in relation to birth outcomes in the Mid-Ohio Valley, 2005-2010. *Environmental Health Perspectives* 121:1207–1213.

- Darrow, L.A., P.P. Howards, A. Winqvist, and K. Steenland. 2014. PFOA and PFOS serum levels and miscarriage risk. *Epidemiology* 25:e1–e8.
- Davies, B., and T. Morris. 1993. Physiological parameters in laboratory animals and humans. *Pharmaceutical Research* 10(7):1093–1095.
- de Cock, M., M.R. de Boer, M. Lamoree, J. Legler, and M. van de Bor. 2014. Prenatal exposure to endocrine disrupting chemicals in relation to thyroid hormone levels in infants – a Dutch prospective cohort study. *Environmental Health* 13:106.
- Dean, W.P., and D.C. Jessup. 1978. *Acute Oral Toxicity (LD50) Study in Rats*. International Research and Development Corporation, Study No. 137-091, May 5, 1978. U.S. Environmental Protection Agency Administrative Record 226-0419.
- DeWitt, J.C., C.B. Copeland, M.J. Strynar, and R.W. Luebke. 2008. Perfluorooctanoic acid-induced immunomodulation in adult C57BL/6J or C57BL/6N female mice. *Environmental Health Perspectives* 116:644–650.
- DeWitt, J.C., C.B. Copeland, and R.W. Luebke. 2009. Suppression of humoral immunity by perfluorooctanoic acid is independent of elevated serum corticosterone concentration in mice. *Toxicological Sciences* 109:106–112.
- DeWitt, J.C., W.C. Williams, J. Creech, and R.W. Luebke. 2015. Suppression of antigen-specific antibody responses in mice exposed to perfluorooctanoic acid: Role of PPAR α and T- and B-cell targeting. *Journal of Immunotoxicology* 13(1):38–45.
- Donauer, S., A. Chen, Y. Xu, A.M. Calafat, A. Sjodin, and K. Yolton. 2015. Prenatal exposure to polybrominated diphenyl ethers and polyfluoroalkyl chemicals and infant neurobehavior. *The Journal of Pediatrics* 166(3):736–742.
- Dong, G.-H., K.-Y. Tung, C.-H. Tsai, M.-M. Liu, D. Wang, W. Liu, Y.-H. Jin, W.S. Hsieh, Y.L. Lee, and P.-C. Chen. 2013. Serum polyfluoroalkyl concentrations, asthma outcomes, and immunological markers in a case-control study of Taiwanese children. *Environmental Health Perspectives* 121:507–513.
- DuPont (Haskell Laboratory). 2003. *Epidemiology Surveillance Report: Cancer Incidence for Washington Works Site 1959-2001*. U.S. Environmental Protection Agency Administrative Record 226-1307-6.
- EFSA (European Food Safety Authority). 2008. Opinion of the scientific panel on contaminants in the food chain on perfluorooctane sulfonate (PFOS) and perfluorooctanoic acid (PFOA) and their salts. *EFSA Journal* 653:1–131.
- Elcombe, C.R., B.M. Elcombe, J.R. Foster, D.G. Farrar, R. Jung, S-C. Chang, G.L. Kennedy, and J.L. Butenhoff. 2010. Hepatocellular hypertrophy and cell proliferation in Sprague-Dawley rats following dietary exposure to ammonium perfluorooctanoate occurs through increased activation of the xenosensor nuclear receptors PPAR α and CAR/PXR. *Archives of Toxicology* 69:244–257.

- Emmett, E.A., H. Zhang, F.S. Shofer, D. Freeman, N.V. Rodway, C. Desai, and L.M. Shaw. 2006. Community exposure to perfluorooctanoate: relationships between serum concentrations and certain health parameters. *Journal of Occupational Medicine* 48:771–779.
- Eriksen, K.T., M. Sørensen, J.K. McLaughlin, L. Lipworth, A. Tjønneland, K. Overvad, and O. Raaschou-Nielsen. 2009. Perfluorooctanoate and perfluorooctanesulfonate plasma levels and risk of cancer in the general Danish population. *Journal of the National Cancer Institute* 101:605–609.
- Eriksen, K.T., O. Raaschou-Nielsen, M. Sørensen, M. Roursgaard, S. Loft, and P. Møller. 2010. Genotoxic potential of the perfluorinated chemicals PFOA, PFOS, PFBS, PFNA, and PFHxA in human HepG2 cells. *Mutation Research/Genetic Toxicology and Environmental Mutagenesis* 700(1-2):39–43.
- Eriksen, K.T., O. Raaschou-Nielsen, J.K. McLaughlin, L. Lipworth, A. Tjønneland, K. Overvad, and M. Sørensen. 2013. Association between plasma PFOA and PFOS levels and total cholesterol in a middle-aged Danish population. *PLoS ONE* 8:e56969.
- Erol, E., L.S. Kumar, G.W. Cline, G.I. Shulman, D.P. Kelly, and B. Binas. 2003. Liver fatty acid-binding protein is required for high rates of hepatic fatty acid oxidation but not for the action of PPAR α in fasting mice. *Federation of the American Societies for Experimental Biology Journal* 18:347–349.
- Fairley, K.J., R. Purdy, S. Kearns, S.E. Anderson, and B.J. Meade. 2007. Exposure to the immunosuppressant, perfluorooctanoic acid, enhances the murine IgE and airway hyperreactivity response to ovalbumin. *Toxicological Sciences* 97:375–383.
- Fàbrega, F., V. Kumar, M. Schuhmacher, J.L. Domingo, and M. Nadal. 2014. PBPK modeling for PFOS and PFOA: validation with human experimental data. *Toxicology Letters* 230:244–251.
- Fasano, W.J., G.L. Kennedy, B. Szostek, D.G. Farrar, R.J. Ward, L. Haroun, and P.M. Hinderliter. 2005. Penetration of ammonium perfluorooctanoate through rat and human skin in vitro. *Drug & Chemical Toxicology* 28:79–90.
- Fei, C., J.K. McLaughlin, R.E. Tarone, and J. Olsen. 2007. Perfluorinated chemicals and fetal growth: a study within the Danish national birth cohort. *Environmental Health Perspectives* 115:1677–1682.
- Fei, C., J.K. McLaughlin, R.E. Tarone, and J. Olsen. 2008a. Fetal growth indicators and perfluorinated chemicals: a study in the Danish National Birth Cohort. *American Journal of Epidemiology* 168:66–72.
- Fei, C., J.K. McLaughlin, L. Lipworth, and J. Olsen. 2008b. Prenatal exposure to perfluorooctanoate (PFOA) and perfluorooctanesulfonate (PFOS) and maternally reported developmental milestones in infancy. *Environmental Health Perspectives* 116:1391–1395.
- Fei, C., J.K. McLaughlin, L. Lipworth, and J. Olsen. 2009. Maternal levels of perfluorinated chemicals and subfecundity. *Human Reproduction* 24:1200–1205.

- Fei, C., J.K. McLaughlin, L. Lipworth, and J. Olsen. 2010a. Prenatal exposure to PFOA and PFOS and risk of hospitalization for infectious diseases in early childhood. *Environmental Research* 110(8):773–777.
- Fei, C., J.K. McLaughlin, L. Lipworth, and J. Olsen. 2010b. Maternal concentrations of perfluorooctanesulfate (PFOA) and perfluorooctanoate (PFOA) and duration of breastfeeding. *Scandinavian Journal of Work, Environment & Health* 36:413–421.
- Fei, C., and J. Olsen. 2011. Prenatal exposure to perfluorinated chemicals and behavioral or coordination problems at age 7. *Environmental Health Perspectives* 119:573–578.
- Fenton, S.E. 2015. A special issue dedicated to a complex tissue. *Reproductive Toxicology* (54):1–5.
- Fenton, S.E., J.L. Reiner, S.F. Nakayama, A.D. Delinsky, J.P. Stanko, E.P. Hines, S.S. White, A.B. Lindstrom, M.J. Strynar, and S.E. Petropoulou. 2009. Analysis of PFOA in dosed CD-1 mice. Part 2: Disposition of PFOA in tissues and fluids from pregnant and lactating mice and their pups. *Reproductive Toxicology* 27:365–372.
- Fielding, C.J. 2000. Lipoprotein synthesis, transport, and metabolism. Chapter 14 in *Biochemical and Physiological Aspects of Human Nutrition*, ed. M.H. Stipanuk, W.B. Saunders Company, p. 351–364. Philadelphia, PA.
- Filgo, A.J., E.M. Quist, M.J. Hoenerhoff, A.E. Brix, G.E. Kissling, and S.E. Fenton. 2015. Perfluorooctanoic acid (PFOA)-induced liver lesions in two strains of mice following developmental exposures: PPAR α is not required. *Toxicologic Pathology* 45:558–568.
- Fisher, M., T.E. Arbuckle, M. Wade, and D.A. Haines. 2013. Do perfluoroalkyl substances affect metabolic function and plasma lipids?—Analysis of the 2007–2009, Canadian Health Measures Survey (CHMS) Cycle 1. *Environmental Research* 121:95–103.
- Fitz-Simon, N., T. Fletcher, M.I. Luster, K. Steenland, A.M. Calafat, K. Kato, and B. Armstrong. 2013. Reductions in serum lipids with a 4-year decline in serum perfluorooctanoic acid and perfluorooctanesulfonic acid. *Epidemiology* 24:569–576.
- Fletcher, T., T.S. Galloway, D. Melzer, P. Holcroft, R. Cipelli, L.C. Pilling, D. Mondal, M. Luster, and L.W. Harries. 2013. Associations between PFOA, PFOS and changes in the expression of genes involved in cholesterol metabolism in humans. *Environment International* 57-58:2–10.
- Frame, S.R., and E.E. McConnell. 2003. *Review of Proliferative Lesions of the Exocrine Pancreas in Two Chronic Studies in Rats with Ammonium Perfluorooctanoate*. DuPont-13788.
- Freire, P., J.M. Pérez Martin, O. Herrero, A. Peropadre, E. de la Peña, and M.J. Hazen. 2008. *In vitro* assessment of the cytotoxic and mutagenic potential of perfluorooctanoic acid. *Toxicology In Vitro* 22:1228–1233.
- Frisbee, S., A. Shankar, S.S. Knox, K. Steenland, D.A. Savitz, T. Fletcher, and A.M. Ducatman. 2010. Perfluorooctanoic acid, perfluorooctanesulfonate, and serum lipids in children and adolescents. *Archives of Pediatrics and Adolescent Medicine* 164:860–869.

- Fu, Y., T. Wang, Q. Fu, P. Wang, and Y. Lu. 2014. Associations between serum concentrations of perfluoroalkyl acids and serum lipid levels in a Chinese population. *Ecotoxicology and Environmental Safety* 106:246–52.
- Gabriel, K. 1976a. *Acute Oral Toxicity – Rats*. Biosearch, Inc., September 16, 1976. U.S. Environmental Protection Agency Administrative Record 226-0425.
- Gabriel, K. 1976b. *Primary Eye Irritation Study in Rabbits*. Biosearch, Inc., September 16, 1976. U.S. Environmental Protection Agency Administrative Record 226-0426.
- Gabriel, K. 1976c. *Primary Eye Irritation Study in Rabbits*. Biosearch, Inc., March 4, 1976. U.S. Environmental Protection Agency Administrative Record 226-0422.
- Gabriel, K. 1976d. *Primary Skin Irritation Study in Rabbits*. Biosearch, Inc., March 4, 1976. U.S. Environmental Protection Agency Administrative Record 226-0423.
- Gallo, V., G. Leonardi, B. Genser, M.-J. Lopez-Espinosa, S.J. Frisbee, L. Karlsson, A.M. Ducatman, and T. Fletcher. 2012. Serum perfluorooctanoate (PFOA) and perfluorooctane sulfonate (PFOS) concentrations and liver function biomarkers in a population with elevated PFOA exposure. *Environmental Health Perspectives* 120(5):655–660.
- Galloway, T.S., T. Fletcher, O.J. Thomas, B.P. Lee, L.C. Pilling, and L.W. Harries. 2015. PFOA and PFOS are associated with reduced expression of the parathyroid hormone 2 receptor (PTH2R) gene in women. *Chemosphere* 120:555–562.
- Garrett, R.H., and C.M. Grisham. 1999. *Biochemistry*. Saunders college Publishing. Fort Worth, TX.
- Garry, V.F., and R.L. Nelson. 1981. *An Assay of Cell Transformation and Cytotoxicity in C3H10T $\frac{1}{2}$ Clonal Cell Line for the Test Chemical T-2942 CoC*. Stone Research Laboratories, Minneapolis, MN, March 4, 1981. U.S. Environmental Protection Agency Administrative Record 226-0428.
- Gazouli, M., Z-X. Yao, N. Boujrad, J.C. Corton, M. Culty, and V. Papadopoulos. 2002. Effect of peroxisome proliferators on Leydig cell peripheral-type benzodiazepine receptor gene expression, hormone-stimulated cholesterol transport, and steroidogenesis: Role of the peroxisome proliferator-activator receptor α . *Endocrinology* 143:2571–2583.
- Geiger, S.D., J. Xiao, A. Ducatmen, S. Frisbee, K. Innes, and A. Shankar. 2014a. The association between PFOA, PFOS and serum lipid levels in adolescents. *Chemosphere* 98:78–83.
- Geiger, S.D., J. Xiao, and A. Shankar. 2014b. No association between perfluoroalkyl chemicals and hypertension in children. *Integrated Blood Pressure Control* 7:1–7.
- Gelman, A., J.B. Carlin, H.S. Stern, and D.B. Rubin. 2004. *Bayesian Data Analysis*. 2nd ed. Chapman and Hall/CRC, Boca Raton, FL.
- Genuis, S.J., D. Birkholz, M. Ralitsch, and N. Thibault. 2010. Human detoxification of perfluorinated compounds. *Public Health* 124:367–375.

- Ghisari, M., H. Eiberg, M. Long, and E.C. Bonfeld-Jørgensen. 2014. Polymorphisms in phase I and phase II genes and breast cancer risk and relations to persistent organic pollutant exposure: a case-control study in Inuit women. *Environmental Health* 13(1):19
- Gibson, S.J., and J.D. Johnson. 1979. *Absorption of FC-143-14C in Rats After a Single Oral Dose*. Riker Laboratories, Inc., Subsidiary of 3M, St. Paul, MN.
- Gibson, S.J., and J.D. Johnson. 1983. *Extent and Route of Excretion of Total Carbon-14 in Pregnant Rats After a Single Oral Dose of Ammonium 14 C-perfluorooctanoate*. Riker Laboratories, Inc., Subsidiary of 3M, St. Paul, MN.
- Gilliland, F.D., and J.S. Mandel. 1993. Mortality among employees of a perfluorooctanoic acid production plant. *Journal of Occupational Medicine* 35:950–954.
- Glaza, S. 1995. *Acute Dermal Toxicity Study of T-6342 in Rabbits*. Corning Hazelton, Inc., Madison, WI. Project ID: HWI 50800374. 3M Company. St. Paul, MN. U.S. Environmental Protection Agency Administrative Record 226-0427.
- Glaza, S.M. 1997. Acute oral toxicity study of T-6669 in rats. Corning Hazleton Inc., Study No. CHW 61001760, January 10, 1997. U.S. Environmental Protection Agency Administrative Record 226-0420.
- Goldenthal, E.I. 1978. *Final Report, Ninety Day Subacute Rhesus Monkey Toxicity Study*. International Research and Development Corporation, Study No. 137-090, November 10, 1978. U.S. Environmental Protection Agency Administrative Record 226-0447.
- Goodrich, A.G., and H.S. Sul. 2000. Lipid metabolism-synthesis and oxidation. Chapter 13 in *Biochemical and Physiological Aspects of Human Nutrition*, ed. M.H. Stipanuk, W.B. Saunders, p. 305–337. Philadelphia, PA.
- Governini, L., C. Guerranti, V. De Leo, L. Boschi, A. Luddi, M. Gori, R. Orvieto, and P. Piomboni. 2015. Chromosomal aneuploidies and DNA fragmentation of human spermatozoa from patients exposed to perfluorinated compounds. *Andrologia* 47:1012–1019.
- Grandjean, P., E.W. Andersen, E. Budtz-Jørgensen, F. Nielsen, K. Mølbak, P. Weihe, and C. Heilmann. 2012. Serum vaccine antibody concentrations in children exposed to perfluorinated compounds. *Journal of the American Medical Association* 307:391–397.
- Grandjean, P., and R. Clapp. 2015. Perfluorinated Alkyl Substances Emerging Insights Into Health Risks. *NEW SOLUTIONS: A Journal of Environmental and Occupational Health Policy* 25(2):147–163.
- Granum, B., L.S. Haug, E. Namork, S.B. Stølevik, C. Thomsen, I.S. Aaberge, H. van Loveren, M. Løvik, and U.C. Nygaard. 2013. Pre-natal exposure to perfluoroalkyl substances may be associated with altered vaccine antibody levels and immune-related health outcomes in early childhood. *Journal of Immunotoxicology* 10:373–379.

- Hall, A.P., C.R. Elcombe, J.R. Foster, T. Harada, W. Kaufmann, A. Knippel, K. Küttler, D.E. Malarkey, R.R. Maronpot, A. Nishikawa, T. Nolte, A. Schulte, V. Strauss, and M.J. York. 2012. Liver hypertrophy: A review of adaptive (adverse and non-adverse) changes – conclusions from the 3rd International ESTP Expert Workshop. *Toxicologic Pathology* 40:971–994.
- Halldorsson, T.I., D. Rytter, L.S. Haug, B.H. Bech, I. Danielsen, G. Becher, T.B. Henriksen, and S.F. Olsen. 2012. Prenatal exposure to perfluorooctanoate and risk of overweight at 20 years of age: A prospective cohort study. *Environmental Health Perspectives* 120:668–673.
- Hamm, M., N.M. Cherry, E. Chan, J. Martin, and I. Burstyn. 2010. Maternal exposure to perfluorinated acids and fetal growth. *Journal of Exposure Science and Environmental Epidemiology* 20(7):589–597.
- Han, H., T.A. Snow, R.A. Kemper, and G.W. Jepson. 2003. Binding of perfluorooctanoic acid to rat and human plasma proteins. *Chemical Research in Toxicology* 16:775–781.
- Han, X. 2003. *Ammonium Perfluorooctanoate: Age Effect on the Plasma Concentration in Post-Weaning Rats Following Oral Gavage*. Haskell Laboratory for Health and Environmental Sciences. Study No. Dupont-13267, December 15, 2003. U.S. Environmental Protection Agency Administrative Record 226-1553.
- Han, X., R.A. Kemper, and G.W. Jepson. 2005. Subcellular distribution and protein binding of perfluorooctanoic acid in rat liver and kidney. *Drug and Chemical Toxicology* 28:197–209.
- Hanhijarvi, H., R.H. Ophaug, and L. Singer. 1982. The sex-related difference in perfluorooctanoate excretion in the rat. *Proceedings of the Society for Experimental Biology and Medicine* 171(1):50–55.
- Hanhijarvi, H., M. Ylinen, A. Kojo, and V.M. Kosma. 1987. Elimination and toxicity of perfluorooctanoic acid during subchronic administration in the Wistar rat. *Pharmacology & Toxicology* 61(1):66–68.
- Harada, K., K. Inoue, A. Morikawa, T. Yoshinaga, N. Saito, and A. Koizumi. 2005. Renal clearance of perfluorooctane sulfonate and perfluorooctanoate in humans and their species-specific excretion. *Environmental Research* 99:253–261.
- Hardell, E., A. Kärman, B. van Bavel, J. Boa, M. Carlberg, and L. Hardell. 2014. Case-control study on perfluorinated alkyl acids (PFAAs) and the risk of prostate cancer. *Environment International* 63:35–39.
- Hardisty, J.F. 2005. *PWG Report: Pathology Peer Review and Pathology Working Group Review of Mammary Glands from a Chronic Feeding Study in Rats with PFOA*. Experimental Pathology Laboratories, Inc., Research Triangle Park, NC. June 17, 2005.
- Hardisty, J.F., G.A. Willson, W.R. Brown, E.E. McConnell, S.R. Frame, D.W. Gaylor, G.L. Kennedy, and J.L. Butenhoff. 2010. Pathology working group review and evaluation of proliferative lesions of mammary gland tissues in female rats fed ammonium perfluorooctanoate (APFO) in the diet for 2 years. *Drug and Chemical Toxicology* 33:131–137.

- Harkness, J.E., and J.E. Wagner. 1983. *The Biology and Medicine of Rabbits and Rodents*. 2nd ed. Lea & Febiger, Philadelphia, PA.
- Heidelberger, P., and P.D. Welch. 1983. Simulation run length control in the presence of an initial transient. *Operations Research* 31:1109–1144.
- Hekster, F.M., R.W. Laane, and P. de Voogt. 2003. Environmental and toxicity effects of perfluoroalkylated substances. *Reviews of Environmental Contamination and Toxicology* 179:99–121.
- Higgins, C., and R. Luthy. 2006. Sorption of Perfluorinated Surfactants on Sediments. *Environmental Science & Technology* 40(23):7251–7256.
- Hinderliter, P.M. 2003. *Perfluorooctanoic Acid: Relationship Between Repeated Inhalation Exposures and Plasma PFOA Concentration in the Rat*. Haskell Laboratory for Health and Environmental Sciences. Study No. DuPont-12944. November 5, 2003.
- Hinderliter, P.M. 2004. *Ammonium Perfluorooctanoate: Age Effect on the PFOA Plasma Concentration in Post-Weaning Rats Following Oral Gavage*. E.I. du Pont de Nemours and Company. Laboratory Project ID: Dupont-15302. December 2, 2004.
- Hinderliter, P.M., E. Mylchreest, S.A. Gannon, J.L. Butenhoff, and G.L. Kennedy, Jr. 2005. Perfluorooctanoate: Placental and lactational transport pharmacokinetics in rats. *Toxicology* 211:139–148.
- Hinderliter, P.M., X. Han, G.L. Kennedy, Jr., and J.L. Butenhoff. 2006a. Age effect on perfluorooctanoate (PFOA) plasma concentration in post-weaning rats following oral gavage with ammonium perfluorooctanoate (APFO). *Toxicology* 225:195–203.
- Hinderliter, P.M., M.P. DeLorme, and J.L. Butenhoff. 2006b. Perfluorooctanoic acid: Relationship between repeated inhalation exposures and plasma PFOA concentration in the rat. *Toxicology* 222:80–85.
- Hines, E.P., S.S. White, J.P. Stanko, E.A. Gibbs-Flournoy, C. Lau, and S.E. Fenton. 2009. Phenotypic dichotomy following developmental exposure to perfluorooctanoic acid (PFOA) in female CD-1 mice: Low doses induce elevated serum leptin and insulin, and overweight in mid-life. *Molecular and Cellular Endocrinology* 304:97–105.
- Hoffman, K., T.F. Webster, M.G. Weisskopf, J. Weinberg, and V.M. Vieira. 2010. Exposure to polyfluoroalkyl chemicals and attention deficit hyperactivity disorder in U.S. children ages 12-15 years. *Environmental Health Perspectives* 118:1732–1767.
- Hölzer, J., T. Goen, K. Rauchfuss, M. Kraft, J. Angerer, P. Kleeschulte, and M. Wilhelm. 2008. Biomonitoring of perfluorinated compounds in children and adults exposed to perfluorooctanoate-contaminated drinking water. *Environmental Health Perspectives* 116:651–657.
- Høyer, B.B., C.H. Ramlau-Hansen, C. Obel, H.S. Pedersen, A. Hernik, V. Ogniev, B.A.G. Jönsson, C.H. Lindh, L. Rylander, A. Rignell-Hydbom, J.P. Bonde and G. Toft. 2015a. Pregnancy serum concentrations of perfluorinated alkyl substances and offspring behavior and motor development at age 5-9 years – a prospective study. *Environmental Health* 14:2.

- Høyer, B.B., C.H. Ramlau-Hansen, M. Vrijheid, D. Valvi, H.S. Pedersen, V. Zvezdai, B.A.G. Jönsson, C.H. Lindh, J.P. Bonde, and G. Toft. 2015b. Anthropometry in 5- to 9-year old Greenlandic and Ukrainian children in relation to prenatal exposure to perfluorinated alkyl substances. *Environmental Health Perspectives* 123:841–846.
- HSDB (Hazardous Substances Data Base). 2006. U.S. National Library of Medicine, Bethesda, MD. Accessed May 2016. <http://toxnet.nlm.nih.gov/>.
- HSDB (Hazardous Substances Data Bank). 2012. U.S. National Library of Medicine, Bethesda, MD. Accessed May 2016. <http://toxnet.nlm.nih.gov/cgi-bin/sis/htmlgen?HSDB>.
- Hu, X., and D. Hu. 2009. Effects of perfluorooctanoate and perfluorooctane sulfate exposure on hepatoma Hep G2 cells. *Archives of Toxicology* 83:851–861.
- Humblet, O., L.G. Diaz-Ramirez, J.R. Balmes, S.M. Pinney, and R.A. Hiatt. 2014. Perfluoroalkyl chemicals and asthma among children 12-19 years of age: NHANES (1999-2008). *Environmental Health Perspectives* 122:1129–1133.
- Hundley, S.G., A.M. Sarrif, and G.L. Kennedy Jr. 2006. Absorption, distribution, and excretion of ammonium perfluorooctanoate (APFO) after oral administration to various species. *Drug & Chemical Toxicology* 29(2): 137–145.
- Ikeda, T., K. Aiba, K. Fukuda, and M. Tanaka. 1985. The induction of peroxisome proliferation in rat liver by perfluorinated fatty acids, metabolically inert derivatives of fatty acids. *Journal of Biochemistry* 98:475–482.
- Innes, K.E., J.H. Wimsatt, S. Frisbee, and A.M. Ducatman. 2014. Inverse association of colorectal cancer prevalence to serum levels of perfluorooctane sulfonate (PFOS) and perfluorooctanoate (PFOA) in a large Appalachian population. *BMC Cancer* 14:45.
- Ito, S., and J. Alcorn. 2003. Xenobiotic transporter expression and function in the human mammary gland. *Advanced Drug Delivery Reviews* 55:653–665.
- Jain, R.B. 2014. Contribution of diet and other factors to the levels of selected polyfluorinated compounds: Data from NHANES 2003-2008. *International Journal of Hygiene and Environmental Health* 217:52–61.
- Jain, R.B. 2015. Estimation of the total concentration of perfluoroalkyl acids (PFAA) in human serum: Data from NHANES 2005–2012. *Chemosphere* 134:387–394.
- Joensen, U.N., R. Bossi, H. Leffers, A.A. Jensen, N.E. Skakkebak, and N. Jørgensen. 2009. Do perfluoroalkyl compounds impair human semen quality? *Environmental Health Perspectives* 117:923–927.
- Joensen, U.N., B. Veyrand, J.P. Antignac, M.B. Jensen, J.H. Petersen, P. Marchand, N.E. Skakkebak, A.M. Andersson, B. Le Bizec, and N. Jørgensen. 2013. PFOS (perfluorooctanesulfonate) in serum is negatively associated with testosterone levels, but not with semen quality, in healthy men. *Human Reproduction* 28(3):599–608.

- Johansson, N., A. Fredriksson, and P. Eriksson. 2008. Neonatal exposure to perfluorooctane sulfonate (PFOS) and perfluorooctanoic acid (PFOA) causes neurobehavioural defects in adult mice. *NeuroToxicology* 29:160–169.
- Johansson, N., P. Eriksson, and H. Viberg. 2009. Neonatal exposure to PFOS and PFOA in mice results in changes in proteins which are important for neuronal growth and synaptogenesis in the developing brain. *Toxicological Sciences* 108:412–418.
- Johnson, P.I., P. Sutton, D.S. Atchley, E. Koustas, J. Lam, S. Sen, K.A. Robinson, D.A. Axelrad, and T.J. Woodruff. 2014. The Navigation Guide – evidence-based medicine meets environmental health: Systematic review of human evidence for PFOA effects on fetal growth. *Environmental Health Perspectives* 122:1028–1039.
- Kaiser M.A., B.S. Larsen, C-PC. Kao, and R.C. Buck. 2005. Vapor pressures of perfluorooctanoic, -nonanoic, -decanoic, undecanoic, and dodecanoic acids. *Journal of Chemical & Engineering Data* 50(6):1841–1843.
- Karnes, C., A. Winqvist, and K. Steenland. 2014. Incidence of type II diabetes in a cohort with substantial exposure to perfluorooctanoic acid. *Environmental Research* 128:78–83.
- Karns, M.E., and W.E. Fayerweather. 1991. *A Case-Control Study of Leukemia at the Washington Works Site*. Final Report. Dupont Company. December 31, 1991. U.S. Environmental Protection Agency Administrative Record 226-1308-2.
- Kärman, A., J.L. Domingo, X. Llebaria, M. Nadal, E. Bigas, B. van Bavel, and G. Lindström. 2009. Biomonitoring perfluorinated compounds in Catalonia, Spain: Concentrations and trends in human liver and milk samples. *Environmental Science and Pollution Research* 17(3):750–758.
- Kato, J., A.M. Calafat, L-Y. Wong, A.A. Wanigatunga, S.P. Caudill, and L.L. Needham. 2009. Polyfluoroalkyl compounds in pooled sera from children participating in the National Health and Nutrition Examination Survey 2001-2002. *Environmental Science & Technology* 43:2641–2647.
- Kato, K., L.Y. Wong, A. Chen, C. Dunbar, G.M. Webster, B.P. Lanphear, and A.M. Calafat. 2014. Changes in serum concentrations of maternal poly-and perfluoroalkyl substances over the course of pregnancy and predictors of exposure in a multiethnic cohort of Cincinnati, Ohio pregnant women during 2003–2006. *Environmental Science & Technology* 48(16):9600–9608.
- Kauck, E.A., and A.R. Diesslin. 1951. Some properties of perfluorocarboxylic acids. *Industrial & Engineering Chemistry Research* 43(10):2332–2334.
- Keller, B.J., D.S. Marsman, J.A. Popp, and R.G. Thurman. 1992. Several nongenotoxic carcinogens uncouple mitochondrial oxidative phosphorylation. *Biochimica et Biophysica Acta* 1102(2):237–244.
- Kemper, R.A. 2003. *Perfluorooctanoic Acid: Toxicokinetics in the Rat*. Laboratory Project ID: Dupont-7473. Haskell Laboratory for Health and Environmental Sciences, E.I. du Pont de Nemours and Company. April 2, 2003. U.S. Environmental Protection Agency Administrative Record 226-1499.

- Kennedy, G.L., Jr. 1985. Dermal toxicity of ammonium perfluorooctanoate. *Toxicology and Applied Pharmacology* 81(2):348–355.
- Kennedy, G.L., G.T. Hall, M.R. Brittelli, J.R. Barnes, and H.C. Chen. 1986. Inhalation toxicity of ammonium perfluorooctanoate. *Food and Chemical Toxicology* 24:1325–1329.
- Kennedy, G.L. 1987. Increase in mouse liver weight following feeding of ammonium perfluorooctanoate and related fluorochemicals. *Toxicology Letters* 39(2):295–300.
- Kennedy, G.L., Jr., J.L. Butenhoff, G.W. Olsen, J.C. O’Conner, A.M. Seacat, R.G. Perkins, L.B. Biegel, S.R. Murphy, and D.G. Farrar. 2004. The toxicology of perfluorooctanoate. *Critical Reviews in Toxicology* 34:351–384.
- Kerger, B.D., T.L. Copeland, and A.P. DeCaprio. 2011. Tenuous dose-response correlations for common disease states: case study of cholesterol and perfluorooctanoate/sulfonate (PFOA/PFOS) in the C8 Health Project. *Drug and Chemical Toxicology* 34(4):396–404.
- Kerstner-Wood, C., L. Coward, and G. Gorman. 2003. *Protein Binding of Perfluorohexane Sulfonate, Perfluorooctane Sulfonate and Perfluorooctanoate to Plasma (Human, Rat, and Monkey), and Various Human-Derived Plasma Protein Fractions*. Southern Research Institute. Study ID 9921.7. U.S. Environmental Protection Agency Administrative Record 226-1354.
- Kim, R.B. 2003. Organic anion-transporting polypeptide (OATP) transporter family and drug disposition. *European Journal of Clinical Investigation* 33:1–5 S2.
- Kirk-Othmer. 1994. *Encyclopedia of Chemical Technology*. 4th ed. Volumes 1: 1991-Present. John Wiley and Sons, New York, NY. p. V11:551.
- Kjeldsen, L.S., and E.C. Bonefeld-Jørgensen. 2013. Perfluorinated compounds affect the function of sex hormone receptors. *Environmental Science and Pollution Research* 20(11):8031–8044.
- Klaassen, C.D., and H. Lu. 2008. Xenobiotic transporters: Ascribing function from gene knockout and mutation studies. *Toxicological Sciences* 101:186–196.
- Klaassen, C.D., and L.M. Aleksunes. 2010. Xenobiotic, bile acid, and cholesterol transporters: Function and regulation. *Pharmacological Reviews* 62:1–96.
- Klaunig, J.E., M. A. Babich, L.P. Baetcke, J.C. Cook, J.C. Corton, R.M. David, J.G. DeLuca, D.Y. Lai, R.H. McKee, J.M. Peters, R.A. Roberts, and P.A. Fenner-Crisp. 2003. PPAR α agonist-induced rodent tumors: modes of action and human relevance. *Critical Reviews in Toxicology* 33:655–780.
- Klaunig, J.E., B.A. Hocevar, and L.M. Kamendulis. 2012. Mode of action analysis of perfluorooctanoic acid (PFOA) tumorigenicity and human relevance. *Reproductive Toxicology* 33:410–418.
- Knox, S.S., T. Jackson, B. Javins, S.J. Frisbee, A. Shankar, and A.M. Ducatman. 2011. Implications of early menopause in women exposed to perfluorocarbons. *Journal of Endocrinology and Metabolism* 96:1–7.

- Koustaş, E., J. Lam, P. Sutton, P.I. Johnson, D.S. Atchley, S. Sen, K.A. Robinson, D.A. Axelrad, and T.J. Woodruff. 2014. The Navigation Guide – evidence-based medicine meets environmental health: systematic review of nonhuman evidence for PFOA effects on fetal growth. *Environmental Health Perspectives* 122:1015–1027.
- Kristensen, S.L., C.H. Ramlau-Hansen, E. Ernst, S.F. Olsen, J.P. Bonde, A. Vested, T.I. Halldorsson, G. Becher, L.S. Haug, and G. Toft. 2013. Long-term effects of prenatal exposure to perfluoroalkyl substances on female reproduction. *Human Reproduction* 0:1–12.
- Kudo, N., M. Katakura, Y. Sato, and Y. Kawashima. 2002. Sex hormone-regulated renal transport of perfluorooctanoic acid. *Chemico-Biological Interactions* 139:301–316.
- Kudo, N., A. Sakai, A. Mitsumoto, Y. Hibino, T. Tsuda, and Y. Kawashima. 2007. Tissue distribution and hepatic subcellular distribution of perfluorooctanoic acid at low doses are different from those at high doses. *Biological and Pharmaceutical Bulletin* 30:1535–1540.
- Kusuhara H., and Y. Sugiyama. 2009. In vitro-in vivo extrapolation of transporter mediated clearance in the liver and kidney. *Drug Metabolism and Pharmacokinetics* 24:37–52.
- Lau, C., J.R. Thibodeaux, R.G. Hanson, M.G. Narotsky, J.M. Rogers, A.B. Lindstrom, and M.J. Strynar. 2006. Effects of perfluorooctanoic acid exposure during pregnancy in the mouse. *Toxicological Sciences* 90:510–518.
- Launay-Vacher, V., H. Izzedine, S. Karie, J.S. Hulot, A. Baumelou, and G. Deray. 2006. Renal tubular drug transporters. *Nephron Physiology* 103:97–106.
- Lawlor, T.E. 1995. *Mutagenicity Test with T-6342 in the Salmonella-Escherichia coli/Mammalian-Microsome Reverse Mutation Assay*. Laboratory Number: 17073-0-409. Corning Hazleton Inc., Vienna, VA. 3M Company, St. Paul, MN. U.S. Environmental Protection Agency Administrative Record 226-0436.
- Lawlor, T.E. 1996. *Mutagenicity Test with T-6564 in the Salmonella-Escherichia coli/Mammalian-Microsome Reverse Mutation Assay with a Confirmatory Assay*. Corning Hazleton Inc. Final Report. CHV Study No: 17750-0-409R. September 13, 1996. U.S. Environmental Protection Agency Administrative Record 226-0432.
- Leonard, R.C., K.H. Kreckmann, C.J. Sakr, and J.M. Symons. 2008. Retrospective cohort mortality study of workers in a polymer production plant including a reference population of regional workers. *Annals of Epidemiology* 18:15–22.
- Lewis, R.J., Sr., ed. 2004. *Sax's Dangerous Properties of Industrial Materials*. 11th ed. Wiley-Interscience, Wiley & Sons, Inc., Hoboken, NJ. p.V3:2860.
- Li, Y., D.H. Ramdhan, H. Naito, N. Yamagishi, Y. Ito, Y. Hayashi, Y. Yanagiba, A. Okamura, H. Tamada, F.J. Gonzalez, and T. Nakajima. 2011. Ammonium perfluorooctanoate may cause testosterone reduction by adversely affecting testis in relation to PPAR α . *Toxicology Letters* 205:265–272.

- Liao, C., T. Wang, L. Cui, Q. Zhou, S. Duan, and G. Jiang. 2009a. Changes in synaptic transmission, calcium current, and neurite growth by perfluorinated compounds are dependent on the chain length and functional group. *Environmental Science & Technology* 43:2099–2104.
- Liao, C., T. Wang, L. Cui, Q. Zhou, S. Duan, and G. Jiang. 2009b. Supporting information: Changes in synaptic transmission, calcium current, and neurite growth by perfluorinated compounds are dependent on the chain length and functional group. *Environmental Science & Technology* 43:2099–2104.
- Lide, D.R. 2007. *CRC Handbook of Chemistry and Physics* 88TH Edition 2007-2008. CRC Press, Taylor & Francis, Boca Raton, FL. p. 3–412.
- Liew, Z., B. Ritz, E.C. Bonefeld-Jørgensen, T.B. Henriksen, E.A. Nohr, B.H. Bech, C. Fei, R. Bossi, O.S. von Ehrenstein, E. Streja, P. Uldall, and J. Olsen. 2014. Prenatal exposure to perfluoroalkyl substances and the risk of congenital cerebral palsy in children. *American Journal of Epidemiology* 180:574–581.
- Lin, C.-Y., Y.-C. Lin, P.-C. Chen, and L.-Y. Lin. 2009. Association among serum perfluoroalkyl chemicals, glucose homeostasis, and metabolic syndrome in adolescents and adults. *Diabetes Care* 32:702–707.
- Lin, C.-Y., L.-Y. Lin, C.-K. Chiang, W.-J. Wang, Y.-N. Su, K.-Y. Hung, and P.-C. Chen. 2010. Investigation of the associations between low-dose serum perfluorinated chemicals and liver enzymes in US adults. *American Journal of Gastroenterology* 105:1354–1363.
- Lin, C.-Y., L.-L. Wen, L.-Y. Lin, T.-W. Wen, G.-W. Lien, S.H. Hsu, K. L. Chien, C. C. Liao, F. C. Sung, P. C. Chen, and T. C. Su. 2013. The associations between serum perfluorinated chemicals and thyroid function in adolescents and young adults. *Journal of Hazardous Materials* 244–245:637–644.
- Liu, R.C.M., M.E. Hurtt, J.C. Cook, and L.B. Biegel. 1996. Effect of the peroxisome proliferator, ammonium perfluorooctanoate (C8), on hepatic aromatase activity in adult male Crl:CD BR (CD) rats. *Fundamentals of Applied Toxicology* 30:220–228.
- Liu, W., B. Yang, L. Wu, W. Zou, X. Pan, T. Zou, F. Liu, L. Xia, X. Wan, and D. Zhang. 2015. Involvement of NRF2 in perfluorooctanoic acid-induced testicular damage in male mice. *Biology of Reproduction* 93(2):1–7.
- Loccisano, A.E., J.L. Campbell, M.E. Andersen, and H.J. Clewell. 2011. Evaluation and prediction of pharmacokinetics of PFOA and PFOS in the monkey and human using a PBPK model. *Regulatory Toxicology and Pharmacology* 59:157–175.
- Loccisano, A.E., J.L. Campbell, J.L. Butenhoff, M.E. Andersen, and H.J. Clewell. 2012a. Comparison and evaluation of pharmacokinetics of PFOA and PFOS in the adult rat using a physiologically based pharmacokinetic model. *Reproductive Toxicology* 33:452–467.
- Loccisano, A.E., J.L. Campbell, J.L. Butenhoff, M.E. Andersen, and H.J. Clewell. 2012b. Evaluation of placental and lactational pharmacokinetics of PFOA and PFOS in the pregnant, lactating, fetal and neonatal rat using a physiologically based pharmacokinetic model. *Reproductive Toxicology* 33:468–490.

- Loccisano, A.E., M.P. Longnecker, J.L. Campbell, Jr., M.E. Andersen, and H.J. Clewell. 2013. Development of PBPK models for PFOA and PFOS for human pregnancy and lactation life stages. *Journal of Toxicology and Environmental Health, Part A* 76:25–57.
- Long, Y., Y. Wang, G. Ji, L. Yan F. Hu, and A. Gu. 2013. Neurotoxicity of perfluorooctane sulfonate to hippocampal cells in adult mice. *PloS One* 8(1):e54176.
- Looker, C., M.I. Luster, A.M. Calafat, V.J. Johnson, G.R. Burleson, F.G. Burleson, and T. Fletcher. 2014. Influenza vaccine response in adults exposed to perfluorooctanoate and perfluorooctanesulfonate. *Toxicological Sciences* 138:76–88.
- López-Doval, S., R. Salgado, N. Pereiro, R. Moyano, and A. Lafuente. 2014. Perfluorooctane sulfonate effects on the reproductive axis in adult male rats. *Environmental Research* 134:158–168.
- Lopez-Espinosa, M.-J., T. Fletcher, B. Armstrong, B. Genser, K. Dhatariya, D. Mondal, A. Ducatman, and G. Leonardi. 2011. Association of perfluorooctanoic acid (PFOA) and perfluorooctane sulfonate (PFOS) with age of puberty among children living near a chemical plant. *Environmental Science & Technology* 45(19):8160–816.
- Lopez-Espinosa, M.-J., D. Mondal, B. Armstrong, M.S. Bloom, and T. Fletcher. 2012. Thyroid function and perfluoroalkyl acids in children living near a chemical plant. *Environmental Health Perspectives* 120:1036–1041.
- Lorber, M., and P.P. Egeghy. 2011. Simple intake and pharmacokinetic modeling to characterize exposure of Americans to perfluorooctanoic acid, PFOA. *Environmental Science & Technology* 45:8006–8014.
- Lou, I., J.F. Wambaugh, C. Lau, R.G. Hanson, A.B. Lindstrom, M.J. Strynar, R.D. Zehr, R.W. Setzer, and H.A. Barton. 2009. Modeling single and repeated dose pharmacokinetics of PFOA in mice. *Toxicological Sciences* 107:331–341.
- Loveless, S.E., D. Hoban, G. Sykes, S.R. Frame, and, N.E. Everds. 2008. Evaluation of the immune system in rats and mice administered linear ammonium perfluorooctanoate. *Toxicological Sciences* 105:86–96.
- Lu, Y., B. Luo, J. Li, and J. Dai. 2015. Perfluorooctanoic acid disrupts the blood-testes barrier and activates TNF α /p38 MAPK signaling pathway in vivo and in vitro. *Archives of Toxicology* 90(4):971–983.
- Luebker, D.J., K.J. Hansen, N.M. Bass, J.L. Butenhoff, and A.M. Seacat. 2002. Interactions of fluorochemicals with rat liver fatty acid-binding protein. *Toxicology* 176:175–185.
- Lundin, J.I., B.H. Alexander, G.W. Olsen, and T.R. Church. 2009. Ammonium perfluorooctanoate production and occupational mortality. *Epidemiology* 20:921–928.
- MacManus-Spencer, L.A., M.L. Tse, P.C. Hebert, H.N. Bichel, and R.G. Luthy. 2010. Binding of perfluorocarboxylates to serum albumin: A comparison of analytical methods. *Analytical Chemistry* 82(3):974–981.

- MacNeil, J., N.K. Steenland, A. Shankar, and A. Ducatman. 2009. A cross-sectional analysis of type II diabetes in a community with exposure to perfluorooctanoic acid (PFOA). *Environmental Research* 109:997–1003.
- Macon, M.B., L.R. Villanueva, K. Tatum-Gibbs, R.D. Zehr, M.J. Strynar, J.P. Stanko, S.S. White, L. Helfant, and S.E. Fenton. 2011. Prenatal perfluorooctanoic acid exposure in CD-1 mice: Low dose developmental effects and internal dosimetry. *Toxicological Sciences* 121(1):134–145.
- Maher, J.M., L.M. Aleksunes, M.Z. Dieter, Y. Tanaka, J.M. Peters, J.E. Manautou, and C.D. Klaassen. 2008. Nrf2- and PPAR α - mediated regulation of Mrp transporters after exposure to perfluorooctanoic acid and perfluorodecanoic acid. *Toxicological Sciences* 106:319–328.
- Maisonet, M., M.L. Terrell, M.A. McGeehin, K.Y. Christensen, A. Holmes, A.M. Calafat, and M. Marcus. 2012. Maternal concentration of polyfluoroalkyl compounds during pregnancy and fetal and postnatal growth in British girls. *Environmental Health Perspectives* 120:1432–1437.
- Maisonet, M., S. Näyhä, D.A. Lawlor, and M. Marcus. 2015. Prenatal exposures to perfluoroalkyl acids and serum lipids at ages 7 and 15 in females. *Environment International* 82:49–60.
- Maloney, E.K., and D.J. Waxman. 1999. Trans-activation of PPAR α and PPAR γ by structurally diverse environmental chemicals. *Toxicology & Applied Pharmacology* 161:209–218.
- Mann, P.C., G.A. Boorman, L.O. Lollini, D.N. McMartin, and D.G. Goodman. 1996. Proliferative lesions of the mammary gland in rats. IS-2 in: *Guides for Toxicologic Pathology*. STP/ARP/AFIP, Washington, D.C.
- Mann, P.C., and S.R. Frame. 2004. *FC-143: Two Year Oral Toxicity-Oncogenicity Study in Rats: Peer Review of Ovaries*. DuPont Project ID 15261, June 25, 2004. U.S. Environmental Protection Agency Administrative Record 226.
- Markoe, D.M. 1983. *Primary Skin Irritation Test with T-3371 in Albino Rabbits*. Riker Laboratories, Study No.0883EB0079, July 13, 1983. U.S. Environmental Protection Agency Administrative Record 226-0424.
- Martin, M.T., R.J. Brennan, W. Hu, E. Ayanoglu, C. Lau, H. Ren, C.R. Wood, J.C. Corton, R.J. Kavlock, and D.J. Dix. 2007. Toxicogenomic study of triazole fungicides and perfluoroalkyl acids in rat livers predicts toxicity and categorizes chemicals based on mechanisms of toxicity. *Toxicological Sciences* 97:595–613.
- Medinsky, M.A., and C.D. Klaassen. 1996. Toxicokinetics. In: *Cassarett and Doull's Toxicology The Basic Science of Poisons*. 5th ed. C.D. Klaassen, ed. p. 187–198.
- Melzer, D., N. Rice, M.H. Depledge, W.E. Henley, and T.S. Galloway. 2010. Association between serum perfluorooctanoic acid (PFOA) and thyroid disease in the NHANES study. *Environmental Health Perspectives* 118: 686–692.

- Metrick, M., and A.J. Marias. 1977. *28-Day Oral Toxicity Study with FC-143 in Albino Rats, Final Report*. Industrial Bio-Test Laboratories, Inc. Study No. 8532-10654, 3M Reference No. T-1742CoC, Lot 269, September 29, 1977.
- Miller, R.T., L.A. Scappina, S.M. Long, and J.C. Corton. 2001. Role of thyroid hormones in hepatic effects of peroxisome proliferators. *Toxicologic Pathology* 29:149–155.
- Minata, M., K.H. Harada, A. Kärman, T. Hitomi, M. Hirosawa, F.J. Gonzales, and A. Koizumi. 2010. Role of peroxisome proliferator-activated receptor- α in hepatobiliary injury induced by ammonium perfluorooctanoate in mouse liver. *Industrial Health* 48:96–107.
- Mondal, D., R.H. Weldon, B.G. Armstrong, L.J. Gibson, M.J. Lopez-Espinosa, H.M. Shin, and T. Fletcher. 2014. Breastfeeding: a potential excretion route for mothers and implications for infant exposure to perfluoroalkyl acids. *Environmental Health Perspectives* 122(2):187–192.
- Monroy, R., K. Morrison, K. Two, S. Atkinson, C. Kubwabo, B. Steward, and W.G. Foster. 2008. Serum levels of perfluoroalkyl compounds in human maternal and umbilical cord blood samples. *Environmental Research* 108:56–62.
- Mørck, T.A., F. Nielsen, J.K. Nielsen, V.D. Siersma, P. Grandjean, and L.E. Knudsen. 2015. PFAS concentrations in plasma samples from Danish school children and their mothers. *Chemosphere* 129:203–209.
- Morken, N.-H., G.S. Travlos, R.E. Wilson, M. Eggesbø, and M.P. Longnecker. 2014. Maternal glomerular filtration rate in pregnancy and fetal size. *PLOS One* 9:e101897.
- Murli, H. 1995. *Mutagenicity Test on T-6342 in an In Vivo Mouse Micronucleus Assay*. Corning Hazleton Inc., Vienna, VA. Study No. 17073-0-455, December 14, 1995. U.S. Environmental Protection Agency Administrative Record 226-0435.
- Murli, H. 1996a. *Mutagenicity Test on T-6342 Measuring Chromosomal Aberrations in Human Whole Blood Lymphocytes with a Confirmatory Assay with Multiple Harvests*. Corning-Hazleton, Inc., Vienna, VA. Study No. 17073-0-449CO, November 1, 1996. U.S. Environmental Protection Agency Administrative Record 226-0433.
- Murli, H. 1996b. *Mutagenicity Test on T-6564 Measuring Chromosomal Aberrations in Chinese Hamster Ovary (CHO) Cells with a Confirmatory Assay with Multiple Harvests*. Corning Hazleton Inc., Vienna, VA. Study No. 17750-0-437CO, September 16, 1996. U.S. Environmental Protection Agency Administrative Record 226-0431.
- Murli, H. 1996c. *Mutagenicity Test on T-6342 Measuring Chromosomal Aberrations in Chinese Hamster Ovary (CHO) Cells with a Confirmatory Assay with Multiple Harvests*. Corning-Hazleton, Inc. Vienna, VA. Study No. 17073-0-437CO, September 16, 1996. U.S. Environmental Protection Agency Administrative Record 226-0434.
- Murli, H. 1996d. *Mutagenicity Test on T-6564 in an In Vivo Mouse Micronucleus Assay*. Corning Hazleton Inc., Vienna, VA. Study number 17750-0-455, November 1, 1996. U.S. Environmental Protection Agency Administrative Record 226-0430.

- Mylchreest, E. 2003. *PFOA: Lactational and Placental Transport Pharmacokinetic Study in Rats*. Haskell Laboratory for Health and Environmental Sciences, Newark DE, Study No. DuPont-13309, December 19, 2003.
- Nakagawa, H., T. Hirata, T. Terada, P. Jutabha, D. Miura, K.H. Harada, K. Inoue, N. Anzai, H. Endou, K. Inui, Y. Kanai, and A. Koizumi. 2007. Roles of organic anion transporters in the renal excretion of perfluorooctanoic acid. *Basic and Clinical Pharmacology & Toxicology* 103:1–8.
- Nakamura, F., Y. Ito, Y. Yanagiba, D.H. Ramdhan, Y. Kono, H. Naito, Y. Hayashi, Y. Li, T. Aoyam, F.J. Gonzalez, and T. Nakajima. 2009. Microgram-order ammonium perfluorooctanoate may activate mouse peroxisome proliferator-activated receptor α , but not human PPAR α . *Toxicology* 9:27–33.
- Newbold, R.R., E. Padilla-Banks, R.J. Snyder, T.M. Phillips, and W.N. Jefferson. 2007. Developmental exposure to endocrine disruptors and the obesity epidemic. *Reproductive Toxicology* 23:290–296.
- Nelson, J.W., E.E. Hatch, and T.F. Webster. 2010. Exposure to polyfluoroalkyl chemicals and cholesterol, body weight, and insulin resistance in the general U.S. population. *Environmental Health Perspectives* 118:197–202.
- Ngo, H.T., R.B. Hetland, A. Sabaredzovic, L.S. Haug, and I.-L. Steffensen. 2014. *In utero* exposure to perfluorooctanoate (PFOA) or perfluorooctane sulfonate (PFOS) did not increase body weight or intestinal tumorigenesis in multiple intestinal neoplasia (*Min/+*) mice. *Environmental Research* 132:251–263.
- Nolan, L.A., J.M. Nolan, F.S. Shofer, N.V. Rodway, and E.A. Emmett. 2009. The relationship between birth weight, gestational age and perfluorooctanoic acid (PFOA)-contaminated public drinking water. *Reproductive Toxicology* 27:231–238.
- Nolan, L.A., J.M. Nolan, F.S. Schofer, N.V. Rodway, and E.A. Emmett. 2010. Congenital anomalies, labor/delivery complications, maternal risk factors and their relationship with perfluorooctanoic acid (PFOA)-contaminated public drinking water. *Reproductive Toxicology* 29:147–55.
- NOTOX. 2000. *Evaluation of the Ability of T-7524 to Induce Chromosome Aberrations in Cultured Peripheral Human Lymphocytes*. NOTOX Project Number 292062. Hertogenbosch, The Netherlands.
- NRC (National Research Council). 1983. *Risk Assessment in the Federal Government: Managing the Process*. National Research Council, Committee on the Institutional Means for Assessment of Risks to Public Health, Commission on Life Sciences. National Academy Press, Washington, DC.
- O'Malley, K.D., and K.L. Ebbins. 1981. *Repeat Application 28 day Percutaneous Absorption Study with T-2618CoC in Albino Rabbits*. Riker Laboratories, St. Paul, MN. U.S. Environmental Protection Agency Administrative Record 226-0446.
- Obourn, J.D., S.R. Frame, R.H. Bell, Jr., D.S. Longnecker, G.S. Elliott, and J.C. Cook. 1997. Mechanisms for the pancreatic oncogenic effects of the peroxisome proliferator Wyeth-14,643. *Toxicology and Applied Pharmacology* 145:425–436.

- Okada, E., S. Sasaki, Y. Saijo, N. Washino, C. Miyashita, S. Kobayashi, K. Konishi, Y.M. Ito, R. Ito, A. Nakata, Y. Iwasaki, K. Saito, H. Nakazawa, and R. Kishi. 2012. Prenatal exposure to perfluorinated chemicals and relationship with allergies and infectious diseases in infants. *Environmental Research* 112:118–125.
- Okada, E., S. Sasaki, I. Kashino, H. Matsuura, C. Miyashita, S. Kobayashi, K. Itoh, T. Ikeno, A. Tamakoshi, and R. Kishi. 2014. Prenatal exposure to perfluoroalkyl acids and allergic diseases in early childhood. *Environment International* 65:127–134.
- Olsen, G.W., J.M. Burris, M.M. Burlew, and J.H. Mandel. 1998. *3M Final report: an epidemiologic investigation of plasma cholecystinin, hepatic function and serum perfluorooctanoic acid levels in production workers*. 3M Company. September 4, 1998. U.S. Environmental Protection Agency Administrative Record 226-0476.
- Olsen, G.W., J.M. Burris, M.M. Burlew, and J.H. Mandel. 2000. Plasma cholecystinin and hepatic enzymes, cholesterol and lipoproteins in ammonium perfluorooctanoate production workers. *Drug and Chemical Toxicology* 23:603–620.
- Olsen, G.W., K.J. Hansen, L.A. Clemen, J.M. Burris, and J.H. Mandel. 2001a. *Identification of Fluorochemicals in Human Tissue*. 3M Company. Final Report. June 25, 2001. U.S. Environmental Protection Agency Administrative Record 226-1030a022.
- Olsen, G.W., M.M. Burlew, J.M. Burris, and J.H. Mandel. 2001b. *A Cross-Sectional Analysis of Serum Perfluorooctane Sulfonate (PFOS) and Perfluorooctanoate (PFOA) in Relation to Clinical Chemistry, Thyroid Hormone, Hematology and Urinalysis Results from Male and Female Employee Participants of the 2000 Antwerp and Decatur Fluorochemical Medical Surveillance Program*. Final Report. 3M Company, St. Paul, MN.
- Olsen, G.W., M.M. Burlew, J.M. Burris, and J.H. Mandel. 2001c. *A Longitudinal Analysis of Serum Perfluorooctane Sulfonate (PFOS) and Perfluorooctanoate (PFOA) Levels in Relation to Lipid and Hepatic Clinical Chemistry Test Results from Male Employee Participants of the 1994/95, 1997 and 2000 Fluorochemical Medical Surveillance Program*. Final Report. 3M Company, St. Paul, MN.
- Olsen, G.W., J.M. Burris, M.M. Burlew, and J.H. Mandel. 2003. Epidemiologic assessment of worker serum perfluorooctanesulfonate (PFOS) and perfluorooctanoate (PFOA) concentrations and medical surveillance examinations. *Journal of Occupational and Environmental Medicine* 45:260–270.
- Olsen, G.W., D. Ehresman, J. Froehlich, J. Burris, and J. Butenhoff. 2005. Evaluation of the half-life ($t_{1/2}$) of elimination of perfluorooctanesulfonate (PFOS), perfluorohexanesulfonate (PFHS) and perfluorooctanoate (PFOA) from human serum. In *Fluoros*. Toronto, Canada. 18-20 August 2005. University of Toronto TOXC017. Accessed May 2016. <http://www.chem.utoronto.ca/symposium/fluoros/Flourosabstractbook.pdf>.
- Olsen, G.W., and L.R. Zobel. 2007. Assessment of lipid, hepatic, and thyroid parameters with serum perfluorooctanoate (PFOA) concentrations in fluorochemical workers. *International Archives of Occupational Environmental Health* 81:231–246.

- Olsen, G.W., J.M. Burris, D.J. Ehresman, J.W. Froehlich, A.M. Seacat, J.L. Butenhoff, and L.R. Zobel. 2007. Half-life of serum elimination of perfluorooctanesulfonate, perfluorohexanesulfonate and perfluorooctanoate in retired fluorochemical production workers. *Environmental Health Perspectives* 115:1298–1305.
- Onishchenko, N., C Fischer, W.N.W. Ibrahim, S. Negri, S. Spulbur, S. Cottica, and S. Ceccatelli. 2011. Prenatal exposure to PFOS or PFOA alters motor function in mice in a sex-related manner. *Neurotoxicity Research* 19:452–461.
- Ophaug, R.H., and L. Singer. 1980. Metabolic handling of perfluorooctanoic acid in rats. In *Proceedings of the Society of Experimental Biology and Medicine* 163:19–23.
- Ospinal-Jiménez, M., and D.C. Pozzo. 2012. Structural analysis of protein denaturation with alkyl perfluorinated sulfonates. *Langmuir* 28:17749–17760.
- Osuna, C.E., P. Grandjean, P. Weihe, and H.A. El-Fawal. 2014. Autoantibodies associated with prenatal and childhood exposure to environmental chemicals in Faroese children. *Toxicological Sciences* 142(1):158–166.
- Pastoor, T.P., K.P. Lee, M.A. Perri, and P.J. Gillies. 1987. Biochemical and morphological studies of ammonium perfluorooctanoate-induced hepatomegaly and peroxisome proliferation. *Experimental and Molecular Pathology* 47(1):98–109.
- Pennings, J.L., D.G. Jennen, U.C. Nygaard, E. Namork, L.S. Haug, H. van Loveren, and B. Granum. 2015. Cord blood gene expression supports that prenatal exposure to perfluoroalkyl substances causes depressed immune functionality in early childhood. *Journal of Immunotoxicology* 13(2):173–180.
- Pérez, F., M. Nadal, A. Navarro, F. Fàbrega, J. Domingo, J.L. Barceló, D. Barceló, and M. Farré. 2013. Accumulation of perfluoroalkyl substances in human tissues. *Environment International* 59:354–362.
- Perkins, R., J. Butenhoff, G. Kennedy, and M. Palazzolo. 2004. 13-Week dietary toxicity study of ammonium perfluorooctanoate (APFO) in male rats. *Drug & Chemical Toxicology* 27:361–378.
- Pirali, B., S. Negri, S. Chytiris, A. Perissi, L. Villani, L. La Manna, D. Cottica, M. Ferrari, M. Imbriani, M. Rotondi, and L. Chiovato. 2009. Perfluorooctane sulfate and perfluorooctanoic acid in surgical thyroid specimens of patients with thyroid diseases. *Thyroid* 19:1407–1412.
- Plummer, S.M., D.G. Farrar, and C.R. Elcombe. 2007. Comparison of gene expression changes in whole pancreas with isolated pancreatic acinar cells of rats fed diets containing Wyeth-14,643 or ammonium perfluorooctanoate. *Toxicology* 240:171–172.
- Post, G.B., P.D. Cohn, and K.R. Cooper. 2012. Perfluorooctanoic acid (PFOA), an emerging drinking water contaminant: a critical review of recent literature. *Environmental Research* 116:93–117.
- Prejean, J.D., J.C. Peckham, A.E. Casey, D.P. Griswold, E.K. Weisburger, and J.H. Weisburger. 1973. Spontaneous tumors in Sprague-Dawley rats and Swiss mice. *Cancer Research* 33:2768–2773.

- Qazi, M.R., J. Bogdanska, J.L. Butenhoff, B.D. Nelson, J.W. DePierre, and M. Abedi-Valugerdi. 2009. High dose, short-term exposure of mice to perfluorooctanesulfonate (PFOS) or perfluorooctanoate (PFOA) affects the number of circulating neutrophils differently, but enhances the inflammatory responses of macrophages to lipopolysaccharide (LPS) in a similar fashion. *Toxicology* 262:207–214.
- Qin, P., R. Liu, X. Pan, X. Fang, and Y. Mou. 2010. Impact of carbon chain length on binding of perfluoroalkyl acids to bovine serum albumin determined by spectroscopic methods. *Journal of Agriculture and Food Chemistry* 58(9):5561–5567.
- Quist, E.M., A.J. Filgo, C.A. Cummings, G.E. Kissling, and M.J. Hoenerhoff. 2015. Hepatic mitochondrial alteration in CD-1 mice associated with prenatal exposures to low doses of perfluorooctanoic acid (PFOA). *Toxicologic Pathology* 41:546–557.
- Raleigh, K.K., B.H. Alexander, G.W. Olsen, G. Ramachandran, S.Z. Morey, T.R. Church, P.W. Logan, L.L.F. Scott, and E.M. Allen. 2014. Mortality and cancer incidence in ammonium perfluorooctanoate production workers. *Occupational Environmental Medicine* 0:1–7.
- Ren, X.-M., Y.-F. Zhang, L.-H. Guo, Z.-F. Qin, Q.-Y. Lv, and L.-Y. Zhang. 2015. Structure-activity relations in binding of perfluoroalkyl compounds to human thyroid hormone T3 receptor. *Archives of Toxicology* 89:233–242.
- Rigden, M., G. Pelletier, R. Poon, J. Zhu, C. Auray-Blais, R. Gagnon, C. Kubwabo, I. Kosarck, K. Lalonde, S. Cakmak, B. Xiao, K. Leingartner, K.L. Ku, R. Bose, and J. Jiao. 2015. Assessment of urinary metabolite excretion after rat acute exposure to perfluorooctanoic acid and other peroxisomal proliferators. *Archives of Environmental Contamination and Toxicology* 68:148–158.
- Rodriguez, C.E., R.W. Setzer, and H.A. Barton. 2009. Pharmacokinetic modeling of perfluorooctanoic acid during gestation and lactation in the mouse. *Reproductive Toxicology* 27:373–386.
- Rosen, M.B., J.R. Thibodeaux, C.R. Wood, R.D. Zehr, J.E. Schmid, and C. Lau. 2007. Gene expression profiling in the lung and liver of PFOA-exposed mouse fetuses. *Toxicology* 239:15–33.
- Rosen, M.B., B.A. Abbott, D.C. Wolf, J.C. Corton, C.R. Wood, J.E. Schmid, K.P. Das, R.D. Zehr, E.T. Blair, and C. Lau. 2008a. Gene profiling in the livers of wild-type and PPAR α -null mice exposed to perfluorooctanoic acid. *Toxicologic Pathology* 36:592–607.
- Rosen, M.B., J.S. Lee, H. Ren, B. Vallanat, J. Liu, M.P. Waalkes, B.D. Abbott, C. Lau, and J.C. Corton. 2008b. Toxicogenomic dissection of the perfluorooctanoic acid transcript profile in mouse liver: evidence for the involvement of nuclear receptors PPAR α and CAR. *Toxicological Sciences* 103:46–56.
- Roth, N., and M.F. Wilks. 2014. Neurodevelopmental and neurobehavioural effects of polybrominated and perfluorinated chemicals: A systematic review of the epidemiological literature using a quality assessment scheme. *Toxicology Letters* 230(2):271–281.

- Rusch, G. 1979. *An Acute Inhalation Study of T-2305 CoC in the Rat*. Bio/dynamics, Inc., Study No. 78-7184, May 3, 1979. U.S. Environmental Protection Agency Administrative Record 226-0417.
- Sadhu, D. 2002. *CHO/HGPRT Forward Mutation Assay – ISO (T6.889.7)*. Toxicon Corporation, Bedford, MA. Report No. 01-7019-G1, March 28, 2002. U.S. Environmental Protection Agency Administrative Record 226-1101.
- Sakr, C.J., K.H. Kreckmann, J.W. Green, P.J. Gillies, J.L. Reynolds, and R.C. Leonard. 2007a. Cross-sectional study of lipids related to a serum biomarker of exposure (ammonium perfluorooctanoate or APFO) as part of a general health survey in a cohort of occupationally exposed workers. *Journal of Occupational and Environmental Medicine* 49:1086–1096.
- Sakr, C.J., R.C. Leonard, K.H. Kreckmann, M.D. Slade, and M.R. Cullen. 2007b. Longitudinal study of serum lipids and liver enzymes in workers with occupational exposure to ammonium perfluorooctanoate. *Journal of Occupational and Environmental Medicine* 49:872–879.
- Sakr, C.J., J.M. Symons, K.H. Kreckmann, and R.C. Leonard. 2009. Ischemic heart disease mortality study among workers with occupational exposure to ammonium perfluorooctanoate. *Occupational and Environmental Medicine* 66:699–703.
- Saladin, K.S. 2004. The Lymphatic and Immune System. Chapter 21 in *Anatomy & Physiology: The Unity of Form and Function*. 3rd ed, McGraw Hill, Boston, MA.
- Salvalaglio, M., I. Muscionico, and C. Cavallotti. 2010. Determination of energies and sites of binding of PFOA and PFOS to human serum albumin. *Journal of Physical Chemistry B* 114(46):14860–14874.
- Savitz, D.A. 2007. Biomarkers of perfluorinated chemicals and birth weight. *Environmental Health Perspectives* 115:A528–A529.
- Savitz, D.A., C.R. Stein, S.M. Bartell, B. Elston, J. Gong, H.M. Shin, and G.A. Wellenius. 2012a. Perfluorooctanoic acid exposure and pregnancy outcome in a highly exposed community. *Epidemiology* 23:386–92.
- Savitz, D.A., C.R. Stein, B. Elston, G.A. Wellenius, S.M. Bartell, H.M. Shin, V.M. Vieira, and T. Fletcher. 2012b. Relationship of perfluorooctanoic acid exposure to pregnancy outcome based on birth records in the mid-Ohio Valley. *Environmental Health Perspectives* 120:1201–1207.
- Seals, R., S.M. Bartell, and K. Steenland. 2011. Accumulation and clearance of perfluorooctanoic acid (PFOA) in current and former residents of an exposed community. *Environmental Health Perspectives* 119:119–124.
- Shabalina, I.G., A.V. Kalinovich, B. Cannon, and J. Nedergaard. 2015 (epub). Metabolically inert perfluorinated fatty acids directly activate uncoupling protein 1 in brown-fat mitochondria. *Archives of Toxicology* 90(5):1117–1128.
- Shankar, A., J. Xiao, and A. Ducatman. 2011. Perfluoroalkyl chemicals and chronic kidney disease in US adults. *American Journal of Epidemiology* 174(8):893–900.

- Sheng, N., J. Li, H. Liu, A. Zhang, and J. Dai. 2016. Interaction of perfluoroalkyl acids with human liver fatty acid binding protein. *Archives of Toxicology* 90(1):217–227.
- Shin H.-M., V.M. Vieira P.B. Ryan, R. Detwiler, B. Sanders, K. Steenland, and S.M. Bartell. 2011. Environmental fate and transport modeling for perfluorooctanoic acid emitted from the Washington Works Facility in West Virginia. *Environmental Science & Technology* 45:1435–1442.
- Shrestha, S., M.S. Bloom, R. Yucel, R.F. Seegal, Q. Wu, K. Kannan, R. Rej, and E.F. Fitzgerald. 2015. Perfluoroalkyl substances and thyroid function in older adults. *Environment International* 75:206–214.
- SIAR (SIDS Initial Assessment Report). 2006. *Draft SIDS Initial Assessment Report. Screening Information Data Sets*. Meeting 22, Organization for Economic Cooperation and Development. Paris, France. April 18-21. Accessed May 2016. http://webnet.oecd.org/HPV/UI/SIDS_Details.aspx?id=15d35628-21d2-45f6-8556-e2832414f1c1.
- Simpson, C., A. Winquist, C. Lally, and K. Steenland. 2013. Relation between perfluorooctanoic acid exposure and strokes in a large cohort living near a chemical plant. *Environmental Research* 127:22–28.
- Slitt, A.L., K. Allen, J. Morrone, L.M. Aleksunes, C. Chen, J.M. Maher, J.E. Manautou, N.J. Cherrington, and C.D. Klaassen. 2007. Regulation of transporter expression in mouse liver, kidney, and intestine during extrahepatic cholestasis. *Biochimica et Biophysica Acta (BBA)-Biomembranes* 1768(3):637–647.
- Slotkin, T.A., E.A. MacKillop, R.L. Melnick, K.A. Thayer, and F.J. Seidler. 2008. Developmental neurotoxicity of perfluorinated chemicals models *in vitro*. *Environmental Health Perspectives* 116:716–722.
- Son, H.-Y., A.-H. Kim, H.-I. Shin, H.-I. Bae, and J.-H. Yang. 2008. Perfluorooctanoic acid-induced hepatic toxicity following 21-day oral exposure in mice. *Archives of Toxicology* 82:239–246.
- Son, H.-Y., S. Lee, E.-N. Tak, H.-S. Cho, H.-I. Shin, S.-H. Kim, and J.-H. Yang. 2009. Perfluorooctanoic acid alters T lymphocyte phenotypes and cytokine expression in mice. *Environmental Toxicology* 24:580–588.
- Spector, A.A. 2000. Lipid Metabolism: Essential Fatty Acids in: *Biochemical and Physiological Aspects of Human Nutrition*. Stipanuk, M.H., ed. Saunders Company, Philadelphia, PA. p. 365–383.
- SPI (Society of the Plastics Industry). 2005. *The Society of the Plastics Industry: Dispersion Processor Material Balance Project*. OPPT-2003-0012-0900 through -0904. 2005/02.
- SRC (Syracuse Research Corporation). 2016. *PHYSROP Database*. Accessed May 2016. <http://www.srcinc.com/what-we-do/environmental/scientific-databases.html>.
- Staples, R.E., B.A. Burgess, and W.D. Kerns. 1984. The embryo-fetal toxicity and teratogenic potential of ammonium perfluorooctanoate (APFO) in the rat. *Fundamental & Applied Toxicology* 4:429–440.

- Starkov, A.A., and K.B. Wallace. 2002. Structural determinants of fluorochemical-induced mitochondrial dysfunction. *Toxicological Sciences* 66(2):244–252.
- Starling, A.P., S.M. Engel, K.W. Whitworth, D.B. Richardson, A.M. Stuebe, J.L. Daniels, L.S. Haug, M. Eggesbø, G. Becher, A. Sabaredzovic, C. Thomsen, R.E. Wilson, G.S. Travlos, J.A. Hoppin, D.D. Baird, and M.P. Longnecker. 2014. Perfluoroalkyl substances and lipid concentrations in plasma during pregnancy among women in the Norwegian Mother and Child Cohort Study. *Environment International* 62:104–112.
- Steenland, K., S. Tinker, S. Frisbee, A. Ducatman, and V. Vaccarino. 2009. Association of perfluorooctanoic acid and perfluorooctane sulfonate with serum lipids among adults living near a chemical plant. *American Journal of Epidemiology* 170:1269–1278.
- Steenland, K., S. Tinker, A. Shankar, and A. Ducatman. 2010. Association of perfluorooctanoic acid (PFOA) and perfluorooctanesulfonate (PFOS) with uric acid among adults with elevated community exposure to PFOA. *Environmental Health Perspectives* 118:229–233.
- Steenland, K., and S. Woskie. 2012. Cohort mortality study of workers exposed to perfluorooctanoic acid. *American Journal of Epidemiology* 176:909–917.
- Steenland, K., L. Zhao, and A. Winquist. 2015. A cohort incidence study of workers exposed to perfluorooctanoic acid (PFOA). *Occupational & Environmental Medicine* 0:1–8.
- Stein, C.R., D.A. Savitz, and M. Dougan. 2009. Serum levels of perfluorooctanoic acid and perfluorooctane sulfonate and pregnancy outcome. *American Journal of Epidemiology* 170:837–846.
- Stein, C.R., D.A. Savitz, and D.C. Bellinger. 2013. Perfluorooctanoate exposure in a highly exposed community and parent and teacher reports of behaviour in 6-12-year-old children. *Paediatric & Perinatal Epidemiology* 28:146–156.
- Stein, C.R., D.A. Savitz, B. Elston, P.G. Thorpe, and S.M. Gilboa. 2014. Perfluorooctanoate exposure and major birth defects. *Reproductive Toxicology* 47:15–20.
- Suh, C.H., N.K. Cho, C.K. Lee, C.H. Lee, D.W. Kim, J.H. Kim, B.C. Son, and J.T. Lee. 2011. Perfluorooctanoic acid-induced inhibition of placental-family hormone and fetal growth retardation in mice. *Molecular & Cellular Endocrinology* 337(1–2):7–15.
- Sykes, G. 1987. *Two-year Toxicology/carcinogenicity Study of Fluorochemical FC-143 in Rats*. Memo from G Sykes to C Reinhardt, Haskell Laboratory for Toxicology and Industrial Medicine, October 29, 1987.
- Takacs, M.L., and B.D. Abbott. 2007. Activation of mouse and human peroxisome proliferator-activated receptors ($\alpha, \beta/\delta, \gamma$) by perfluorooctanoic acid and perfluorooctane sulfonate. *Toxicological Sciences* 95:108–117.
- Takagi A., K. Sai, T. Umemur, R. Hasegawa, and Y. Kurokawa. 1991. Short-term exposure to the peroxisome proliferators, perfluorooctanoic acid and perfluorodecanoic acid, causes significant increase of 8-hydroxydeoxyguanosine in liver DNA of rats. *Cancer Letters* 57:55–60.

- Tan, Y.-M., H.J. Clewell III, and M.E. Andersen. 2008. Time dependencies in perfluorooctylacids disposition in rat and monkeys: a kinetic analysis. *Toxicology Letters* 177:38–47.
- Tan, F., Y. Jin, W. Liu, X. Quan, J. Chen, and Z. Liang. 2012. Global liver proteome analysis using iTRAQ labeling quantitative proteomic technology to reveal biomarkers in mice exposed to perfluorooctane sulfonate (PFOS). *Environmental Science & Technology* 46:12170–12177.
- Tan, X., G. Xie, X. Sun, Q. Li, W. Zhong, P. Oiao, X. Sun, W. Jai, and Z. Zhou. 2013. High fat diet feeding exaggerates perfluorooctanoic acid-induced liver injury in mice via modulating multiple metabolic pathways. *PLOS One* 8(4):e61409.
- Tao, L., K. Kannan, C.M. Wong, K.F. Arcaro, and J.L. Butenhoff. 2008. Perfluorinated compounds in human milk from Massachusetts, U.S.A. *Environmental Science & Technology* 42:3096–3101.
- Taylor, K.W., R.F. Novak, H.A. Anderson, L.S. Birnbaum, C. Blystone, M. DeVito, D. Jacobs, J. Köhrle, L. Duk-Hee, L. Rylander, and A. Rignell-Hydbom. 2013. Evaluation of the association between persistent organic pollutants (POPs) and diabetes in epidemiological studies: a national toxicology program workshop review. *Environmental Health Perspectives* 121(7):774–783.
- Taylor, K.W., K. Hoffman, K.A. Thayer, and J.L. Daniels. 2014. Polyfluoroalkyl chemicals and menopause among women 20-65 years of age (NHANES). *Environmental Health Perspectives* 122:145–150.
- Teerds, K.J., F.F.G. Rommerts, and J.H. Dorrington. 1990. Immunohistochemical detection of transforming growth factor- α in Leydig cells during the development of the rat testis. *Molecular & Cellular Endocrinology* 69:R1–R6.
- Thomford, P.J. 2001. *4-Week capsule toxicity study with ammonium perfluorooctanoate (APFO) in cynomolgus monkeys*. Study performed by Covance Laboratories Inc., Madison, WI 53704-2592 for APME Ad-hoc APFO Toxicology Working Group. Study No. Covance 6329-230, Completion Date December 18, 2001, 159 pp. U.S. Environmental Protection Agency Administrative Record 226-1052a.
- Thompson, J., M. Lorber, L.-M.L. Toms, K. Kato, A.M. Calafat, and J.F. Mueller. 2010. Use of simple pharmacokinetic modeling to characterize exposure of Australians to perfluorooctanoic acid and perfluorooctane sulfonic acid. *Environment International* 36:390–397.
- Thomsen, C., L.S. Haug, H. Stgum, M. Frøshaug, S.L. Broadwell, and G. Becher. 2010. Changes in concentrations of perfluorinated compounds, polybrominated diphenyl ethers, and polychlorinated biphenyls in Norwegian breast-milk during twelve months of lactation. *Environmental Science & Technology* 44(24):9550–9556.
- Thottassery, J., L. Winberg, J. Yousseff, M. Cunningham, and M. Badr. 1992. Regulation of perfluorooctanoic acid-induced peroxisomal enzyme activities and hepatocellular growth by adrenal hormones. *Hepatology* 15:316–322.

- Trosko, J.E., C.C. Chang, B.L. Upham, and M. Wilson. 1998. Epigenetic toxicology as toxicant-induced changes in intracellular signaling leading to altered gap junctional intercellular communication. *Toxicology Letters* 102–103:71–78.
- Tucker, D.E., M.B. Macon, M.J. Strynar, S. Dragnino, E. Andersen, and S.E. Fenton. 2015. The mammary gland is a sensitive pubertal target in CD-1 and C57BL/6 mice following perinatal perfluorooctanoic acid (PFOA) exposure. *Reproductive Toxicology* 54:26–36.
- UNEP (United Nations Environmental Program). 2015. *Proposal to List Pentadecafluorooctanoic Acid (CAS No: 335-67-1, PFOA, Perfluorooctanoic Acid), its Salts and PFOA-related Compounds in Annexes A, B and/or C to the Stockholm Convention on Persistent Organic Pollutants*. UNEP/POPS/POPRC.11/5. Persistent Organic Pollutants Review Committee, Eleventh meeting Rome, Italy, October 19-23, 2015. Accessed May 2016. [http://www.bennington.edu/docs/default-source/docs-pfoa/un-stockholm-convention-review-of-pfoa-\(2016\).pdf?sfvrsn=2](http://www.bennington.edu/docs/default-source/docs-pfoa/un-stockholm-convention-review-of-pfoa-(2016).pdf?sfvrsn=2).
- Upham, B.L., N.D. Deocampo, B. Wurl, and J.E. Trosko. 1998. Inhibition of gap junctional intercellular communication by perfluorinated fatty acids is dependent on the chain length of the fluorinated tail. *International Journal of Cancer* 78:491–495.
- Upham, B.L., J-S. Park, P. Babica, I. Sovadinova, A.R. Rummel, J.E. Trosko, A. Hirose, R. Hasegawa, J. Kanno, and K. Sai. 2009. Structure-activity-dependent regulation of cell communications by perfluorinated fatty acids using *in vivo* and *in vitro* model systems. *Environmental Health Perspectives* 117:545–551.
- USEPA (U.S. Environmental Protection Agency). 1986a. Guidelines for the Health Risk Assessment of Chemical Mixtures. *Federal Register* 51(185):34014–34025.
- USEPA (U.S. Environmental Protection Agency). 1986b. Guidelines for Mutagenicity Risk Assessment. *Federal Register* 51(185):34006–34012.
- USEPA (U.S. Environmental Protection Agency). 1988. *Recommendations for and Documentation of Biological Values for Use in Risk Assessment*. EPA 600/6-87/008. National Technical Information Service, Springfield, VA; PB88-179874/AS.
- USEPA (U.S. Environmental Protection Agency). 1991. Guidelines for Developmental Toxicity Risk Assessment. *Federal Register* 56(234):63798–63826.
- USEPA (U.S. Environmental Protection Agency). 1994a. Interim Policy for Particle Size and Limit Concentration Issues in Inhalation Toxicity Studies. *Federal Register* 59(206):53799.
- USEPA (U.S. Environmental Protection Agency). 1994b. *Methods for Derivation of Inhalation Reference Concentrations and Application of Inhalation Dosimetry*. EPA/600/8-90/066F. National Technical Information Service, Springfield, VA; PB2000-500023. Accessed May 2016. <https://cfpub.epa.gov/ncea/risk/recordisplay.cfm?deid=71993&CFID=57984601&CFTOKEN=76387071>.

- USEPA (U.S. Environmental Protection Agency). 1995. *Use of the Benchmark Dose Approach in Health Risk Assessment*. EPA/630/R-94/007. National Technical Information Service, Springfield, VA; PB95-213765. Accessed May 2016.
http://hero.epa.gov/index.cfm/reference/download/reference_id/5992.
- USEPA (U.S. Environmental Protection Agency). 1996. Guidelines for Reproductive Toxicity Risk Assessment. *Federal Register* 61(212):56274–56322. Accessed May 2016.
<https://www.gpo.gov/fdsys/pkg/FR-1996-10-31/pdf/96-27473.pdf>.
- USEPA (U.S. Environmental Protection Agency). 1998. Guidelines for Neurotoxicity Risk Assessment. *Federal Register* 63(93):26926–26954. Accessed May 2016.
https://www.epa.gov/sites/production/files/2014-11/documents/neuro_tox.pdf.
- USEPA (U.S. Environmental Protection Agency). 2000a. *Science Policy Council Handbook: Peer Review*. 2nd ed. EPA 100-B-00-001. Office of Science Policy, Office of Research and Development, Washington, DC. Accessed May 2016.
<http://nepis.epa.gov/EPA/html/DLwait.htm?url=/Exe/ZyPDF.cgi/50000UAG.PDF?Dockey=50000UAG.PDF>.
- USEPA (U.S. Environmental Protection Agency). 2000b. *Supplemental Guidance for Conducting for Health Risk Assessment of Chemical Mixtures*. EPA/630/R-00/002. Accessed May 2016. <https://cfpub.epa.gov/ncea/risk/recordisplay.cfm?deid=20533>.
- USEPA (U.S. Environmental Protection Agency). 2002a. *A Review of the Reference Dose and Reference Concentration Processes*. EPA/630/P-02/0002F. Risk Assessment Forum, Washington, DC. Accessed May 2016.
<https://www.epa.gov/osa/review-reference-dose-and-reference-concentration-processes>.
- USEPA (U.S. Environmental Protection Agency). 2002b. *Memorandum from Dr. Ralph Cooper, NHEERL, to Dr. Jennifer Seed*, dated October 2, 2002.
- USEPA (U.S. Environmental Protection Agency). 2002c. *Memorandum from Dr. Elizabeth Margosches to Dr. Katherine Anitole*, dated October 21, 2002.
- USEPA (U.S. Environmental Protection Agency). 2005a. *Guidelines for Carcinogen Risk Assessment*. EPA/630/P-03/001B. Risk Assessment Forum, Washington, DC. Accessed May 2016. <https://www.epa.gov/risk/guidelines-carcinogen-risk-assessment>.
- USEPA (U.S. Environmental Protection Agency). 2005b. *Supplemental Guidance for Assessing Susceptibility from Early-life Exposure to Carcinogens*. EPA/630/R-03/003F. Risk Assessment Forum, Washington, DC. Accessed May 2016.
<https://www.epa.gov/risk/supplemental-guidance-assessing-susceptibility-early-life-exposure-carcinogens>.

- USEPA (U.S. Environmental Protection Agency). 2005c. *Draft Risk Assessment of the Potential Human Health Effects Associated with Exposure to Perfluorooctanoic Acid and its Salts*. SAB Review Draft. Accessed May 2016.
<http://nepis.epa.gov/Exe/ZyNET.exe/9101AQFL.TXT?ZyActionD=ZyDocument&Client=EPA&Index=2000+Thru+2005&Docs=&Query=&Time=&EndTime=&SearchMethod=1&TocRestrict=n&Toc=&TocEntry=&QField=&QFieldYear=&QFieldMonth=&QFieldDay=&IntQFieldOp=0&ExtQFieldOp=0&XmlQuery=&File=D%3A%5Czyfiles%5CIndex%20Data%5C00thru05%5CTxt%5C00000031%5C9101AQFL.txt&User=ANONYMOUS&Password=anonymous&SortMethod=h%7C-&MaximumDocuments=1&FuzzyDegree=0&ImageQuality=r75g8/r75g8/x150y150g16/i425&Display=p%7Cf&DefSeekPage=x&SearchBack=ZyActionL&Back=ZyActionS&BackDesc=Results%20page&MaximumPages=1&ZyEntry=1&SeekPage=x&ZyPURL>.
- USEPA (U.S. Environmental Protection Agency). 2006a. *Science Policy Council Handbook: Peer Review*. 3rd ed. EPA/100/B-06/002. Prepared for the U.S. Environmental Protection Agency by Members of the Peer Review Advisory Group, for EPA's Science Policy Council. Washington, DC. Accessed May 2016.
https://www.epa.gov/sites/production/files/2015-09/documents/peer_review_handbook_2006_3rd_edition.pdf.
- USEPA. (U.S. Environmental Protection Agency). 2006b. *A Framework for Assessing Health Risk of Environmental Exposures to Children (Final)*. EPA/600/R-05/093F. Washington, DC. Accessed May 2016. <https://cfpub.epa.gov/ncea/risk/recordisplay.cfm?deid=158363>.
- USEPA (U.S. Environmental Protection Agency). 2011. *Exposure Factors Handbook: 2011 Edition (Final)*. EPA/600/R-090/052F. Office of Research and Development, National Center for Environmental Assessment, Washington, D.C. 1436 pp. Accessed May 2016.
<https://cfpub.epa.gov/ncea/risk/recordisplay.cfm?deid=236252>.
- USEPA (U.S. Environmental Protection Agency). 2012. *Benchmark Dose Technical Guidance*. EPA/100/R-12/001. Risk Assessment Forum, Washington, DC.
- USEPA (U.S. Environmental Protection Agency). 2014a. *Framework for Human Health Risk Assessment to Inform Decision Making*. EPA/100/R-14/001. Risk Assessment Forum, Washington, DC. Accessed May 2016. <https://www.epa.gov/risk/framework-human-health-risk-assessment-inform-decision-making>.
- USEPA. (U.S. Environmental Protection Agency). 2014b. *Child-Specific Exposure Scenarios Examples (Final Report)*. EPA/600/R-14-217F. Washington, DC.
- USEPA (U.S. Environmental Protection Agency). 2014c. *Emerging Contaminants Fact Sheet – Perfluorooctane Sulfonate (PFOS) and Perfluorooctanoic Acid (PFOA)*. EPA 505-F-14-001. U.S. Environmental Protection Agency, Solid Waste and Emergency Response. Accessed May 2016. <http://nepis.epa.gov/Exe/ZyPDF.cgi/P100LTG6.PDF?Dockey=P100LTG6.PDF>.
- USEPA (U.S. Environmental Protection Agency). 2015. *ToxCast & Tox21 Summary Files from invitrodb_v2*. Accessed May 2016.
<http://www2.epa.gov/chemical-research/toxicity-forecaster-toxcasttm-data>.

- Vanden Heuvel, J.P. 2013. Comment on “Associations between PFOA, PFOS and changes in the expression of genes involved in cholesterol metabolism in humans”. *Environment International* 1(61):150–153.
- Vassiliadou, I., D. Costopoulou, A. Ferderigou, and L. Leondiadis. 2010. Levels of perfluorooctanesulfonate (PFOS) and perfluorooctanoate (PFOA) in blood samples from different groups of adults living in Greece. *Chemosphere* 80:1199–1206.
- Vélez, M.P., T.E. Arbuckle, and W.D. Fraser. 2015. Maternal exposure to perfluorinated chemicals and reduced fecundity: the MIREC study. *Human Reproduction* 30:701–709.
- Verner, M.A., and M.P. Longnecker. 2015. Comment on “Enhanced elimination of perfluorooctanesulfonic acid by menstruating women: Evidence from population-based pharmacokinetic modeling”. *Environmental Science & Technology* 49(9):5836–5837.
- Verner, M.-A., A.E. Luccisano, N.-H. Morken, M. Yoon, H. Wu, R. McDougall, M. Maisonet, M. Marcus, R. Kishi, C. Miyashita, M.-H. Chen, W.-S. Hsieh, M.E. Andersen, H.J. Clewell, and M.P. Longnecker. 2015. Associations of perfluoroalkyl substances (PFASs) with lower birth weight: an evaluation of potential confounding by glomerular filtration rate using a physiologically based pharmacokinetic model (PBPK). *Environmental Health Perspectives* 123:1317–1324.
- Vested, A., C.H. Ramlau-Hansen, S.F. Olsen, J.P. Bonde, S.L. Kristensen, T.I. Halldorsson, G. Becher, L.S. Haug, E.H. Ernst, and G. Toft. 2013. Associations of *in utero* exposure to perfluorinated alkyl acids with human semen quality and reproductive hormones in adult men. *Environmental Health Perspectives* 121(4):453–458.
- Vesterinen, H.M., P.I. Johnson, D.S. Atchley, P. Sutton, J. Lam, M.G. Zlatnik, S. Sen, and T.J. Woodruff. 2014. Fetal growth and maternal glomerular filtration rate: a systematic review. *Journal of Maternal-Fetal & Neonatal Medicine* 28:2176–2181.
- Vieira, V.M., K. Hoffman, H.-M. Shin, J.M. Weinberg, T.F. Webster, and T. Fletcher. 2013. Perfluorooctanoic acid exposure and cancer outcomes in a contaminated community: a geographic analysis. *Environmental Health Perspectives* 121(3): 318–323.
- Völkel, W., O. Genzel-Boroviczény, H. Demmelmair, C. Gebauer, B. Koletzko, D. Twardella, R. Raab, and H. Fromme. 2008. Perfluorooctane sulphonate (PFOS) and perfluorooctanoic acid (PFOA) in human breast milk: results of a pilot study. *International Journal of Hygiene & Environmental Health* 211:440–446.
- Von Ehrenstein, O.S., S.E. Fenton, K. Kato, Z. Kuklennyik, A.M. Calafat, and E.P. Hines. 2009. Polyfluoroalkyl chemicals in the serum and milk of breastfeeding women. *Reproductive Toxicology* 27:239–245.
- Wallace, K.B., G.E. Kissling, R.L. Melnick, and C.R. Blystone. 2013. Structure-activity relationships for perfluoroalkane-induced *in vitro* interference with rat liver mitochondrial respiration. *Toxicology Letters* 222:257–264.

- Wallington, T.J., M.D. Hurley, J. Xia, D.J. Wuebbles, S. Sillman, A. Ito, J.E. Penner, D.A. Ellis, J. Martin, S.A. Mabury, O.J. Nielsen, and M.P. Sulbaek Andersen. 2006. Formation of C7F15COOH (PFOA) and other perfluorocarboxylic acids during the atmospheric oxidation of 8:2 fluorotelomer alcohol. *Environmental Sciences & Technology* 40:924–930.
- Walrath, J., and C. Burke. 1989. *An Investigation into the Occurrence of Leukemia at Washington Works. E.I. Dupont De Nemours and Company*, April 1989. U.S. Environmental Protection Agency Administrative Record 226-1308-1.
- Walters, M.W., J.A. Bjork, and K.B. Wallace. 2009. Perfluorooctanoic acid stimulated mitochondrial biogenesis and gene transcription in rats. *Toxicology* 264:10–15.
- Wambaugh, J., H.A. Barton, and R.W. Setzer. 2008. Comparing models for perfluorooctanoic acid pharmacokinetics using Bayesian analysis. *Journal of Pharmacokinetics & Pharmacodynamics* 35:683–712.
- Wambaugh, J.F., R.W. Setzer, A.M. Pitruzzello, J. Liu, D.M. Reif, N.C. Kleinstreuer, N. Ching, Y. Wang, N. Sipes, M. Martin, K. Das, J.C. DeWitt, M. Strynar, R. Judson, K.A. Houck, and C. Lau. 2013. Dosimetric anchoring of *in vivo* and *in vitro* studies for perfluorooctanoate and perfluorooctanesulfonate. *Toxicological Sciences* 136:308–327.
- Wan, H.T., Y.G. Zhao, X. Wei, K.Y. Hui, J.P. Giesy, and C.K.C. Wong. 2012. PFOS-induced hepatic steatosis, the mechanistic actions on β -oxidation and lipid transport. *Biochimica et Biophysica Acta* 1820:1092–1101.
- Wan, H.T., D.D. Mruk, K.C. Wong, and C.Y. Cheng. 2014a. Perfluorooctanesulfonate (PFOS) perturbs male rat sertoli cell blood-testes barrier function affecting F-actin organization via p-FAK-Tyr⁴⁰⁷: An *in vitro* study. *Endocrinology* 155(1):249–262.
- Wan, H.T., Y.G. Zhao, P.Y. Leung, and C.K.C. Wong. 2014b. Perinatal exposure to perfluorooctane sulfonate affects glucose metabolism in adult offspring. *PLOS ONE* 9:e87137.
- Wang, Y., A.P. Starling, L.S. Haug, M. Eggesbo, G. Becher, C. Thomsen, G. Travlos, D. King, J.A. Hoppin, W.J. Rogan, and M.P. Longnecker. 2013. Association between perfluoroalkyl substances and thyroid stimulating hormone among pregnant women: a cross-sectional study. *Environmental Health* 12:76.
- Wang, L., Y. Wang, Y. Liang, J. Li, Y. Liu, J. Zhang, A. Zhang, J. Fu, and G. Jiang. 2014. PFOS induced lipid metabolism disturbances in BALB/c mice through inhibition of low density lipoproteins excretion. *Scientific Reports* 4:4582.
- Wang, S., Q. Lv, Y. Yang, L.-H. Guo, B. Wan, and L. Zhao. 2014. Cellular target recognition of perfluoroalkyl acids: *in vitro* evaluation of inhibitory effects on lysine decarboxylase. *Science of the Total Environment* 496:381–388.
- Wang, F., W. Liu, Y. Jin, F. Wang, and J. Ma. 2015. Prenatal and neonatal exposure to perfluorooctane sulfonic acid results in aberrant changes in miRNA expression profile and levels in developing rat livers. *Environmental Toxicology* 30(6):712–723.

- Wang, Y., W. Liu, Q. Zhang, H. Zhao, and X. Quan. 2015. Effects of developmental perfluorooctane sulfonate exposure on spatial learning and memory ability of rats and mechanism associated with synaptic plasticity. *Food and Chemical Toxicology* 76:70–76.
- Washino, N., Y. Saijo, S. Sasaki, S. Kato, S. Ban, K. Konishi, R. Ito, A. Nakata, Y. Iwasaki, K. Saito, H. Nakazawa, and R. Kishi. 2009. Correlations between prenatal exposure to perfluorinated chemicals and reduced fetal growth. *Environmental Health Perspectives* 117:660–667.
- Watkins, D.J., J. Josson, B. Elston, S.M. Bartell, H.-M. Shin, V.M. Vieira, D.A. Savitz, T. Fletcher, and G.A. Wellenius. 2013. Exposure to perfluoroalkyl acids and markers of kidney function among children and adolescents living near a chemical plant. *Environmental Health Perspectives* 121:625–630.
- Weaver, Y.M., D.J. Ehresman, J.L. Butanhoff, and B. Hagenbuch. 2010. Roles of renal organic anion transporters in transporting perfluorinated carboxylates with different chain lengths. *Toxicological Sciences* 113:305–314.
- Webster, G.M., S.A. Venners, A. Mattman, and J.W. Martin. 2014. Associations between perfluoroalkyl acids (PFASs) and maternal thyroid hormones in early pregnancy: a population-based cohort study. *Environmental Research* 133:338–347.
- Webster, G.M., S.A. Rauch, N. Ste Marie, A. Mattman, B.P. Lanphear, and S.A. Venners. 2015. Cross-sectional associations of serum perfluoroalkyl acids and thyroid hormones in U.S. adults: Variation according to TPOAb and Iodine status (NHANES 2007–2008). *Environmental Health Perspectives*.
- Weiss, J.M., P.L. Andersson, M.H. Lamoree, P.E.G. Leonards, S.P.J. van Leeuwen, and T. Hamers. 2009. Competitive binding of poly- and perfluorinated compounds to the thyroid hormone transport protein transthyretin. *Toxicological Sciences* 109:206–216.
- Weldon, R., W. Neal, J. Collin, G. Lorna, B. Eskanzi, and R. Fletcher. 2013. In utero PFOA and high blood pressure among pre-adolescent children in West Virginia. *Environmental and Health-Basel*, abstract number: 5534-O-142-04.
- Wen, L.-L., L.-Y. Lin, T.-Chen. Su, P.-C. Chen, and C.-Y. Lin. 2013. Association between serum perfluorinated chemicals and thyroid function in U.S. adults: The national health and nutrition examination survey 2007-2010. *Journal of Clinical Endocrinology & Metabolism* 98(9):E1456–E1464.
- White, S.S., A.M. Calafat, A. Kuklennyik, L. Villanueva, R.D. Zehr, L. Helfant, M.J. Strynar, A.B. Lindstrom, J.R. Thibodeaux, C. Wood, and S.E. Fenton. 2007. Gestational PFOA exposure of mice is associated with altered mammary gland development in dams and female offspring. *Toxicological Sciences* 96:133–144.
- White, S.S., K. Kato, L.T. Jia, B.J. Basden, A.M. Calafat, E.P. Hines, J.P. Stanko, C.J. Wolf, B.D. Abbott, and S.E. Fenton. 2009. Effects of perfluorooctanoic acid on mouse mammary gland development and differentiation resulting from cross-foster and restricted gestational exposures. *Reproductive Toxicology* 27:289–298.

- White, S.S., J.P. Stanko, K. Kato, A.M. Calafat, E.P. Hines, and S.E. Fenton. 2011. Gestational and chronic low-dose PFOA exposures and mammary gland growth and differentiation in three generations of CD-1 mice. *Environmental Health Perspectives* 119(8):1070–1076.
- Whitney, E.N., Cataldo, C.B. and S.R. Rolfes. 1987. *Understanding Normal and Clinical Nutrition*. West Publishing Company, St. Paul, MN. p. 500.
- Whitworth, K.W., L.S. Haug, D.D. Baird, G. Becher, J.A. Hoppin, R. Skjaerven, C. Thomsen, M. Eggesbo, G. Travlos, R. Wilson, and M.P. Longnecker. 2012. Perfluorinated compounds and subfecundity in pregnant women. *Epidemiology* 23:257–263.
- WHO (World Health Organization). 2012. *Guidance for Immunotoxicity Risk Assessment for Chemicals*. IPCS Harmonization Project Document No. 10.
- Wilcox, A.J. 2010. *Fertility and Pregnancy: an Epidemiologic Perspective*. Oxford University Press New York, NY. p. 192–229.
- Winqvist, A., C. Lally, H.M. Shin, and K. Steenland. 2013. Design, methods, and population for a study of PFOA health effects among highly exposed mid-Ohio valley community residents and workers. *Environmental Health Perspectives* 121(8):896–899.
- Winqvist, A., and K. Steenland. 2014a. Modeled PFOA exposure and coronary artery disease, hypertension, and high cholesterol in community and worker cohorts. *Environmental Health Perspectives* 122:1299–1305.
- Winqvist, A., and K. Steenland. 2014b. Perfluorooctanoic acid exposure and thyroid disease in community and worker cohorts. *Epidemiology* 25:255–264.
- Wisnoski, N.C., C.M. Townsend, Jr., W.H. Nealon, J.L. Freeman, and T.S. Riall. 2008. 672 Patients with acinar cell carcinoma of the pancreas: a population-based comparison to pancreatic adenocarcinoma. *Surgery* 144: 141–148.
- Wolf, C.J., S.E. Fenton, J.E. Schmid, A.M. Calafat, Z. Kuklennyik, X.A. Bryant, J. Thibodeaux, K.P. Das, S.S. White, C.S. Lau, and B.D. Abbott. 2007. Developmental toxicity of perfluorooctanoic acid in the CD-1 mouse after cross-foster and restricted gestational exposure. *Toxicological Sciences* 95:462–473.
- Wolf, D.C., T. Moore, B.D. Abbott, M.B. Rosen, K.P. Das, R.D. Zehr, A.B. Lindstrom, M.J. Strynar, and C. Lau. 2008a. Comparative hepatic effects of perfluorooctanoic acid and WY 14,643 in PPAR α knockout and wild-type mice. *Toxicologic Pathology* 36:632–639.
- Wolf, C.J., M.L. Takacs, J.E. Schmid, C. Lau, and B.D. Abbott. 2008b. Activation of mouse and human peroxisome proliferator- activated receptor alpha by perfluoroalkyl acids of different functional groups and chain lengths. *Toxicological Sciences* 106:162–171.
- Wolf, C., J. Schmid, C. Lau, and B. Abbott. 2012. Activation of mouse and human peroxisome proliferator- activated receptor-alpha (PPAR α) by perfluoroalkyl acids (PFAAs); further investigation of C4-C12 compounds. *Reproductive Toxicology* 33:546–551.
- Woodruff, T.J., and P. Sutton. 2014. The navigation guide systematic review methodology: A rigorous and transparent method for translating environmental health science into better health outcomes. *Environmental Health Perspectives* 122:1007–1014.

- Wong, F., M. MacLeod, J.F. Mueller, and I.T. Cousins. 2014. Enhanced elimination of perfluorooctane sulfonic acid by menstruating women: evidence from population-based pharmacokinetic modeling. *Environmental Science & Technology* 48:8807–8814.
- Wu, L., H. Gao, N. Gao, F. Chen, and L. Chen. 2009. Interaction of perfluorooctanoic acid with human serum albumin. *BMC Structural Biology* 9:31.
- Yager, J.D., Jr., and R. Yager. 1980. Oral contraceptive steroids as promoters of hepatocarcinogenesis in female Sprague-Dawley rats. *Cancer Research* 40:3680–3685.
- Yahia, D., M.A. El-Nasser, M. Abdel-Latif, C. Tsukuba, M. Yoshida, I. Sato, and S. Tsuda. 2010. Effects of perfluorooctanoic acid (PFOA) exposure to pregnant mice on reproduction. *The Journal of Toxicological Sciences* 35:527–533.
- Yan, S., H. Zhang, F. Zheng, N. Sheng, X. Guo, and J. Dai. 2015. Perfluorooctanoic acid exposure for 28 days affects glucose homeostasis and induces insulin hypersensitivity in mice. *Scientific reports* 12(5):11029.
- Yang, Q., Y. Xie, and W. Depierre. 2000. Effects of peroxisome proliferators in the thymus and spleen of mice. *Clinical & Experimental Immunology* 122:219–226.
- Yang, Q., Y. Xie, A.M. Ericksson, B.D. Nelson, and J.W. DePierre. 2001. Further evidence for the involvement of inhibition of cell proliferation and development in thymic and splenic atrophy induced by the peroxisome proliferator perfluorooctanoic acid in mice. *Biochemical Pharmacology* 62:1133–1140.
- Yang, Q., Y. Xie, S.H.E. Alexson, B.D. Nelson, and J.W. DePierre. 2002a. Involvement of the peroxisome proliferator-activated receptor alpha in the immunomodulation caused by peroxisome proliferators in mice. *Biochemical Pharmacology* 63:1893–1900.
- Yang, Q., M. Abedi-Valugerdi, Y. Xie, X. Zhao, G. Molle, B.D. Nelson, and J.W. DePierre. 2002b. Potent suppression of the adaptive immune response in mice upon dietary exposure to the potent peroxisome proliferator, perfluorooctanoic acid. *International Immunopharmacology* 2:389–397.
- Yang, C., Y.S. Tan, J.R. Harkema, and S.Z. Haslam. 2009. Differential effects of peripubertal exposure to perfluorooctanoic acid on mammary gland development in C57Bl/6 and Balb/c mouse strains. *Reproductive Toxicology* 27:299–306.
- Yang, C.-H., K.P. Glover, and X. Han. 2009. Organic anion transporting polypeptide (Oatp)1a1-mediated perfluorooctanoate transport and evidence for a renal reabsorption mechanism of Oatp1a1 in renal elimination of perfluorocarboxylates in rats. *Toxicology Letters* 190:163–171.
- Yang, C.-H., K.P. Glover, and X. Han. 2010. Characterization of cellular uptake of perfluorooctanoate via organic-anion transporting polypeptide 1A2, organic anion transporter 4, and urate transporter 1 for their potential roles in mediating human renal reabsorption of perfluorocarboxylates. *Toxicological Sciences* 117:294–302.
- Yeung, L.W.Y., K.S. Guruge, S. Taniyasu, N. Yamashita, P.W. Angus, and C.B. Herath. 2013. Profiles of perfluoroalkyl substances in the liver and serum of patients with liver cancer and cirrhosis in Australia. *Ecotoxicology & Environmental Safety* 96:139–146.

- Ylinen, M., H. Hanhijarvi, I. Jaakonaho, and P. Peura. 1989. Stimulation by estradiol of the urinary excretion of perfluorooctanoic acid in the male rat. *Pharmacological & Toxicological Methods* 65:274–277.
- Ylinen, M., A. Kojo, H. Hanhijarvi, and P. Peura. 1990. Disposition of perfluorooctanoic acid in single and subchronic administration. *Bulletin of Environmental Contamination and Toxicology* 44:46–53.
- York, R.G., G.L. Kennedy, G.W. Olsen, and J.L. Butenhoff. 2010. Male reproductive system parameters in a two-generation reproduction study of ammonium perfluorooctanoate in rats and human relevance. *Toxicology* 271:64–72.
- Yoshikane, M., Y. Shibata, and N. Shimizu. 2010. *Branched Isomer Profiles of Perfluoroalkyl Carboxylates in Japanese Environment*. Poster 63. PFAA Days III: Recent advances in perfluoroalkyl acid (PFAA) research. U.S. Environmental Protection Agency, Office of Research and Development.
- Yu, N., X. Wang, B. Zhang, J. Yang, J. Li, W. Shi, S. Wei, and Y. Yu. 2015. Distribution of perfluorooctane sulfonate isomers and predicted risk of thyroid hormonal perturbation in drinking water. *Water Research* 76:171–180.
- Zaïr, Z.M., J.J. Eloranta, B. Stieger, and G.A. Kullak-Ublick. 2008. Pharmacogenetics of OATP (SLC21/SLCO), OAT and OCT (SLC22) and PRPT (SLC15) transporters in the intestine, liver, and kidney. *Pharmacogenomics* 9:597–624.
- Zeng, H.-C., Q.-Z. He, Y.-Y. Li, C.-Q. Wu, Y.-M. Wu, and S.-Q. Xu. 2014. Prenatal exposure to PFOS caused mitochondria-mediated apoptosis in heart of weaned rat. *Environmental Toxicology* 30:1082–1090.
- Zhang, L., X.-M. Ren, and L.-H. Guo. 2013. Structure-based investigation on the interaction of perfluorinated compounds with human liver fatty acid binding protein. *Environmental Science & Technology* 47:11293–11301.
- Zhang, T., H. Sun, Y. Lin, Y. Qin, X. Geng, and L. Kannan. 2013. Distribution of poly- and perfluoroalkyl substances in matched samples from pregnant women and carbon chain length related maternal transfer. *Environmental Science & Technology* 47:7974–7981.
- Zhang, Y., S. Beesoon, L. Zhu, and J.W. Martin. 2013. Biomonitoring of perfluoroalkyl acids in human urine and estimates of biological half-life. *Environmental Science & Technology* 47(18):10619–10627.
- Zhang, L., X.-M. Ren, B. Wan, and L.-H. Guo. 2014. Structure-dependent binding and activation of perfluorinated compounds on human peroxisome proliferator-activated receptor γ . *Toxicology and Applied Pharmacology* 279:275–283.
- Zhang, T., H. Sun, X. Qin, Z. Gan, and K. Kannan. 2014. PFOS and PFOA in paired urine and blood from general adults and pregnant women. *Environmental Science & Pollution Research* 22(7):5572–5579.

- Zhang, W., F. Wang, P. Xu, C. Miao, X. Zeng, X. Cui, C. Lu, H. Xie, H. Yin, F. Chen, and J. Ma. 2014. Perfluorooctanoic acid stimulates breast cancer cells invasion and up-regulates matrix metalloproteinase-2/-9 expression mediated by activating NF- κ B. *Toxicology Letters* 229(1):118–125.
- Zhang, C., R. Sundaram, J. Maisog, A.M. Calafat, D. Boyd Barr, and G.M. Buck Louis. 2015. A prospective study of prepregnancy serum concentrations of perfluorochemicals and the risk of gestational diabetes. *Fertility Sterility* 103:184–189.
- Zhao, G., J. Wang, S. Chen, Y. Zhao, F. Gu, A. Xu, and L. Wu. 2010. Mutagenicity of PFOA in mammalian cells: role of mitochondrial-dependent reactive oxygen species. *Environmental Science & Technology* 45(4):1638–1644.
- Zhao, Y., Y.S. Tan, S.Z. Haslam, and C. Yang. 2010. Perfluorooctanoic acid effects on steroid hormones and growth factor levels mediate stimulation of peripubertal mammary gland development in C57BL/6 mice. *Toxicological Sciences* 33(4):563–576.
- Zhao, B., L. Li, J. Liu, H. Li, C. Zhang, P. Han, Y. Zhang, X. Yuan, R.S. Ge, and Y. Chu. 2014. Exposure to perfluorooctane sulfonate in utero reduces testosterone production in rat fetal Leydig cells. *PLOS ONE* 9:e78888.

Appendix A: Literature Search Strategy Developing the Search

The literature search strategy was planned with input from EPA library services staff. Chemical Abstracts Service (CAS) numbers served as the basis for identification of relevant search terms. Trial searches were conducted, and results were evaluated to refine the search strategy (e.g., to prevent retrieval of citations unrelated to health and occurrence). The search string was refined to improve the relevancy of the results. All searches were conducted in the PubMed database, which contains peer-reviewed journal abstracts and articles on various biological, medical, public health, and chemical topics. The first search string (as well as future iterations) is presented below.

Every 2 weeks, a search was run in PubMed and a bibliography of the search results was compiled.

In 2012, the State of New Jersey Department of Environmental Protection (NJDEP) initiated a monthly search in PubMed for emerging literature on perfluorinated chemicals, primarily from the carboxylic acid and sulfonate families. These searches were provided to the EPA on a monthly basis. There was a high degree of overlap with the results from the EPA search, thus increasing the confidence in the search strategy.

In 2013, the EPA search strategy was expanded to cover other members of the perfluorocarboxylic acids (C-4 to C-12) and sulfonate families (C-4, C-6, C-8). The search string was altered in June of 2013 to rely more on the search features offered by PubMed.

A change in the PubMed database structure in 2015 required additional modifications to the search strategy.

The NJDEP search terms did not change from 2012 to 2015. All search iterations are noted below. However, the reports shared with EPA were streamlined to remove information on analytical methods and other nonhealth related citations that were not consistent with the criteria presented previously in the background section of this document.

Search Strategy Examples: (Arranged from most recent to oldest).

2015

Search: perfluorooctanoate OR “perfluorooctanoic acid” OR “perfluorooctanoic acid” OR pfoa OR “perfluorinated chemicals” OR “perfluorinated compounds” OR “perfluorinated homologue groups” OR “perfluorinated contaminants” OR “perfluorinated surfactants” OR perfluoroalkyl acids OR “perfluorinated alkylated substances” OR “perfluoroalkylated substances” OR pfba OR “perfluorobutanoic acid” OR perfluorochemicals OR “telomer alcohol” OR “telomer alcohols” OR “fluorotelomer alcohols” OR “polyfluoroalkyl compounds” OR “perfluorooctane sulfonate” OR pfos OR “perfluorooctanesulfonic acid” OR “perfluorooctane sulfonic acid” OR “perfluorooctane sulphonate” OR perfluorooctane sulfonate OR “perfluorooctanyl sulfonate” OR “Heptadecafluorooctane-1-sulphonic” OR “Heptadecafluoro-1-octanesulfonic acid” OR perfluorononanoate OR pfhxa OR “perfluorohexanoic acid” OR “fluorinated surfactants”

Filters: English.
Frequency: Every 2 weeks

September 2013

Search: perfluorooctanoate OR “perfluorooctanoic acid” OR “perfluorooctanoic acid” OR pfoa OR “perfluorinated chemicals” OR “perfluorinated compounds” OR “perfluorinated homologue groups” OR “perfluorinated contaminants” OR “perfluorinated surfactants” OR perfluoroalkyl acids OR “perfluorinated alkylated substances” OR “perfluoroalkylated substances” OR pfba OR “perfluorobutanoic acid” OR perfluorochemicals OR “telomer alcohol” OR “telomer alcohols” OR “fluorotelomer alcohols” OR “polyfluoroalkyl compounds” OR “perfluorooctane sulfonate” OR pfos OR “perfluorooctanesulfonic acid” OR “perfluorooctane sulfonic acid” OR “perfluorooctane sulphonate” OR perfluorooctane sulfonate OR “perfluorooctanyl sulfonate” OR “Heptadecafluorooctane-1-sulphonic acid” OR “Heptadecafluoro-1-octanesulfonic acid” OR perfluorononanoate OR pfhxa OR “perfluorohexanoic acid” OR “fluorinated surfactants”

Filters: English.
Frequency: Every 2 weeks

June 2013

Search: (PFOA[tw] OR perfluorooctanoic acid[tw] OR 335-67-1[tw] OR PFBA[tw] OR perfluorobutanoate[tw] OR 3794-64-7[tw] OR PFDA[tw] OR perfluorodecanoic acid[tw] OR 335-76-2[tw] OR PFHpA[tw] OR perfluoroheptanoic acid[tw] OR 375-85-9[tw] OR PFHxA[tw] OR perfluorohexanoic acid[tw] OR 307-24-4[tw] OR PFNA[tw] OR perfluorononanoic acid[tw] OR 375-95-1[tw] OR PFpTA[tw] OR perfluoropentanoic acid[tw] OR 2706-90-3[tw] OR PFPA[tw] OR pentafluoropropionic acid[tw] OR 422-64-0[tw]) AND (human* [tw] OR mammal*[tw]) NOT (environment* OR ecolog*)

Filters: English.
Frequency: Every 2 weeks

February, 2013

Search: perfluorooctanoate OR “perfluorooctanoic acid” OR “perfluorooctanoic acid” OR pfoa OR “perfluorinated chemicals” OR “perfluorinated compounds” OR “perfluorinated homologue groups” OR “perfluorinated contaminants” OR “perfluorinated surfactants” OR perfluoroalkyl acids OR “perfluorinated alkylated substances” OR “perfluoroalkylated substances” OR pfba OR “perfluorobutanoic acid” OR perfluorochemicals OR “telomer alcohol” OR “telomer alcohols” OR “fluorotelomer alcohols” OR “polyfluoroalkyl compounds” OR “perfluorooctane sulfonate” OR pfos OR “perfluorooctanesulfonic acid” OR “perfluorooctane sulfonic acid” OR “perfluorooctane sulphonate” OR perfluorooctane sulfonate OR “perfluorooctanyl sulfonate” OR “Heptadecafluorooctane-1-sulphonic acid” OR “Heptadecafluoro-1-octanesulfonic acid” OR perfluorononanoate OR pfhxa OR “perfluorohexanoic acid” OR “fluorinated surfactants”

Filters: English.
Frequency: Every 2 weeks

June 2011

Search (perfluorooctanoate OR “perfluorooctanoic acid” OR “perfluorooctanoic acid” OR pfoa OR “perfluorinated chemicals” OR “perfluorinated compounds” OR “perfluorinated homologue groups” OR “perfluorinated contaminants” OR “perfluorinated surfactants” OR perfluoroalkylacids OR “perfluorinated alkylated substances” OR “perfluoroalkylated substances” OR pfba OR “perfluorobutanoic acid” OR perfluorochemicals OR “telomer alcohol” OR “telomer alcohols” OR “fluorotelomer alcohols” OR “polyfluoroalkyl compounds” OR “perfluorooctane sulfonate” OR pfos OR “perfluorooctanesulfonic acid” OR “perfluorooctane sulfonic acid” OR “perfluorooctane sulphonate” OR perfluorooctanesulfonate OR “perfluorooctanyl sulfonate” OR “Heptadecafluorooctane-1-sulphonic acid” OR “Heptadecafluoro-1-octanesulfonic acid” OR perfluorononanoate OR pfhxa OR “perfluorohexanoic acid” OR “fluorinated surfactants” OR 335-67-1 [rn])

Limits: Publication Date—Dates will change for each search, English Language only

June 2009

Search (perfluorooctanoate OR “perfluorooctanoic acid” OR “perfluorooctanoic acid” OR pfoa OR “perfluorinated chemicals” OR “perfluorinated compounds” OR “perfluorinated homologue groups” OR “perfluorinated contaminants” OR “perfluorinated surfactants” OR perfluoroalkylacids OR “perfluorinated alkylated substances” OR “perfluoroalkylated substances” OR pfba OR “perfluorobutanoic acid” OR perfluorochemicals OR “telomer alcohol” OR “telomer alcohols” OR “fluorotelomer alcohols” OR “polyfluoroalkyl compounds” OR “perfluorooctane sulfonate” OR pfos OR “perfluorooctanesulfonic acid” OR “perfluorooctane sulfonic acid” OR “perfluorooctane sulphonate” OR perfluorooctanesulfonate OR perfluorononanoate OR pfhxa OR “perfluorohexanoic acid” OR “fluorinated surfactants” OR 335-67-1 [rn] OR 1763-23-1 [rn])

Limits: Entrez Date from 2009/04/07 to 2009/04/12

New Jersey Search Terms

Search: perfluorinated OR perfluorooctanoate OR perfluorononanoate OR perfluorooctanesulfonate OR perfluorooctanesulphonate OR perfluoroalkylated OR perfluoroalkyl OR polyfluoroalkyl OR polyfluorinated OR PFBA OR PFBS OR PFDA OR PFHA OR PFHPA OR PFHXA OR PFHXS OR PFNA OR PFOA OR PFOAs OR PFOS OR PFUNDA OR “perfluorooctanoic acid” OR “perfluoro octanoic acid” OR “perfluorooctane sulfonate” OR “perfluorooctane sulfonic acid” OR “perfluorooctanesulfonic acid” OR “perfluorooctane sulphonate” OR “perfluorooctanyl sulfonate” OR “perfluorobutanoic acid” OR “perfluoroalkyl acids” OR “perfluorononanoic acid” OR “perfluorohexanoic acid” OR “perfluorohexane sulfonate” OR “perfluorohexane sulphonate” OR perfluorobutanoate OR “perfluoro butanoate” OR perfluorohexanoate OR “perfluoro hexanoate”

Filters: 1

Appendix B: Studies Evaluated Since August 2014

The tables that follow identify the papers that were retrieved and reviewed for inclusion following the August 2014 peer review for the draft PFOS Health Effects Support Document. The papers listed include those recommended by the peer reviewers or public commenters, as well as those identified from the literature searches between the completion of the peer review draft and December 2015. The review of papers recommended by the commenters and their potential impact on the updates to the draft assessments was facilitated by publications such as the critical review of the recent literature by Post et al. (2012). Post et al. (2012) provides an in-depth analysis of the available health effects literature for PFOA. Papers included in the final HESD are noted and reasons provided for those that were not included in the final document.

The tables for document retrieval and review are followed by updated versions of the summaries of the epidemiology summary tables from the peer reviewed draft as recommended by the peer reviewers. They are a useful tool to facilitate a high level comparison of the study outcomes for each of the epidemiological study groupings.

The criteria utilized in determining the papers that were included in the HESD after the peer review and presented in the Background were the following:

1. The study examines a toxicity endpoint or population that had not been examined by studies already present in the draft assessment.
2. Aspects of the study design, such as the size of the population exposed or quantification approach, make it superior to key studies already included in the draft document.
3. The data contribute substantially to the weight of evidence for any of the toxicity endpoints covered by the draft document.
4. There are elements of the study design that merit its inclusion in the draft assessment based on its contribution to the mode of action or the quantification approach.
5. The study elucidates the mode of action for any toxicity endpoint or toxicokinetic property associated with PFOA exposure.
6. The effects observed differ from those in other studies with comparable protocols.

Table B-1. PFOS Epi Papers—Post Peer Review (Retrieved and Reviewed)

Authors and Year	Topic—Keywords	Status/Notes
Andersen et al. 2013	Postnatal growth	Added PFOA/PFOS
Back et al. 2015	Time to pregnancy	Added PFOA
Barrett et al. 2015	Ovarian hormone	Not Added—No association observed for PFOA; PFOS was not included in the assessment
Berg et al. 2015	Thyroid	Added PFOA/PFOS
Bonefeld-Jørgenson et al. 2014	Breast cancer	Added PFOA/PFOS
Bonefeld-Jørgenson et al. 2011	Breast cancer	Added PFOA/PFOS
Brieger et al. 2011	Immune effects	Already presented in PFOS/PFOA
Buck Louis et al. 2015	Semen quality	Added PFOA/PFOS
Chang et al. 2014	Analysis of human cancer studies	Added PFOA in the cancer weight of evidence section
Chen et al. 2015	Birth weight	Added PFOS
Dankers et al. 2013	Blood-testis barrier	Reviewed,—not added; Study of an assay that used PFOA as one chemical in the test battery

Authors and Year	Topic—Keywords	Status/Notes
Darrow et al. 2013	Reproductive outcome	Added PFOA/PFOS
Darrow et al. 2014	Miscarriage	Added PFOA/PFOS
Donauer et al. 2015	Infant Neurobehavior	Not added—negative for PFOS; No statistical differences in PFOA levels during pregnancy and any neuro endpoint. Better studies.
Eriksen et al. 2013	Total cholesterol—Danish	Added PFOA/PFOS
Fitz-Simon et al. 2013	Serum lipids	Added PFOA/PFOS
Fisher et al. 2013	Plasma lipids	Added PFOA/PFOS
Fletcher et al. 2013	Cholesterol—genes	Added PFOA/PFOS
Fu et al. 2014	Serum lipids in Chinese subjects	Not added: Chinese population, dataset available on U.S. population. More branched chain isomers found among the people in China.
Geiger et al. 2014a	Lipids/children	Added PFOA/PFOS
Geiger et al. 2014b	Hypertension/children	Added PFOA/PFOS
Ghisari et al. 2014	Breast cancer—Inuit	Not added; same population as Bonefeld-Jørgensen et al. 2014; this study focuses on gene polymorphisms
Governini et al. 2015	DNA effects in sperm	Added PFOA/PFOS
Grandjean and Clapp 2015	Health Risks	Not added; the primary studies are already included in the documents.
Granum et al. 2013	Immune children	Added PFOA/PFOS
Hardell et al. 2014	Prostate cancer	Added PFOA/PFOS
Høyer et al. 2015a	Human weight	Added PFOA/PFOS
Høyer et al. 2015b	Behavior motor development	Added PFOA/PFOS
Humblet et al. 2014	Asthma	Added PFOA/PFOS
Jain 2014	NHANES	Added PFOA/PFOS
Innes et al. 2014	Colorectal cancer	Added PFOA/PFOS
Joensen et al. 2013	Sperm	Added PFOA/PFOS
Kerger et al. 2011	Cholesterol C8	Added; demographics for cholesterol and PFOS in summary section of epi studies
Kjeldsen and Bonefeld-Jørgensen 2013	Sex hormones	Covered multiple PFAS <i>in vitro</i> no impact on weight of evidence
Kristensen et al. 2013	Prenatal female repro	Added PFOA/PFOS
Liew et al. 2014	Cerebral palsy children	Added PFOA/PFOS
Looker et al. 2014	Immune	Added PFOA/PFOS
López-Doval et al. 2014	Male repro	Added PFOS
Maisonet et al. 2015	Gestational diabetes	Added PFOA/PFOS
Maisonet et al. 2012	Birth weight	Added PFOA/PFOS
Mørck et al. 2015	PFAS levels in children	Not added; No significant impact
Okada et al. 2014	Allergy children	Added PFOS
Osuna et al. 2014	Antibodies PFOS PFOA	Not added; focus more on methylHg and PCB than PFAS; only n = 38 as preliminary study
Roth and Wilks 2014	Neurodevelopmental	. Not added; no significant impact
Shrestha et al. 2015	Thyroid	Added PFOA/PFOS

Authors and Year	Topic—Keywords	Status/Notes
Starling et al. 2014	Plasma lipids	Added PFOA/PFOS
Steenland et al. 2015	Workers	Added PFOA
Stein et al. 2009	Pregnancy	Added PFOA
Taylor et al. 2014	Menopause	Added PFOA/PFOS
Vanden Heuvel 2013	Serum lipids	Not added; is a rebuttal of Fletcher et al. 2013 conclusions. No significant impact
Vassiliadou et al. 2010	PFOS in cancer vs non-cancer patients	Added PFOA/PFOS
Vélez et al. 2015	Fertility	Added PFOA/PFOS
Verner et al. 2015	Fetal growth GFR	Added PFOA/PFOS
Verner and Longnecker 2015	Menstruation/excretion	Added PFOS
Vested et al. 2013	Semen quality and hormones	Added PFOS/PFOS
Vesterinen et al. 2014	Fetal Growth GFR	Added PFOA/PFOS
Wang et al. 2013	Thyroid	Added PFOA/PFOS
Watkins et al. 2013	Kidney function	Added PFOA/PFOS
Webster et al. 2014	Maternal thyroid	Added PFOA/PFOS
Webster et al. 2015	Thyroid—iodine statue	Added PFOS
Wen et al. 2013	Thyroid	Added PFOA/PFOS
Yeung et al. 2013	Liver cancer	Added PFOA/PFOS
Zhang et al. 2015	Gestational diabetes	Added PFOA/PFOS

Table B-2. PFOA Post Peer Review Animal Toxicity Studies

Authors and Year	Topic	Action Notes
Bjork et al. 2011	Nuclear receptor activation	In vitro, mechanistic findings comparable to studies already included
Corsini et al. 2014	Immune data review	Not added; no significant impact
Corsini et al. 2012	Immune in vitro data review	Not added; no significant impact
Dewitt et al. 2015	Immunotoxicity	Added PFOA
Fenton 2015	Repro editorial	Not added
Filgo et al. 2015	Liver tumors in females developmentally exposed	Added PFOA
Hall et al. 2012	PPAR α and cancer	Cited in synthesis. Paper on adversity of liver hypertrophy PFOA/ PFOS
Kousta et al. 2014	Fetal growth (animal studies) navigation guide	Added PFOA
Liu et al. 2015	Testes	Added PFOA
Long et al. 2013	Neurotoxicity adult PFOS	Added PFOS
Lu et al. 2015	Testes	Added PFOA
Ngo et al. 2014	Tumors mice Min/+ PFOS	Added PFOS
Post et al. 2012	Review paper	Not added. Key studies included in the document; no significant impact
Quist et al. 2015	Liver histopathology/high fat diet post weaning exposure	Added PFOA
Rigden et al. 2015	Acute liver effects	Added PFOA
Shabalina et al. 2015	Brown fat uncoupling protein 1	Not added. Mechanistic; no significant impact

Authors and Year	Topic	Action Notes
Sheng et al. 2016	Binding to liver fatty acid binding protein	Not added; no significant impact, topic covered by other papers
Tan et al. 2012	Gene activation	Added PFOA/PFOS
Tan et al. 2013	Gene activation dietary fat	Added PFOA
Tucker et al. 2015	Mammary gland	Added PFOA
Wallace et al. 2013	Mitochondrial respiration	Not added. No significant impact, topic covered by other papers
Wan et al. 2014b	Glucose metabolism	Added PFOS
Wan et al. 2012	Hepatic steatosis	Added PFOS
Wan et al. 2014a	Sertoli cells	Added PFOS
F. Wang et al. 2015	MiRNA liver PFOS early life	Not added; no significant impact
S. Wang et al. 2014	Lysine decarboxylase	Added PFOA/PFOS
L. Wang et al. 2014	Inhibition of LDL	Added PFOS
Y. Wang et al. 2015	Special learning and memory	Added PFOS
Yan et al. 2015	Glucose homeostasis	Not added. Dose-response in Wan (2014b) presented (more robust). Single dose for whole animal
Yu et al. 2015	Thyroid PFOS isomers	Added PFOS
Zeng et al. 2014	Mitochondrial mediated apoptosis of the heart	Added PFOS
L. Zhang et al. 2013	Fatty acid binding protein	Added PFOA/PFOS
Y. Zhang et al. 2013	Biological half-life	Added PFOA/PFOS
W. Zhang et al. 2014	Breast cancer cell invasion—mechanistic	Not added; <i>in vitro</i> , no significant impact
Zhao et al. 2014	Testosterone reduction in Leydig cells PFOS	Added PFOS

Table B-3. Toxicokinetics: Post Peer Review

Authors and Year	Topic	Action Notes
D'Alessandro et al. 2013	Serum albumin	Added PFOS
Augustine et al. 2005	Transporter expression testes	Not added background paper on testes transporters –no relationship to PFOA PFOA or any PFAS
Beesoon et al. 2011	Isomer profile	Added PFOA
Beesoon and Martin 2015	Albumin binding	Added PFOA
Cui et al. 2010	Excretion subchronic	Added PFOA/PFOS
Fàbrega et al. 2014	PK model	Added PFOA/PFOS
Kerstner-Wood et al. 2003	Plasma protein binding	Added—PFOA/PFOS
Klaassen and Aleksunes 2010	Transporter paper—Provided diagram of kidney transporters	Added PFOA
Loccisano et al. 2013	PK model—Human	Added PFOA/PFOS
Mondal et al. 2014	Breast milk	Added PFOS/PFOA
Ospinal-Jimenez and Pozzo 2012	Protein denaturation	Added PFOS
Pérez et al. 2013	Human tissue levels	New PFOA/PFOS
Ren et al. 2015	Thyroid hormone receptor binding (<i>in vitro</i>)	Added PFOA/PFOS
Rigden et al. 2015	Liver and excretion	Added PFOA
Shabalina et al. 2015	Brown fat	Not added; No information on MOA for body weight effects in the animal or human studies
Slitt et al. 2007	Transporter expression PFOA	Not added. Reported on transporters during extrahepatic cholestasis. No data on PFOA and PFOS. No significant impact.
Tucker et al. 2015	Menstruation-excretory route	Added PFOA
Verner and Longnecker 2015	Excretion PFOS	Added PFOS
Wambaugh et al. 2013	PK model	Added PFOA/PFOS
Wong et al. 2014	Menstrual blood as excretory route	Added PFOA/PFOS
T. Zhang et al. 2014	Excretion general population and pregnancy	Added PFOA/PFOS
L. Zhang et al. 2014	PPAR gamma	Added PFOS
Y. Zhang et al. 2013	Excretion, half-life	Added PFOA/PFOS
T. Zhang et al. 2013	Maternal transfer	Added PFOA/PFOS

Tables B-4 through B-8 provide updated versions of the epidemiology summary tables from the peer-reviewed draft, as recommended by the reviewers. They are a useful tool to facilitate a high-level comparison of the study outcomes for each of the epidemiology study groupings.

Table B-4. Association between Serum PFOA and Serum Lipids and Uric Acid

Reference	Study Type	n	Mean Serum PFOA	TC	VLDL	LDL	HDL	Non-HDL	TG	UA
Occupational Populations										
Olsen et al. 2000	Cross-sectional	111 (1993) 80 (1995) 74 (1997)	0–80 µg/mL 0–114 µg/mL 0.1–81 µg/mL	↔ ↔ ↔	NM	↔ ↔ ↔	↔ ↔ ↔	NM	↔ ↔ ↔	NM
Olsen et al. 2001b, 2003	Cross-sectional	206 (Antwerp) 215 (Decatur)	1.03 µg/mL 1.90 µg/mL	↑	NM	NM	↔	NM	↑	NM
Olsen et al. 2001c, 2003	Longitudinal; ~5 years	175 (Decatur and Antwerp combined for analysis)	1.36–1.41 µg/mL (1995 baseline) 1.49–1.77 µg/mL (2000 follow-up)	↑	NM	NM	↔	NM	↑	NM
Sakr et al. 2007a	Cross-sectional	1,025	0.428 µg/mL	↑	↑	↑	↔	NM	↔	↑
Sakr et al. 2007b	Longitudinal	454 (23-yr follow-up)	1.04 µg/mL (first) 1.16 µg/mL (last)	↑	NM	↔	↔	NM	↔	NM
Olsen and Zobel 2007	Cross-sectional	506 (Antwerp, Cottage Grove, Decatur combined)	2.21 µg/mL	↔	NM	↔	↓	NM	↑	NM
Costa et al. 2009	Cross-sectional	34 workers 107 controls	4.02 µg/mL	↑	NM	NM	↔	NM	↔	↑
General Populations										
Emmett et al. 2006	Cross-sectional	371	0.354 µg/mL	↔	NM	NM	NM	NM	NM	NM
Steenland et al. 2009	Cross-sectional (C8)	46,294	0.08 µg/mL	↑	NM	↑	↔	↑	↑	NM
Steenland et al. 2010	Cross-sectional (C8)	53,458	0.086 µg/mL	NM	NM	NM	NM	NM	NM	↑

Reference	Study Type	n	Mean Serum PFOA	TC	VLDL	LDL	HDL	Non-HDL	TG	UA
Winqvist and Steenland 2014a	Cross-sectional (C8)	32,254	0.0261 µg/mL	↑	NM	NM	NM	NM	NM	NM
Frisbee et al. 2010	Cross-sectional (C8, children and adolescents)	6,536 children 5,934 adolescents	0.0777 µg/mL 0.0618 µg/mL	↑	NM	↑	↔	NM	↑	NM
Fitz-Simon et al. 2013	Longitudinal; 4.4 years (C8)	521	0.140 µg/mL (baseline) 0.068 µg/mL (follow-up)	↔	NM	↔	↔	NM	↔	NM
Nelson et al. 2010	Cross-sectional (NHANES)	1,445	0.0046 µg/mL	↑	NM	↔	↔	↑	NM	NM
Eriksen et al. 2013	Cross-sectional	753	0.0071 µg/mL	↑	NM	NM	NM	NM	NM	NM
Starling et al. 2014	Cross-sectional (maternal at 14–26 weeks gestation)	891	0.00225 µg/mL	↔	NM	↔	↑	NM	↔	NM
Fisher et al. 2013	Cross-sectional	2,700	0.0025 µg/mL	↔	NM	↔	↔	NM	NM	NM

Notes: ↑ = positive association; ↓ = negative association; ↔ = no association; TC = total cholesterol; VLDL= very low density lipoprotein; LDL= low-density lipoprotein; non-HDL= TC(VLDL,IDL, LDL)-HDL; HDL= high-density lipoprotein; TG = triglycerides; UA = uric acid; NM = not measured

Table B-5. Association of Serum PFOA and Biochemical and Hematological Measures

Reference	Study Type	n	Mean Serum PFOA	Liver enzymes	Bilirubin	Renal Enzymes/Function	Glucose	Hematology
Occupational Populations								
Olsen et al. 2000	Cross-sectional	111 (1993) 80 (1995) 74 (1997)	0–80 µg/mL 0–114 µg/mL 0.1–81 µg/mL	↔ ↔ ↔	↔ ↔ ↔	↔ ↔ ↔	↔ ↔ ↔	↔ ↔ ↔
Olsen et al. 2001b, 2003	Cross-sectional	206 (Antwerp) 215 (Decatur)	1.03 µg/mL 1.90 µg/mL	↔ ↔	↔ ↔	↔ ↔	↔ ↔	↔ ↔
Olsen et al. 2001c, 2003	Longitudinal; ~5 years	175 (Decatur and Antwerp combined for analysis)	1.36–1.41 µg/mL (1995 baseline) 1.49–1.77 µg/mL (2000 follow-up)	↔ ↔	↔ ↔	↔ ↔	↔ ↔	↔ ↔
Sakr et al. 2007a	Cross-sectional	1025	0.428 µg/mL	↑ (GGT only)	↔	NM	↔	↔
Sakr et al. 2007b	Longitudinal	454	1.04 µg/mL (first) 1.16 µg/mL (last)	↑ (AST only)	↓	NM	NM	NM
Olsen and Zobel 2007	Cross-sectional	506 (Antwerp, Cottage Grove, Decatur combined)	2.21 µg/mL	↑ (ALP, ALT, GGT Decatur only)	↓	NM	NM	NM
Costa et al. 2009	Cross-sectional	56 workers	4.02 µg/mL	↑ (GGT, ALP, ALT)	↓	↔	↔	↔
General Populations								
Emmett et al. 2006	Cross-sectional	371	0.354 µg/mL	↔	NM	↔	NM	↔
Lin et al. 2010	Cross-sectional (NHANES)	1076 men 1140 women	0.00505 µg/mL 0.00406 µg/mL	↑ (ALT, GGT)	↔	NM	NM	NM
Gallo et al. 2012	Cross-sectional (C8)	47,092	0.028 µg/mL	↑ (ALT)	↔	NM	NM	NM
Shankar et al. 2011	Cross-sectional (NHANES)	4587	0.0059 µg/mL	NM	NM	↑ (chronic kidney disease)	NM	NM
Watkins et al. 2013	Cross-sectional (C8)	9,660 (children)	0.0283 µg/mL	NM	NM	↑ (decreased eGFR)	NM	NM

Notes: ↑ = positive association; ↓ = negative association; ↔ = no association; ALP = alkaline phosphatase; eGFR = estimated glomerular filtration rate; GGT = gamma-glutamyl transpeptidase; AST = aspartate aminotransferase; ALT = alanine transaminase; NM = not measured

Table B-6. Association between PFOA level and prevalence of thyroid disease and thyroid hormone levels

Study	Study Type	Population (n)	Mean Serum PFOA (µg/mL)	Thyroid Disease	TSH	T3	T4
Occupational Populations							
Olsen et al. 1998	Cross-sectional	111 and 80 Adult workers	10–30 >30	NM NM	↑ ↔	NM	NM
Olsen et al. 2001b, 2003	Cross-sectional	Adult workers 215 (Decatur) 206 (Antwerp)	1.9 1.03	NM	↔	↔	↔
Sakr et al. 2007a	Cross-sectional	1,025 Adult workers	0.428	NM	↔	↔	↔
Costa et al. 2009	Cross-sectional	56 Adult workers	4.02	NM	↔	↔	↔
Olsen and Zobel 2007	Cross-sectional	506 Adult workers	2.21	NM	↔	↑	↔ serum ↓ free
General Populations							
Emmett et al. 2006	Cross-sectional	40 (thyroid disease) 331 (no thyroid disease)	0.387 0.451	↔	NM	NM	NM
Pirali et al. 2009	Cross-sectional	28 Adults	2.0 ng/g thyroid tissue	↔	NM	NM	NM
Bloom et al. 2010	Cross-sectional	31 Adults	0.00133	NM	↔	NM	↔
Shrestha et al. 2015	Cross-sectional	51 men 36 women	0.0104	↔	↔	↑	↑
Winqvist and Steenland 2014b	Cross-sectional	32,254 (C8)	0.0261	↔ (men) ↑ (women)	NM	NM	NM
Lopez-Espinosa et al. 2012	Cross-sectional	10,725 children (C8)	0.0293	↑	↔	NM	↔
Melzer et al. 2010	Cross-sectional	3,966 Adults (NHANES)	0.025 (men) 0.019 (women)	↔ (men) ↑ (women)	NM	NM	NM
Wen et al. 2013	Cross-sectional	1,181 (NHANES)	0.00415	NM	↔	↔	↔
de Cock et al. 2014	Cross-sectional	83 newborns	0.000943 (cord)	NM	NM	NM	↔ boys ↑ girls
Lin et al. 2013	Cross-sectional	545	0.00267	NM	↔	NM	↔
Chan et al. 2011	Cross-sectional	271 Pregnant women	0.00135	NM	↔	NM	↔
Wang et al. 2013	Cross-sectional	903 women at gestation week 18	0.0022	NM	↔	NM	NM

Study	Study Type	Population (n)	Mean Serum PFOA (µg/mL)	Thyroid Disease	TSH	T3	T4
Berg et al. 2015	Cross-sectional	375 women at gestation week 18, day 3 and week 6 after delivery (Norwegian Mother/Child Cohort)	0.00153	NM	↔	↔	↔
Webster et al. 2014	Cross-sectional	152 women at gestation week 15–18	0.0017	NM	↔	↔	↔

Notes: ↑ = positive association; ↓ = negative association; ↔ = no association; NM = Not Measured

Table B-7. Association between Serum PFOA and Markers of Immunotoxicity

Study	Study Type	Population (n)	Mean or Median Serum PFOA (µg/mL)	Disease Prevalence	Vaccine Response
Steenland et al. 2015	Cross-sectional	Workers (6,027)	0.113	↑ ulcerative colitis ↑ rheumatoid arthritis ↓ asthma	NM
Okada et al. 2012	Prospective cohort	Maternal, third trimester (343)	0.0014	↔ up to 18 months old	NM
Fei et al. 2010b	Cross-sectional	Maternal, first trimester (1,400)	0.0056	↔ early childhood	NM
Grandjean et al. 2012	Prospective cohort	Maternal at gestation week 32 (587)	0.0032	NM	↓ (antibody titer)
Grandjean et al. 2012	Prospective cohort	Children age 5 years (587)	0.00406	NM	↓ (antibody titer)
Granum et al. 2013	Prospective cohort	Women at delivery (56)	0.0011	↔	↔
Dong et al. 2013	Cross-sectional	Children age 10–15 years (231 asthmatics and 225 controls)	0.0015 (asthmatics) 0.0010 (nonasthmatics)	↑ for asthma	NM
Humblet et al. 2014	Cross-sectional	Children age 12–19 years (1,877)	0.0043 (asthmatics) 0.0040 (nonasthmatics)	↑ for asthma	NM
Looker et al. 2014	Cross-sectional	Adults (411)	0.0337	NM	↓ (antibody titer)

Notes: ↑ = positive association; ↓ = negative association; ↔ = no association; NM = Not Measured

Table B-8. Association between Serum PFOA and Reproductive and Developmental Outcomes

Study	Study Type	n	Mean Serum PFOA	Outcome	Measures at Birth	Growth/ Development	Fecundity/ Fertility
Reproductive Outcome, Anthropometric Measures at Birth							
Fei et al. 2007, 2008a, 2009, 2010a	Cross-sectional	1,400	0.0056 µg/mL	↔ (gestation length) ↓ (length of breastfeeding)	↓ (weight) ↓ (size) ↔ (Apgar score)	NM	↑ (TTP) ↑ (infertility)
Vélez et al. 2015	Cross-sectional	1,743	0.00166 µg/mL	NM	NM	NM	↑ (TTP) ↑ (infertility)
Nolan et al. 2009, 2010	Cross-sectional	1,555	0.00678 µg/mL	↔ (preterm birth, congenital anomalies, labor/delivery complications, maternal risk)	↔ (weight)	NM	NM
Stein et al. 2009	Cross-sectional (C8)	1,505	0.0488 µg/mL	↔ (miscarriage)	↔ (low weight)	NM	NM
Darrow et al. 2013, 2014	Cross-sectional (C8)	1,330 and 1,129	0.031–0.0337 µg/mL	↔ (preterm, miscarriage)	↔ (low weight, birth weight)	NM	↑ (hypertension)
Apelberg et al. 2007	Cross-sectional	293	0.0016 µg/mL (cord blood)	↔ (gestational age)	↓ (weight, head circumference, ponderal index)	NM	NM
Monroy et al. 2008	Cross-sectional	101	0.00254 µg/mL (maternal at 24-28 weeks) 0.00224 µg/mL (maternal at delivery) 0.0019 µg/mL (umbilical cord blood)	NM	↔ (weight)	NM	NM
Washino et al. 2009	Cross-sectional	428	0.0014 µg/mL	NM	↔ (weight and size)	NM	NM
Hamm et al. 2010	Cross-sectional	252	0.0021 µg/mL	↔ (gestation length)	↔ (weight)	NM	NM
Whitworth et al. 2012	Cross-sectional	849	0.0021 µg/mL	NM	↔ (birth weight)	NM	NM
Maisonet et al. 2012	Cross-sectional	395	0.0037 µg/mL	NM	↓ (birth weight)	NM	NM
Chen et al. 2012	Cross-sectional	429	0.0018 µg/mL	NM	↔ (birth weight)	NM	NM

Study	Study Type	n	Mean Serum PFOA	Outcome	Measures at Birth	Growth/ Development	Fecundity/ Fertility
Male Fertility							
Joensen et al. 2009 (PFOA/PFOS combined)	Cross-sectional	105	0.0049 µg/mL	NM	NM	NM	↓ (normal sperm) ↔ (testosterone)
Joensen et al. 2013	Cross-sectional	247	0.0035 µg/mL	NM	NM	NM	↔ (semen parameters) ↔ (testosterone, hormones)
Buck Louis et al. 2015	Cross-sectional	462	0.00429–0.00509 µg/mL	NM	NM	NM	↑ (lower % sperm with coiled tail) (total of six PFAS associated with changes in sperm quality)
Neurodevelopmental Endpoints							
Fei et al. 2008b	Cross-sectional	1,400	0.0056 µg/mL	NM	NM	↔ (motor skills and mental develop. at 6 and 18 months)	NM
Lieu et al. 2014	Cross-sectional	156 cases 550 controls	0.00456 µg/mL	NM	NM	↑ (cerebral palsy in boys)	NM
Fei and Olsen 2011	Cross-sectional	787 (behavior) 537 (coordination)	0.0057 µg/mL	NM	NM	↔ (behavior and coordination at 7 years)	NM
Høyer et al. 2015a	Cross-sectional	1,106	0.0014 µg/mL	NM	NM	↔ (motor skills) ↑ (hyperactivity)	NM
Stein et al. 2013	Cross-sectional (C8)	321	0.0351 µg/mL (child)	NM	NM	↔ (behavioural problems) ↑ (executive function; ADHD from mother, not teacher)	NM
Hoffman et al. 2010	Cross-sectional (NHANES)	571 children	0.0044 µg/mL	NM	NM	↑ (ADHD)	NM

Study	Study Type	n	Mean Serum PFOA	Outcome	Measures at Birth	Growth/ Development	Fecundity/ Fertility
Postnatal Development							
Andersen et al. 2010	Cross-sectional	1,010	0.0052 µg/mL	NM	NM	↓ (weight and BMI in boys at 5 and 12 months)	NM
Andersen et al. 2013	Cross-sectional	811 (children at age 7 years)	0.0053 µg/mL	NM	NM	↔ (height, weight, waist measurement, risk of overweight)	NM
Høyer et al. 2015b	Cross-sectional	1,022	0.001–0.0018 µg/mL	NM	NM	↔ (overweight) ↑ (waist-to-height ratio)	NM
Lopez-Espinosa et al. 2011	Cross-sectional (C8)	3,076 boys 2,931 girls	0.02–0.026 µg/mL	NM	NM	↑ (delayed puberty in girls)	NM
Christensen et al. 2011	Cross-sectional	448 girls	0.0036–0.0039 µg/mL (maternal)	NM	NM	↔ (age at menarche)	NM
Kristensen et al. 2013	Cross-sectional	343 women	0.0036 µg/mL (maternal)	NM	NM	↑ (delayed puberty)	NM
Vested et al. 2013	Cross-sectional	169 men	0.0038 µg/mL (maternal)	NM	NM	↑ (lower sperm conc and total count)	NM
Halldorsson et al. 2012	Cross-sectional	665	0.0037 µg/mL	NM	NM	↑ (overweight in females at 20 years)	NM

Notes: ↑ = positive association; ↓ = negative association; ↔ = no association; NM = Not Measured

Appendix C: Multistage Model for Leydig Cell Tumors

```

=====
Multistage Cancer Model. (Version: 1.9; Date: 05/26/2010)
Input Data File: C:/1Data/MyFiles/PFOA-PFOS/PFOA Docs/msc_Leydig_Opt.(d)
Gnuplot Plotting File: C:/1Data/MyFiles/PFOA-PFOS/PFOA Docs/msc_Leydig_Opt.plt
Thu May 09 11:59:27 2013
=====

```

BMDS_Model_Run

The form of the probability function is:

$$P[\text{response}] = \text{background} + (1-\text{background}) * [1-\text{EXP}(-\text{beta1} * \text{dose}^1 - \text{beta2} * \text{dose}^2)]$$

The parameter betas are restricted to be positive

Dependent variable = Col2
Independent variable = Col1

Total number of observations = 3
Total number of records with missing values = 0
Total number of parameters in model = 3
Total number of specified parameters = 0
Degree of polynomial = 2

Maximum number of iterations = 250
Relative Function Convergence has been set to: 1e-008
Parameter Convergence has been set to: 1e-008

Default Initial Parameter Values

Background = 0.0132945
Beta(1) = 0.0097738
Beta(2) = 0

Asymptotic Correlation Matrix of Parameter Estimates

(*** The model parameter(s) -Beta(2) have been estimated at a boundary point, or have been specified by the user, and do not appear in the correlation matrix)

	Background	Beta(1)
Background	1	-0.64
Beta(1)	-0.64	1

Parameter Estimates

Variable	Estimate	Std. Err.	95.0% Wald Confidence Interval	
			Lower Conf. Limit	Upper Conf. Limit
Background	0.00409839	*	*	*
Beta(1)	0.0116288	*	*	*
Beta(2)	0	*	*	*

* - Indicates that this value is not calculated.

Analysis of Deviance Table

Model	Log(likelihood)	# Param's	Deviance	Test d.f.	P-value
Full model	-28.6454	3			
Fitted model	-29.3468	2	1.40286	1	0.2362
Reduced model	-34.0451	1	10.7995	2	0.004518
AIC:	62.6936				

Goodness of Fit

Dose	Est. Prob.	Expected	Observed	Size	Scaled Residual
0.0000	0.0041	0.205	0.000	50	-0.454
1.3000	0.0190	0.952	2.000	50	1.084
14.2000	0.1557	7.784	7.000	50	-0.306
Chi ² = 1.48	d.f. = 1	P-value = 0.2245			

Benchmark Dose Computation

Specified effect	=	0.04
Risk Type	=	Extra risk
Confidence level	=	0.95
BMD	=	3.51044
BMDL	=	1.99346
BMDU	=	10.7788

Taken together, (1.99346, 10.7788) is a 90 % two-sided confidence interval for the BMD

Multistage Cancer Slope Factor = 0.0200656

Multistage Cancer Model with 0.95 Confidence Level

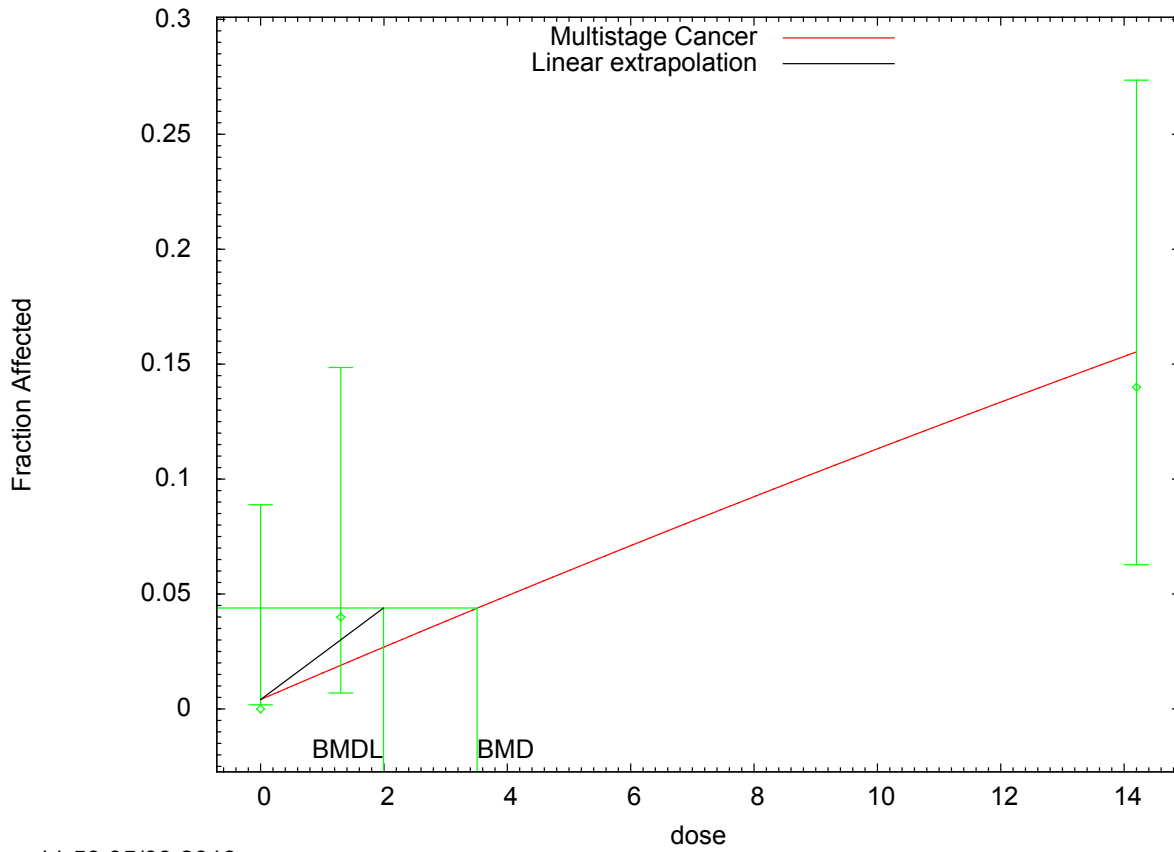

11:59 05/09 2013

```

=====
Multistage Cancer Model. (Version: 1.9; Date: 05/26/2010)
Input Data File: C:/1Data/MyFiles/PFOA-PFOS/PFOA Docs/msc_Leydig_Opt.(d)
Gnuplot Plotting File: C:/1Data/MyFiles/PFOA-PFOS/PFOA Docs/msc_Leydig_Opt.plt
                        Thu May 09 12:05:42 2013
=====

```

```

BMD5_Model_Run
~~~~~

```

The form of the probability function is:

$$P[\text{response}] = \text{background} + (1-\text{background}) * [1-\text{EXP}(-\text{beta}1 * \text{dose}^1)]$$

The parameter betas are restricted to be positive

Dependent variable = Col2
Independent variable = Col1

Total number of observations = 3
Total number of records with missing values = 0
Total number of parameters in model = 2
Total number of specified parameters = 0
Degree of polynomial = 1

Maximum number of iterations = 250
Relative Function Convergence has been set to: 1e-008
Parameter Convergence has been set to: 1e-008

Default Initial Parameter Values
 Background = 0.0132945
 Beta(1) = 0.0097738

Asymptotic Correlation Matrix of Parameter Estimates

	Background	Beta(1)
Background	1	-0.64
Beta(1)	-0.64	1

Parameter Estimates

Variable	Estimate	Std. Err.	95.0% Wald Confidence Interval	
			Lower Conf. Limit	Upper Conf. Limit
Background	0.00409839	*	*	*
Beta(1)	0.0116288	*	*	*

* - Indicates that this value is not calculated.

Analysis of Deviance Table

Model	Log(likelihood)	# Param's	Deviance	Test d.f.	P-value
Full model	-28.6454	3			
Fitted model	-29.3468	2	1.40286	1	0.2362
Reduced model	-34.0451	1	10.7995	2	0.004518
AIC:	62.6936				

Goodness of Fit

Dose	Est. Prob.	Expected	Observed	Size	Scaled Residual
0.0000	0.0041	0.205	0.000	50	-0.454
1.3000	0.0190	0.952	2.000	50	1.084
14.2000	0.1557	7.784	7.000	50	-0.306

Chi² = 1.48 d.f. = 1 P-value = 0.2245

Benchmark Dose Computation

Specified effect = 0.04
 Risk Type = Extra risk
 Confidence level = 0.95
 BMD = 3.51044
 BMDL = 1.99346
 BMDU = 8.7003

Taken together, (1.99346, 8.7003) is a 90% two-sided confidence interval for the BMD

Multistage Cancer Slope Factor = 0.0200657